

Ejercicio 11.1

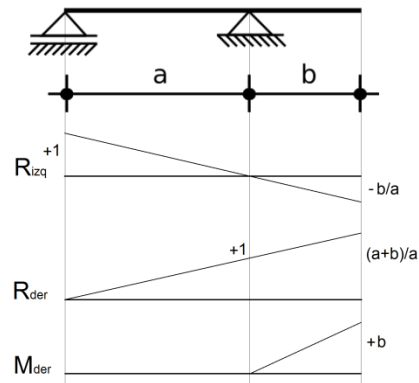

Ejercicio 11.2

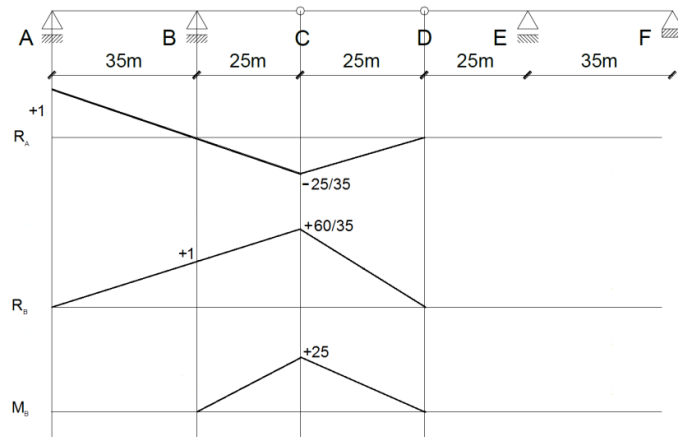

Ejercicio 11.3

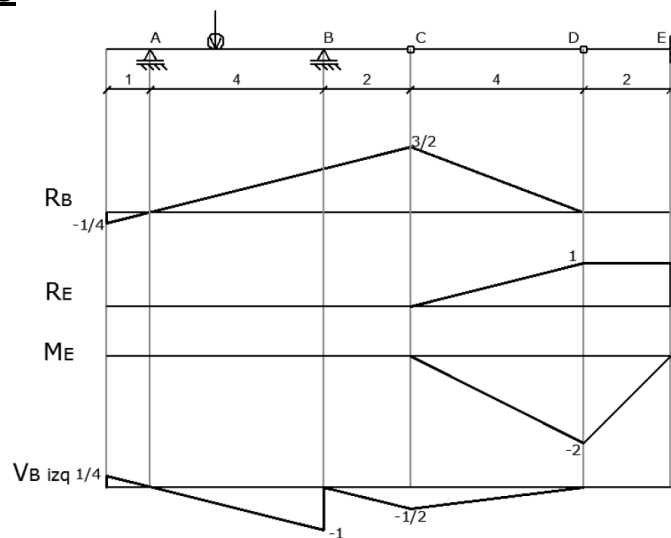

- R_B) Máximo: +15 kN, Mínimo: -0.25 kN
- R_E) Máximo: +8 kN, Mínimo: 0 kN
- M_E) Máximo: 0 kNm, Mínimo: -12 kNm
- $V_{B\ izq}$) Máximo: +0.25 kN, Mínimo: -7 kN

Ejercicio 10.4

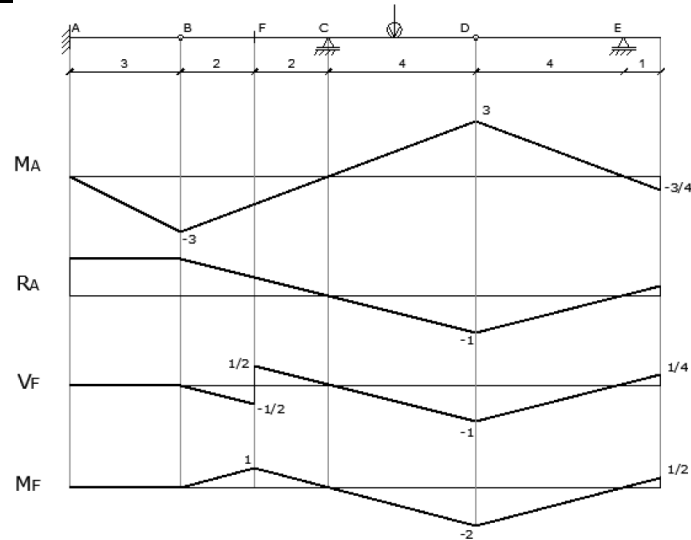

$M_{A,máx}=225 \text{ kNm}$; $M_{A,min}=-225 \text{ kNm}$
 $R_{A,máx}=90 \text{ kN}$; $R_{A,min}=-75 \text{ kN}$;
 $V_{F,máx}=30 \text{ kN}$; $V_{F,min}=-75 \text{ kN}$
 $M_{F,máx}=60 \text{ kNm}$; $M_{F,min}=-150 \text{ kNm}$

Ejercicio 10.5

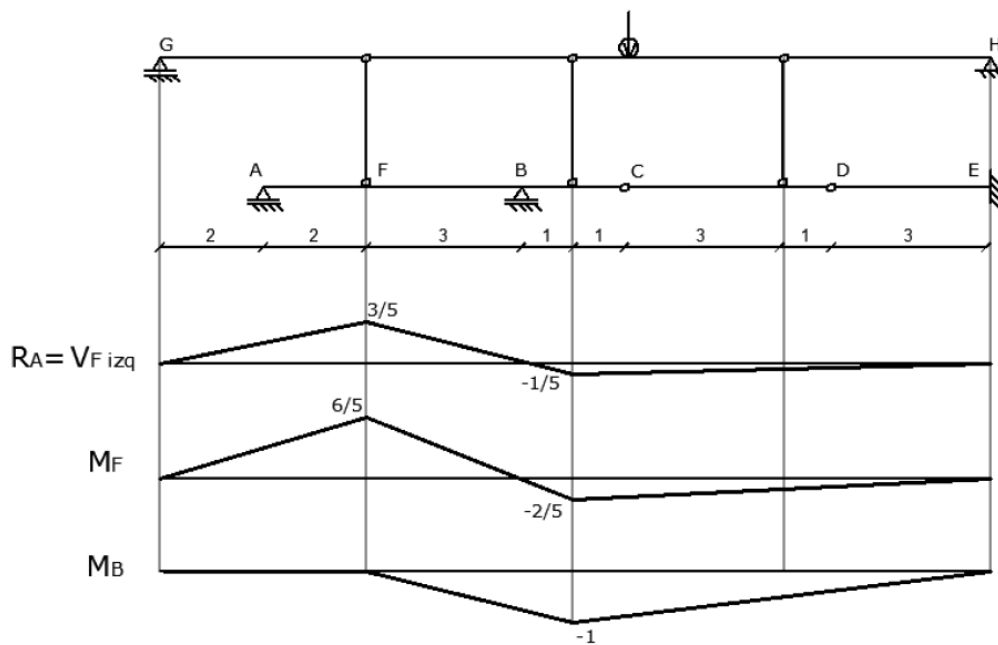

Ejercicio 10.6

