

AUTÓMATAS PROGRAMABLES

Agustín Rodríguez

Introducción al Control Industrial – Curso 2020

INSTRUCCIONES BÁSICAS

- Contactos
- Retención
- Contadores
- Temporizadores



INSTRUCCIONES BÁSICAS

- Load (LD)

- examine if closed (XIC)



- Load Bar (LDB)

- LoadNot

- examine if open (XIO)



- Out

- OutputEnergize



EJEMPLO

Circuito con relé

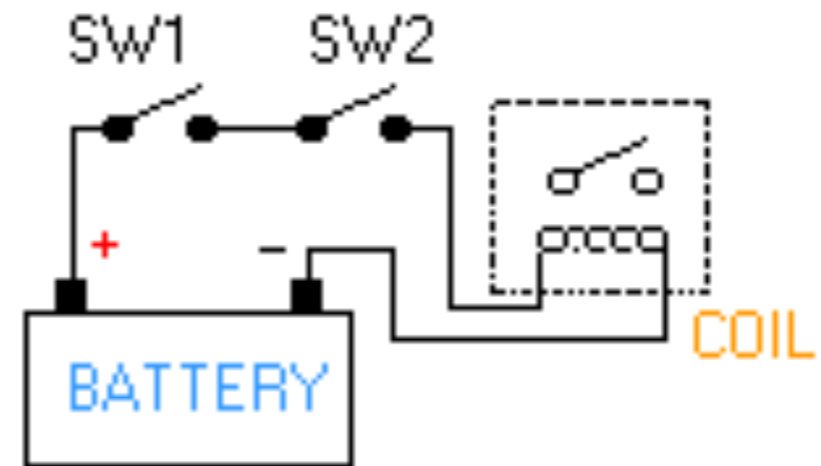

Circuito creado internamente en el PLC

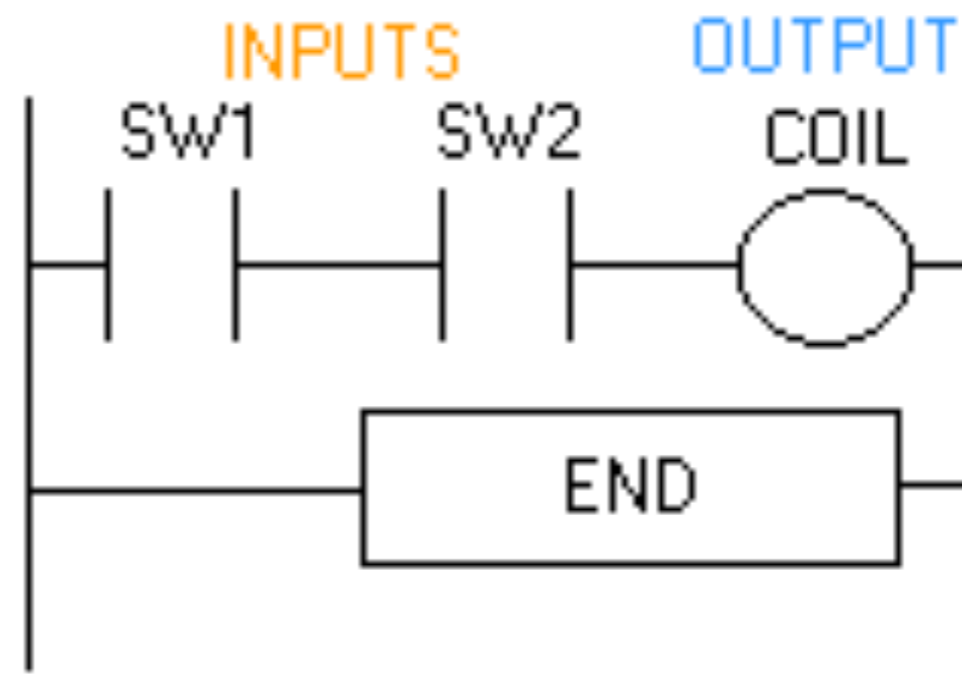

CONTACTOS - PSIM

Ejemplo

XIC
—| |—

XIO
—|/|—

OPE
—()—

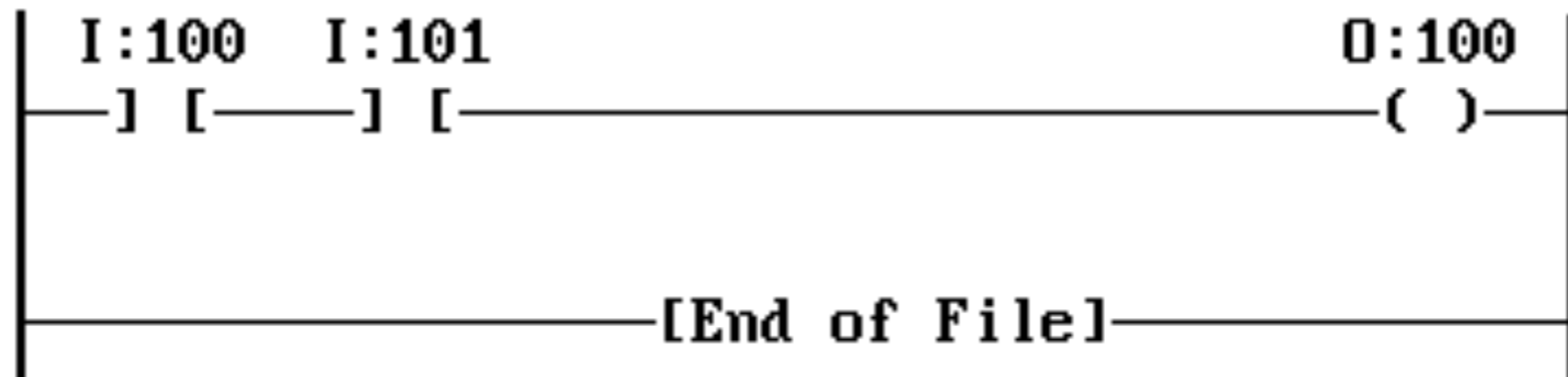

CONTACTOS - STEP7 (MARCA SIEMENS)

Contacto abierto



Contacto cerrado



Bobina de salida

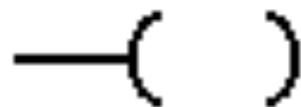

Ejemplo

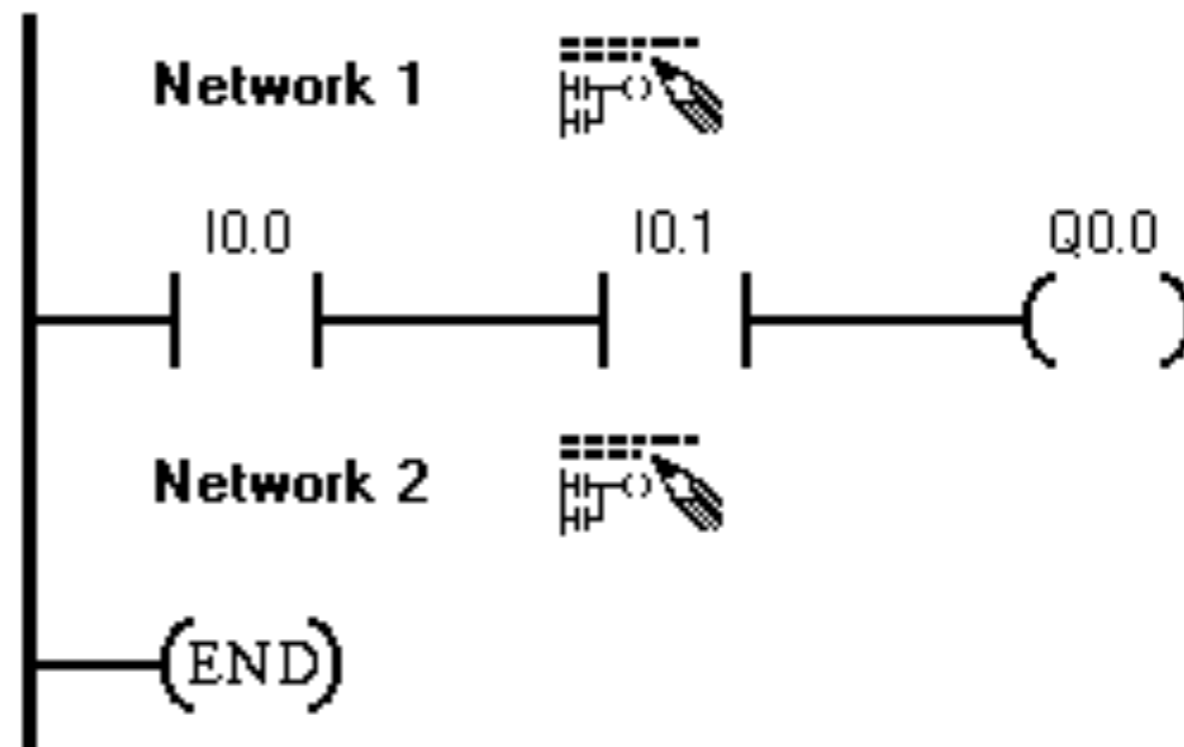

EJEMPLO - CONTROL DE NIVEL

- 2 entradas (NC)
- Cuando no están en el líquido están en la posición ON.
- 1 salida
- bomba

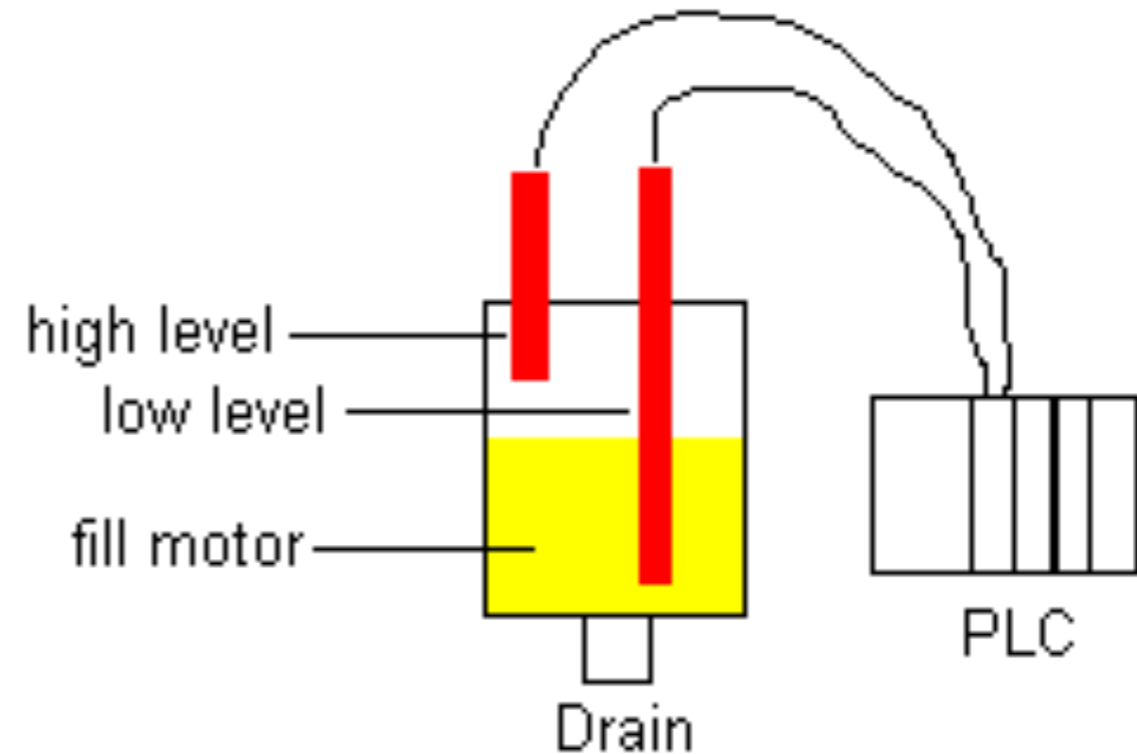

Dispensing oil from a tank

DEFINICIONES PROGRAMA

Señales	Direcciones
Sensor <u>bajo</u> (entrada)	0000
Sensor alto (entrada)	0001
Bomba (salidas)	0500
Relé auxiliar (interno)	1000

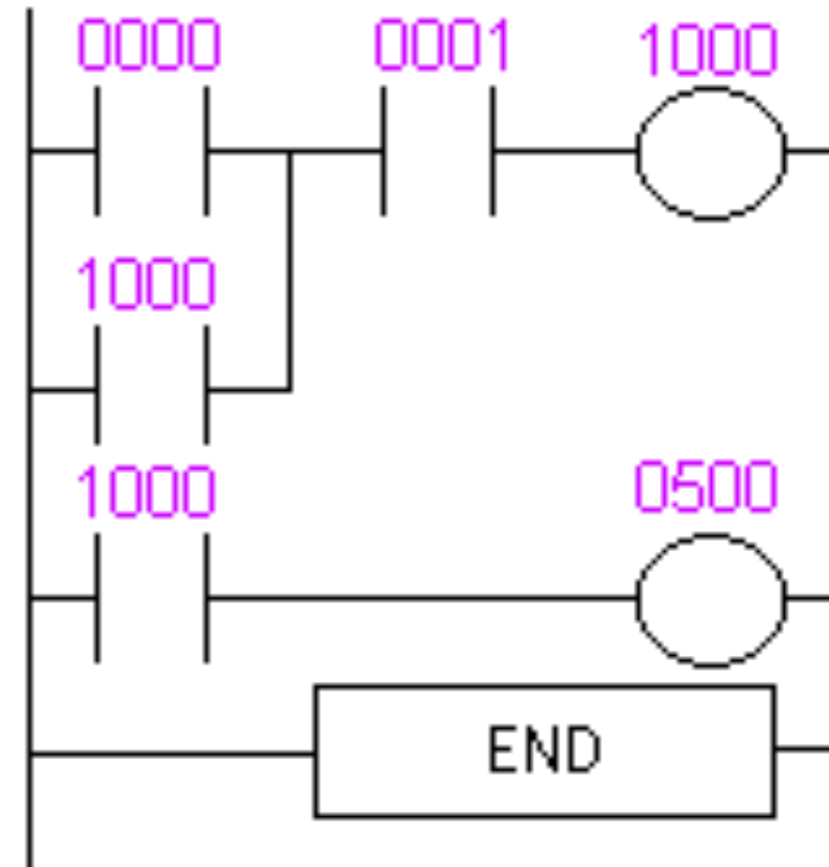

EJEMPLO FUNCIONAMIENTO 1

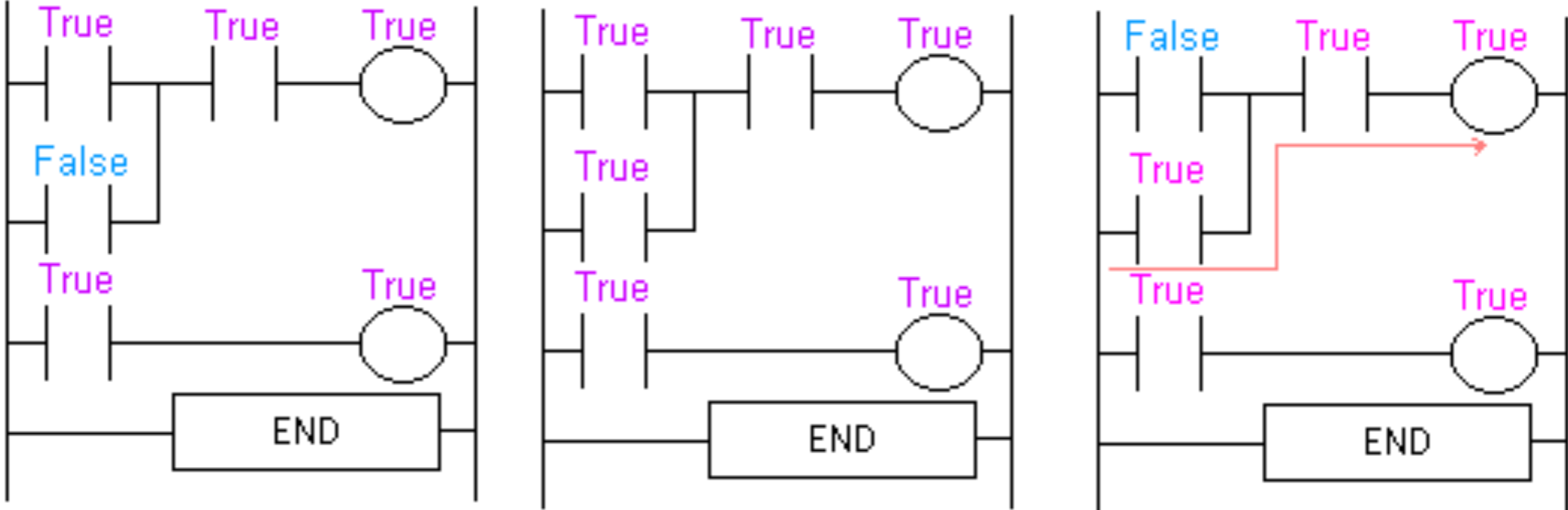

EJEMPLO FUNCIONAMIENTO 2

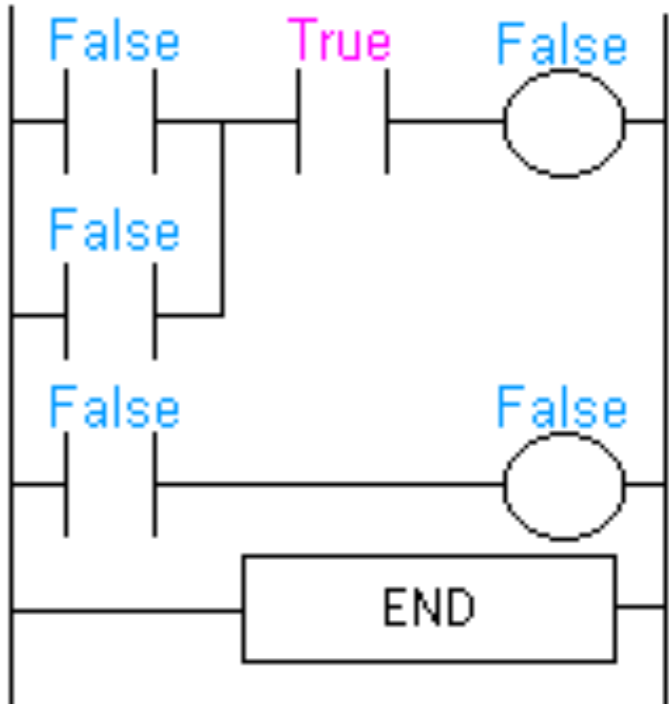
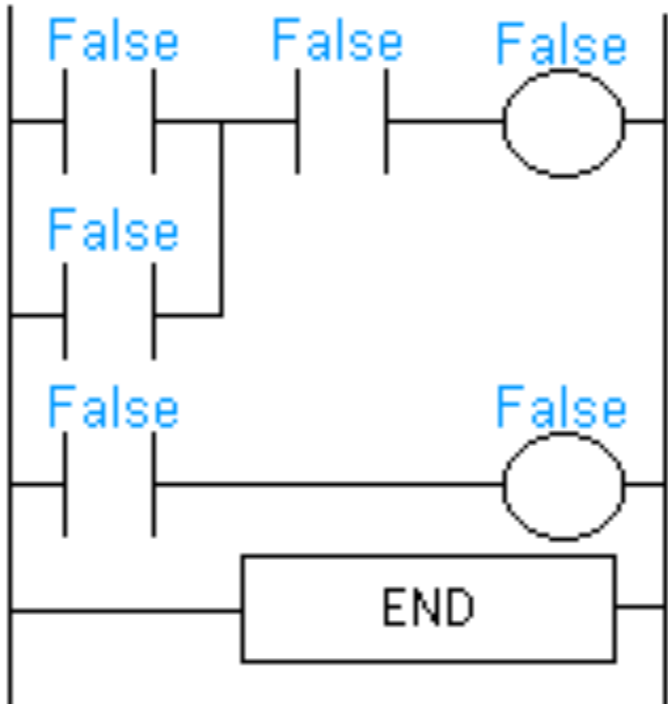
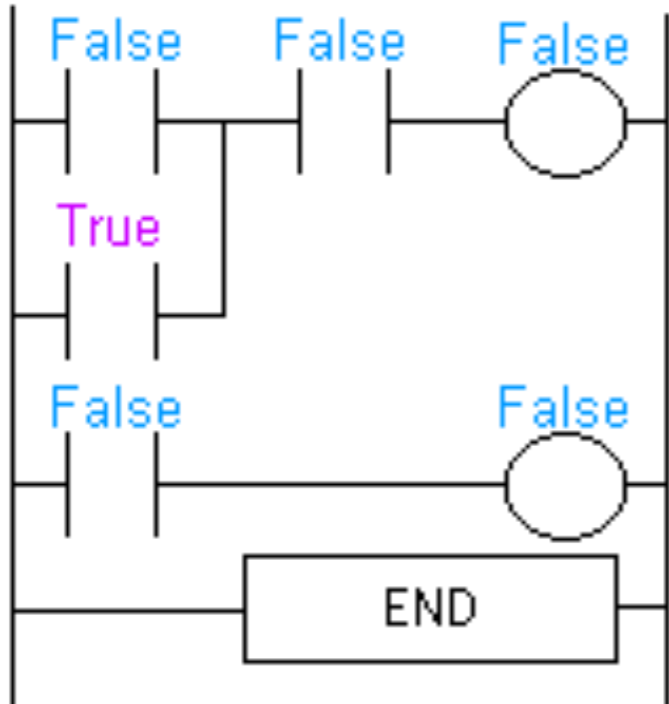

EJEMPLO ANIMACIÓN

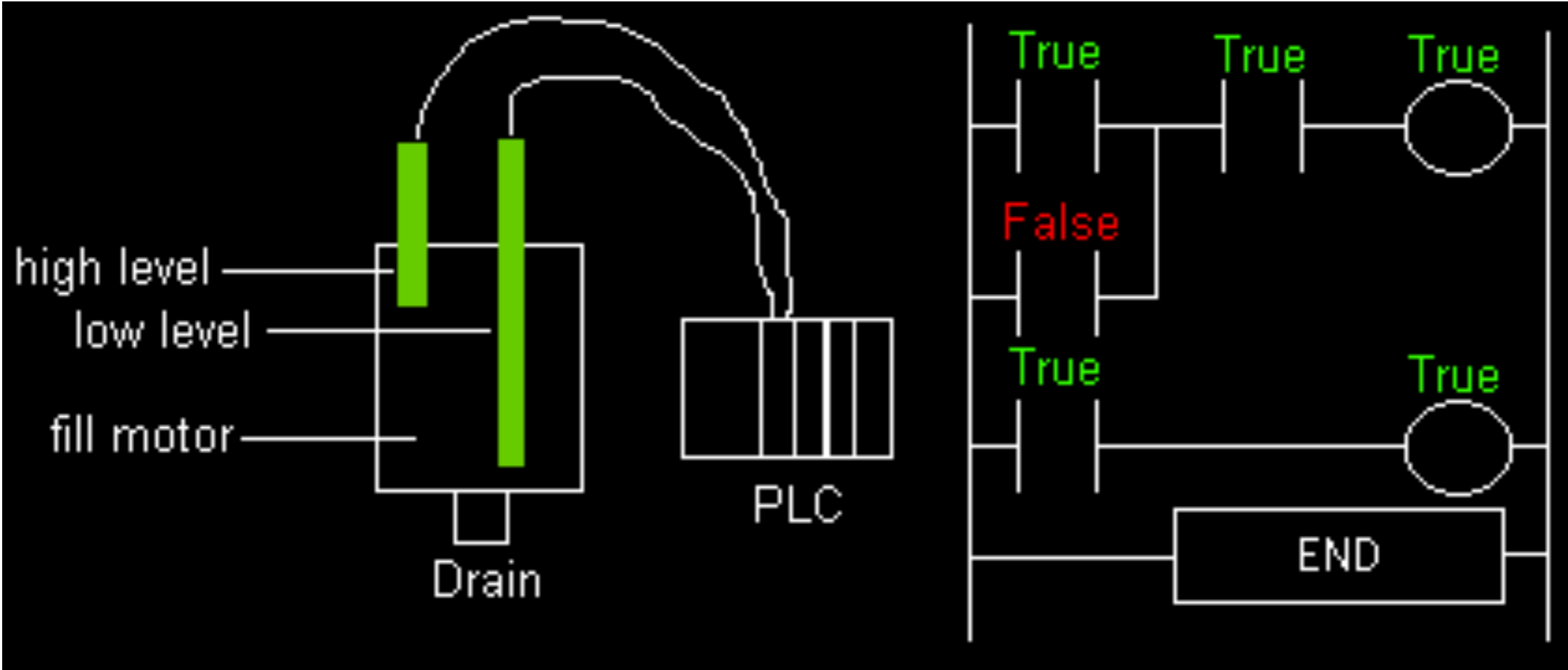

RETENCIÓN (LATCH)

- Latch (L)
 - SET
 - OTL (output latch)
- Unlatch (U)
 - RES (reset)
 - OTU (output unlatch)
 - RST (reset)

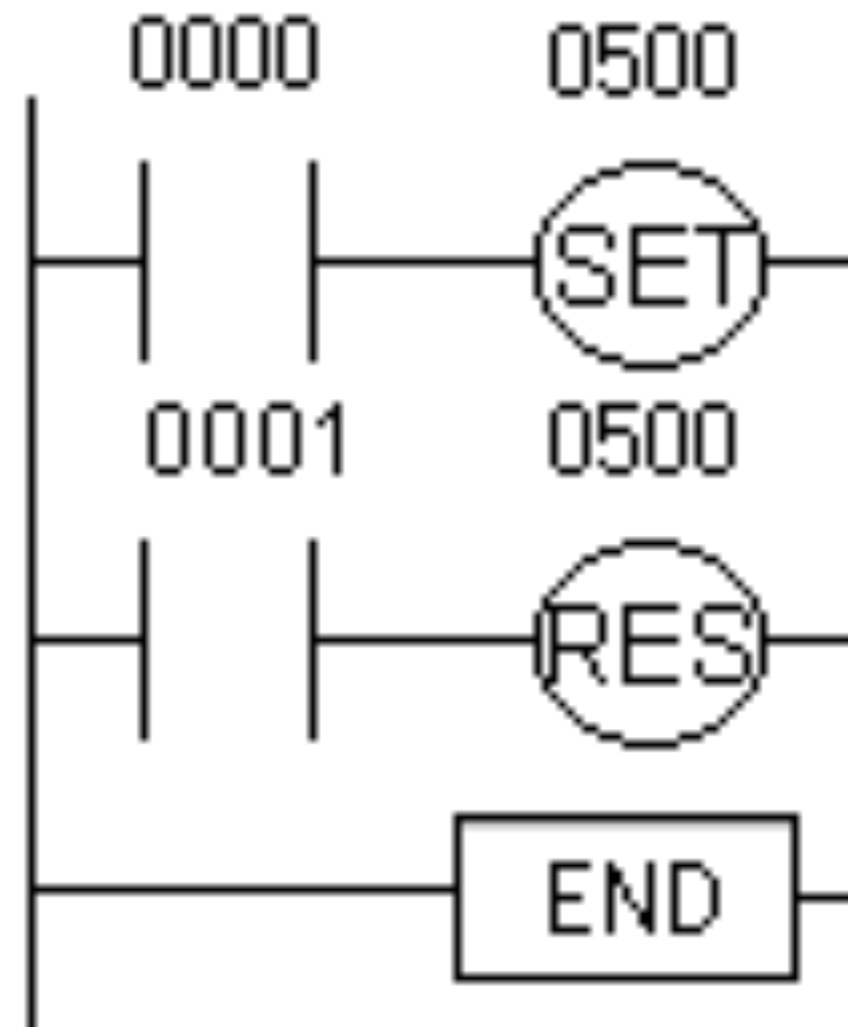

RETENCIÓN (LATCH) - PSIM

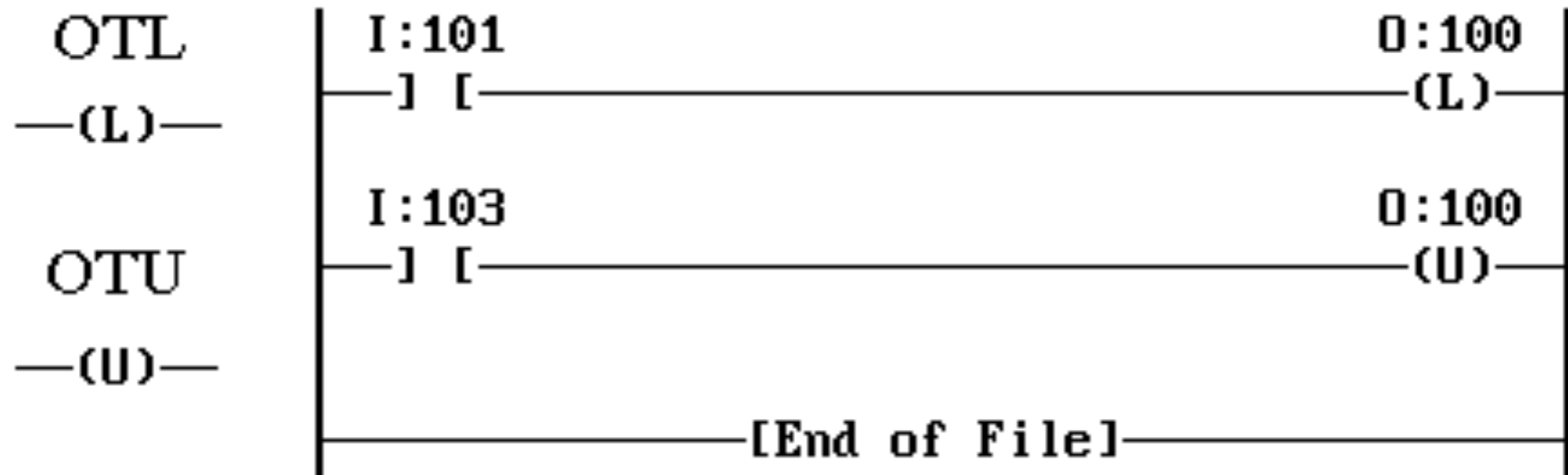

RETENCIÓN (LATCH) - STEP 7 (SIEMENS)

Poner a 1 (Set)

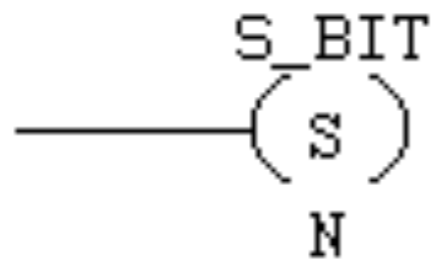

Poner a 0 (Reset)

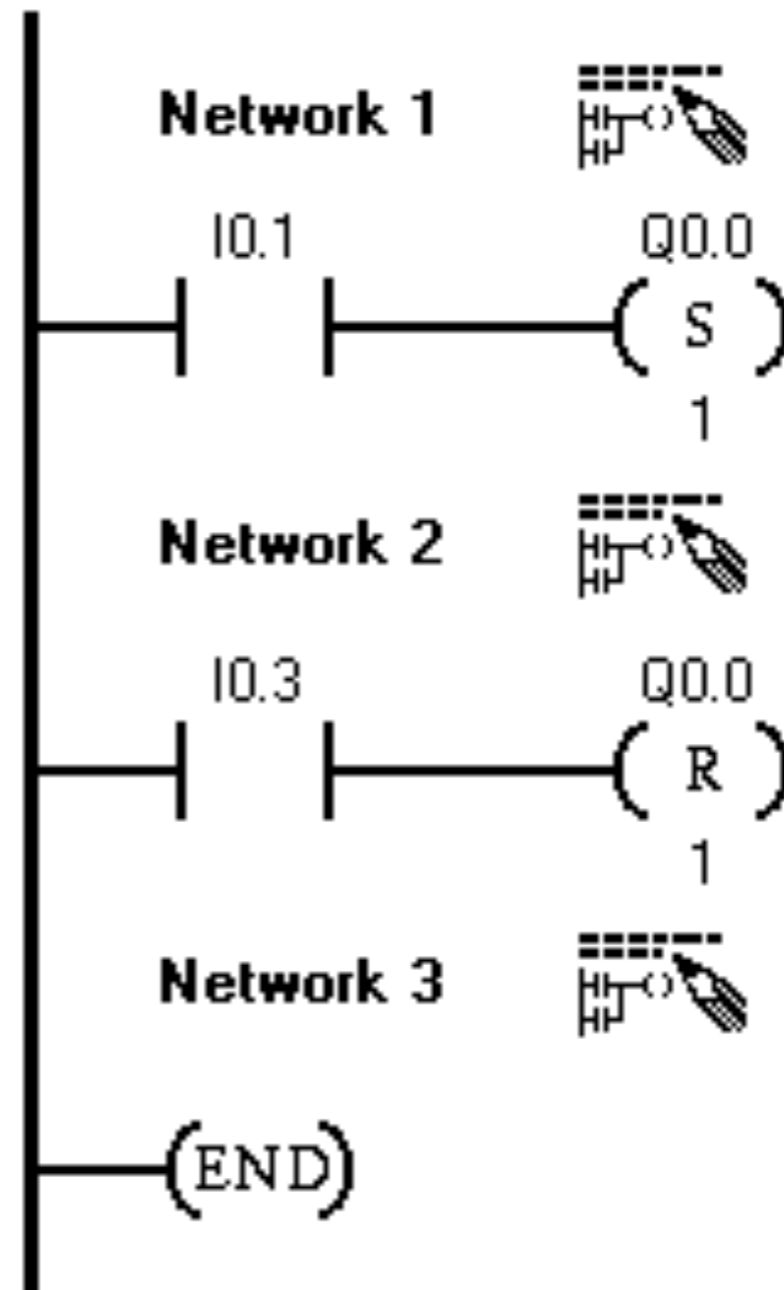
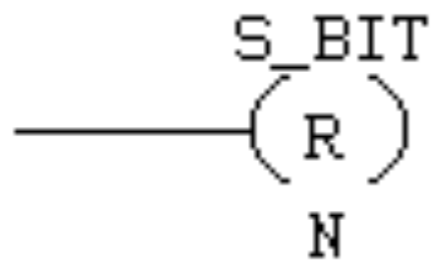

EJEMPLO - ANIMACIÓN

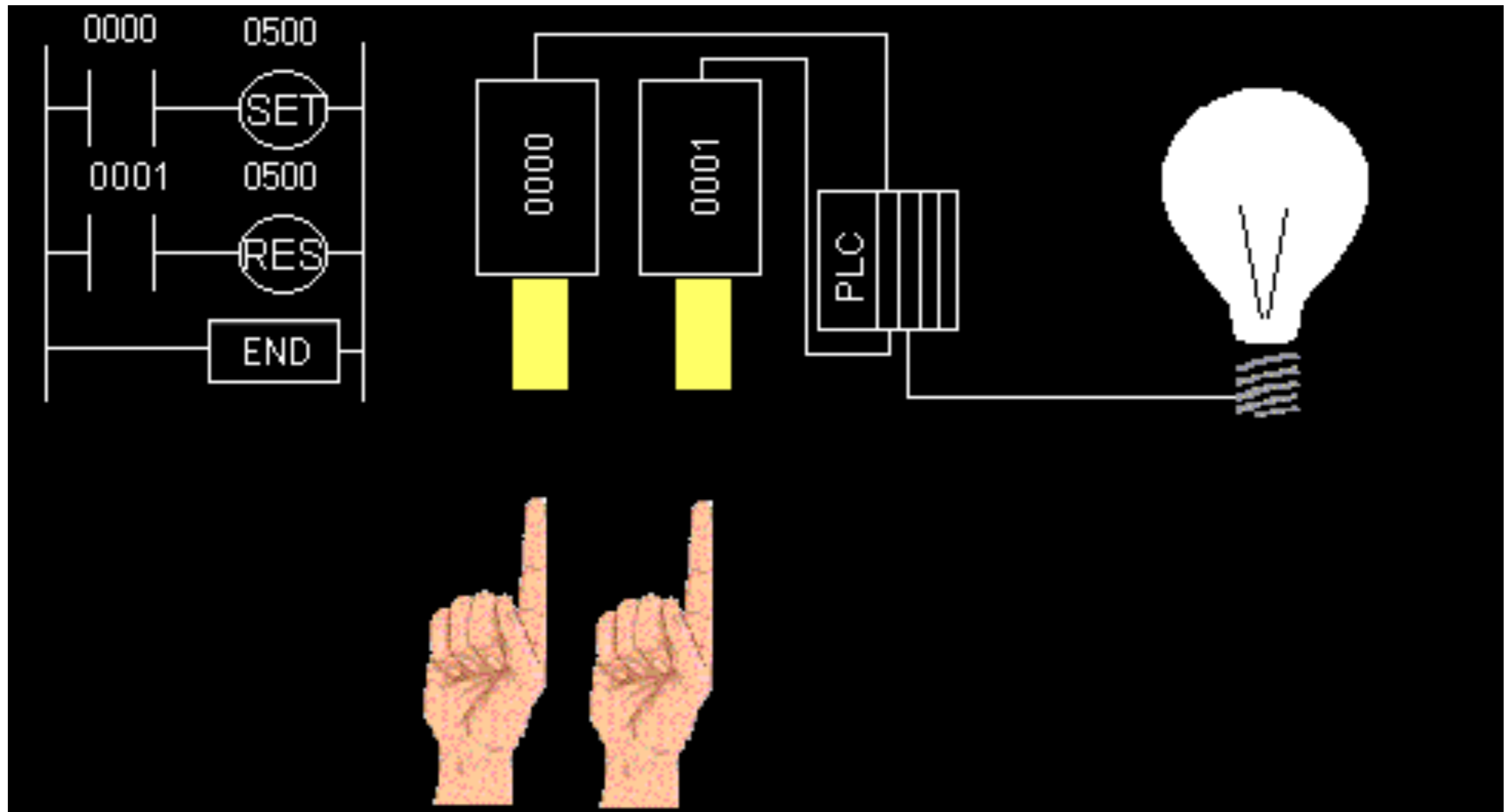

CONTADORES

- Diversidad (fabricantes).
 - up-counters (1,2,3...) (CTU, CNT, C, CTR)
 - down counters (9,8,7,...) (CTD)
 - up-down counters (UDC)
 - high-speed counters (HSC, CTH) (hardware)
- Valores
 - 0, 9999 / -32.768, +32.767 / 0, 65535

CONTADORES

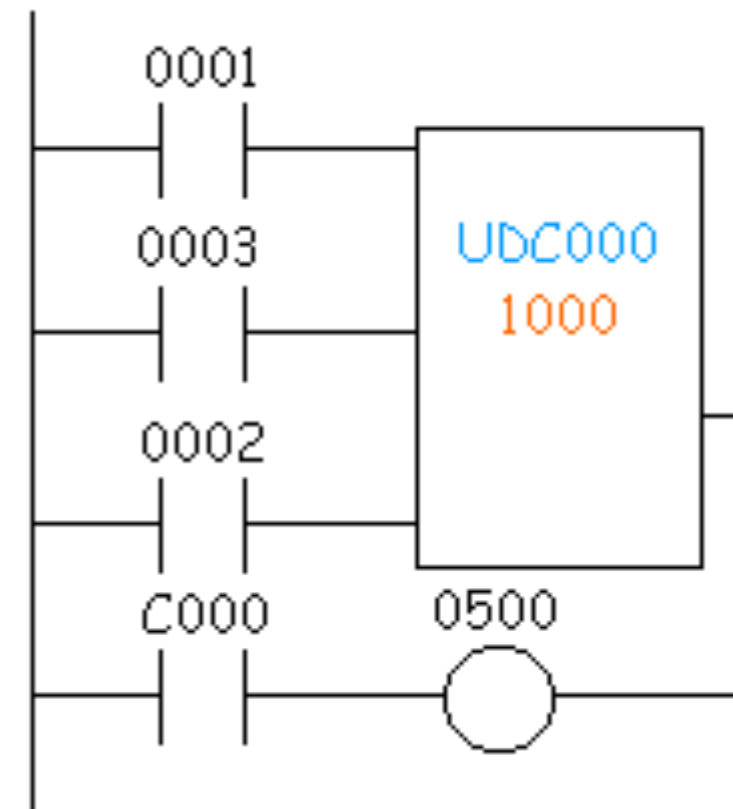
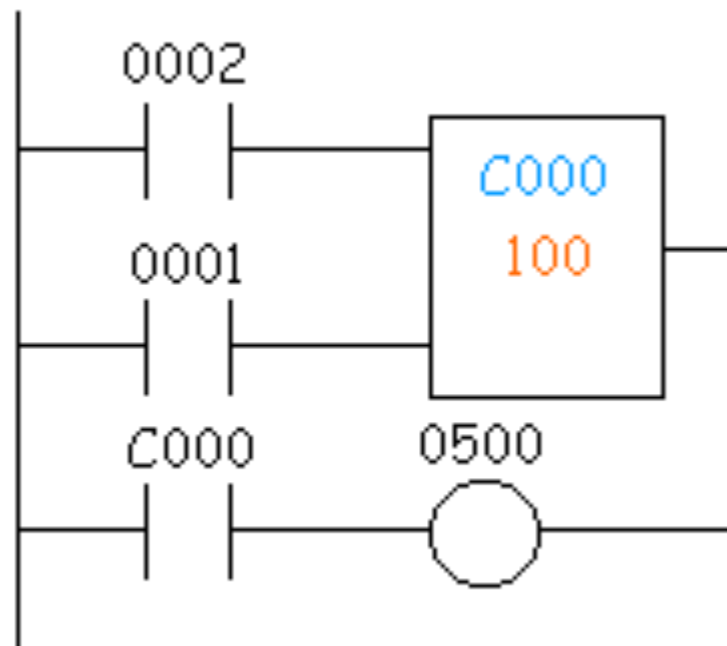
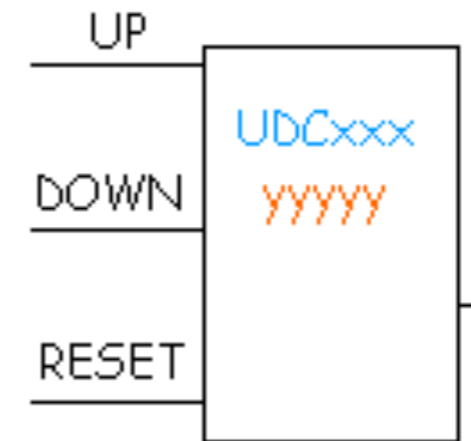
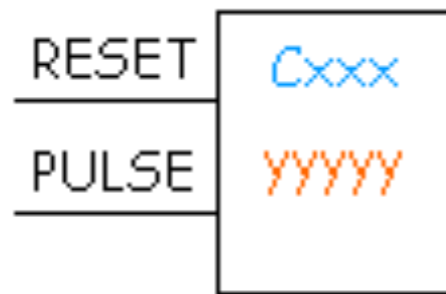

CONTADORES - PSIM

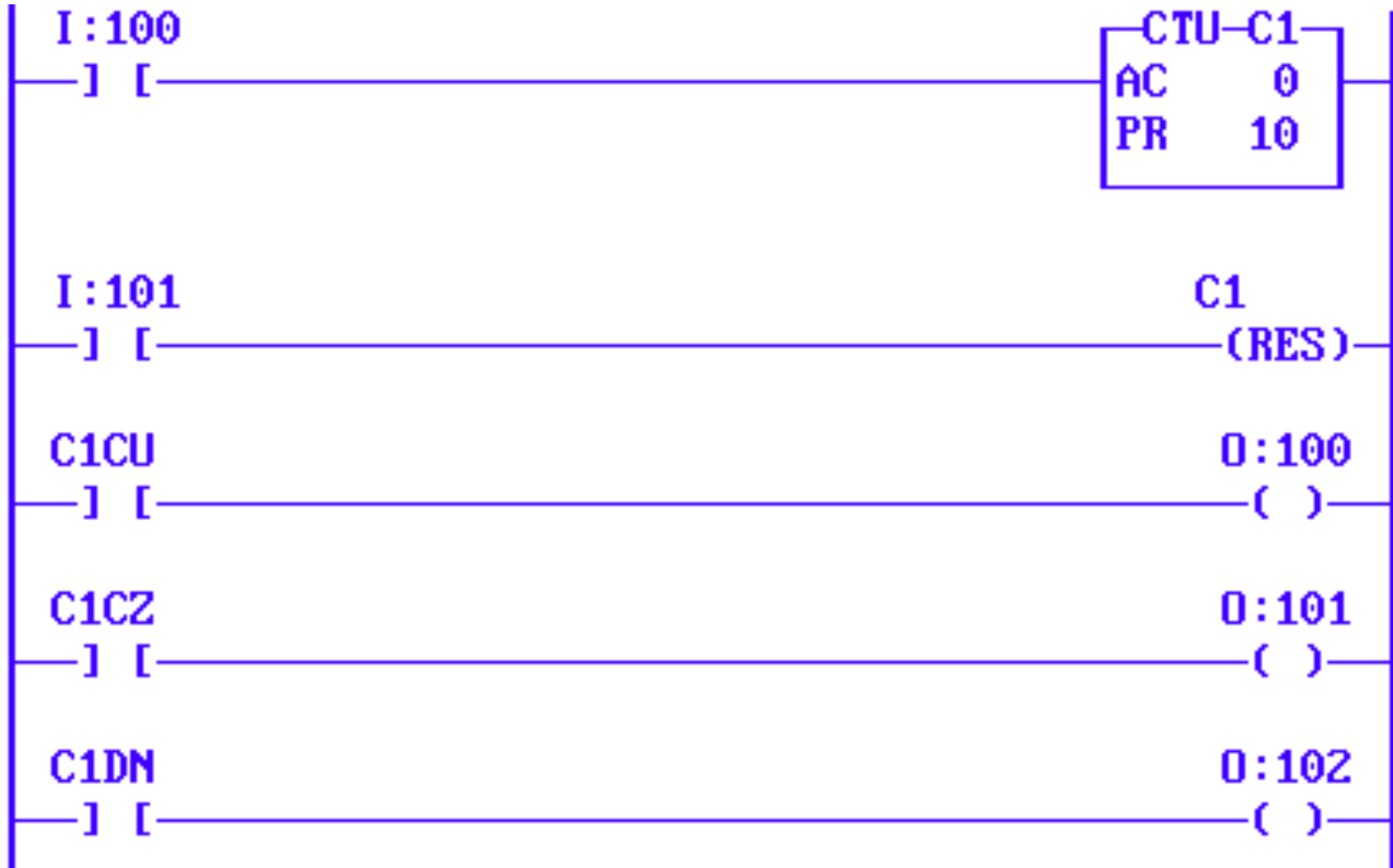

CONTADORES - STEP 7 (SIEMENS)

Contador adelante

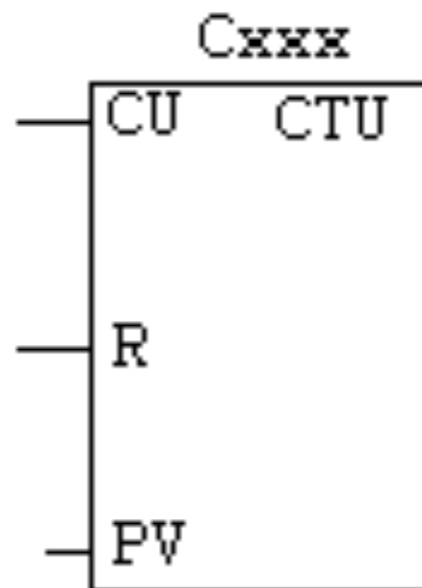

Contador adelante/atrás

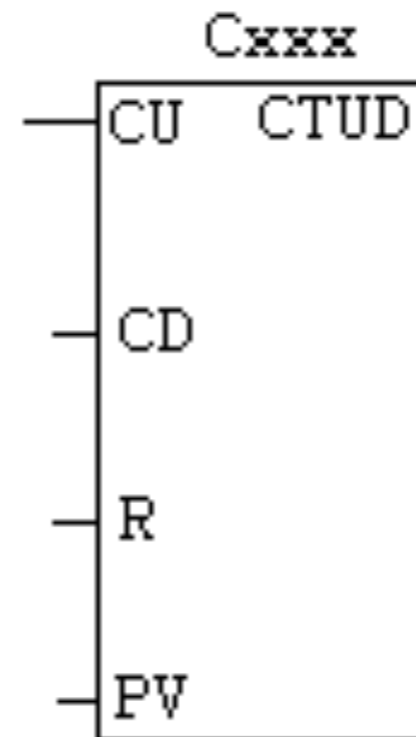

EJEMPLO - ANIMACIÓN

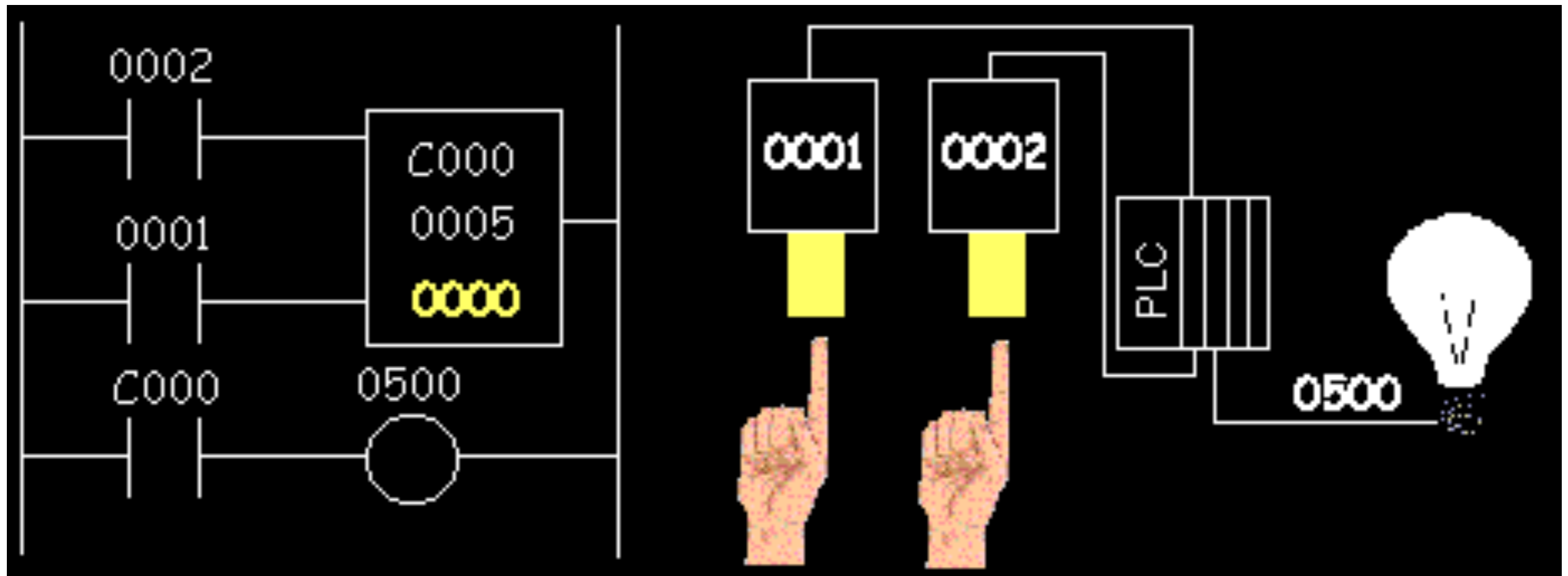

TIMERS

- 1 entrada lógica (habilitación).
- On-Delay timer (TON, TIM, TMR0)
- Off-Delay timer (TOF). Poco común.
- Retentive or Accumulating timer (RTO, TMRA).
 - Mantiene el valor actual.
 - 2 entradas
 - una empieza la cuenta
 - limpia el valor almacenado en memoria (RST)

TIMERS

- Timers especiales que funcionan como contadores con una base de tiempo elegible
- Incrementos : 1 ms a 1 s. Nombre refleja el incremento:
 - TMH (high speed timer).
 - TMS (super high speed timer).
 - TMRAF (accumulating fast timer).

TIMERS - PSIM

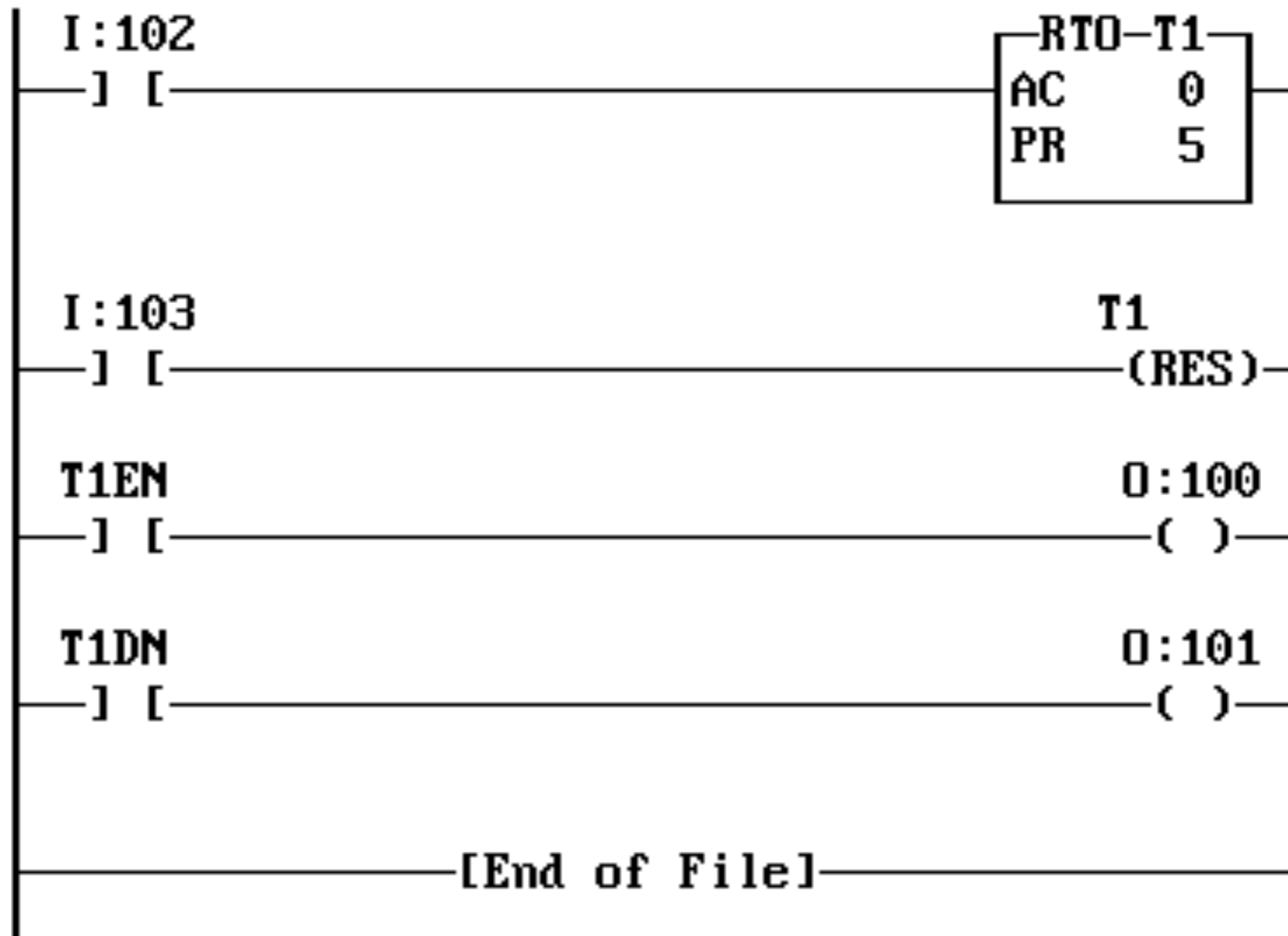

TIMERS - STEP 7 (SIEMENS)

Temporizador de retardo a la conexión

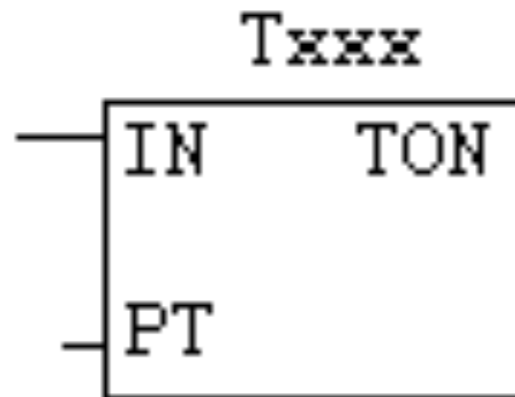

Temporizador de retardo a la conexión memorizado

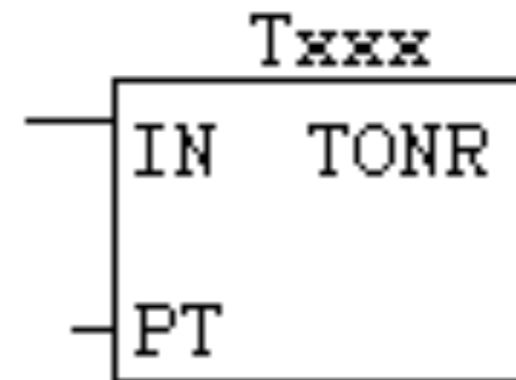

EJEMPLO - ANIMACIÓN

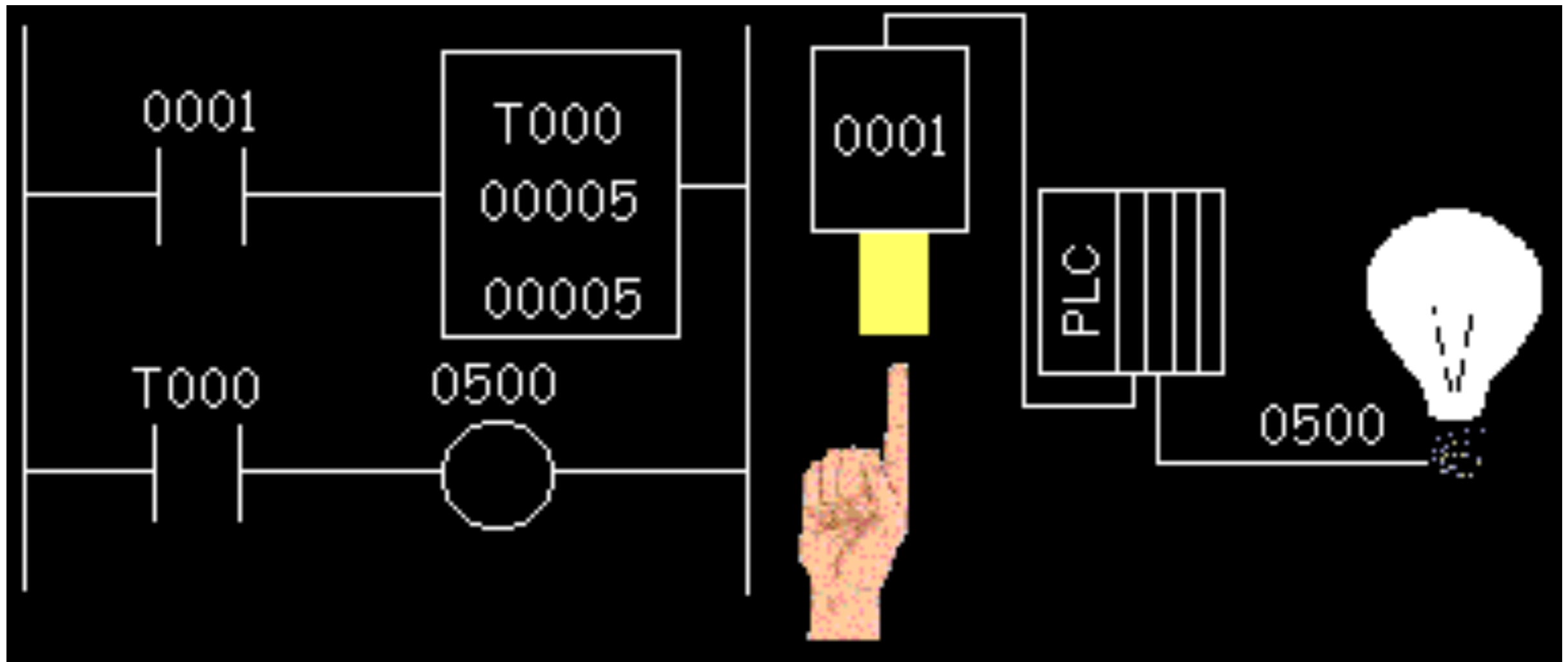

OTRAS INSTRUCCIONES

- ▶ Comparadores
 - ▶ Ejemplos (PSIM)
 - ▶ Hojas de ejercicios

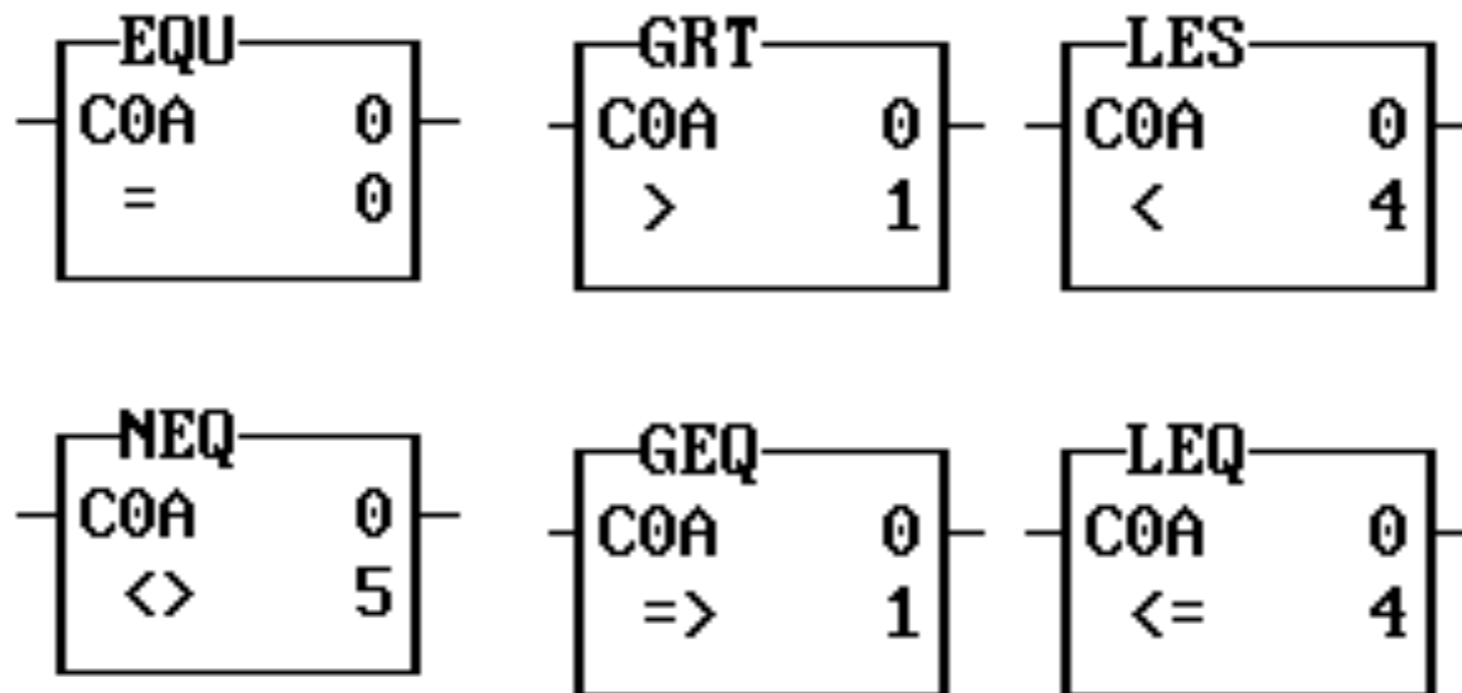

BIBLIOGRAFÍA Y OTROS LINKS

<http://www.plcs.net>

<http://www.sea.siemens.com/step>

<http://thelearningpit.com/plc/psim/doc/instructions.html>