

Features...

- High-performance, EEPROM-based programmable logic devices (PLDs) based on second-generation Multiple Array Matrix (MAX) architecture
- In-system programmability (ISP) via standard Joint Test Action Group (JTAG) interface (IEEE Std. 1149.1-1990) available in MAX 7000S devices
- Built-in JTAG boundary-scan test (BST) circuitry in MAX 7000S devices with 128 or more macrocells
- Complete EPLD family with logic densities ranging from 600 to 5,000 usable gates (see [Table 1](#))
- 5-ns pin-to-pin logic delays with up to 178.6-MHz counter frequencies (including interconnect)
- PCI-compliant devices available
- ClockBoost option for clock multiplication
- Open-drain output option in MAX 7000S devices
- Programmable macrocell flipflops with individual clear, preset, clock, and clock enable controls

Table 1. MAX 7000 Device Features *Note (1)*

Feature	EPM7032 EPM7032V EPM7032S	EPM7064 EPM7064S	EPM7096 EPM7096S	EPM7128E EPM7128S EPM7128SV	EPM7160E EPM7160S	EPM7192E EPM7192S	EPM7256E EPM7256S
Usable gates	600	1,250	1,800	2,500	3,200	3,750	5,000
Macrocells	32	64	96	128	160	192	256
Logic array blocks	2	4	6	8	10	12	16
Max. user I/O pins	36	68	76	100	104	124	164
t _{PD} (ns)	5 (12)	5	6	6 (10)	6	7.5	7.5
t _{SU} (ns)	4 (10)	4	5	5 (7)	5	6	6
t _{FSU} (ns)	2.5 (-)	2.5	2.5	2.5 (3)	2.5	3	3
t _{CO1} (ns)	3.5 (7)	3.5	4	4 (5)	4	4.5	4.5
f _{CNT} (MHz)	178.6 (90.9)	178.6	151.5	151.5 (100)	151.5	125	125

Notes:

(1) Values in parentheses are for 3.3-V devices.

...and More Features

- Programmable power-saving mode for 50% or greater power reduction in each macrocell
- Configurable expander product-term distribution, allowing up to 32 product terms per macrocell
- 44 to 208 pins available in J-lead (PLCC), pin-grid array (PGA), quad flat pack (QFP), and 1.0-mm thin quad flat pack (TQFP) packages
- Programmable security bit for protection of proprietary designs
- 3.3-V or 5.0-V operation
 - Full 3.3-V EPM7032V and EPM7128SV
 - 3.3-V or 5.0-V I/O pins on all devices (except 44-pin packages)
- Enhanced features available in MAX 7000E and MAX 7000S devices
 - Six pin- or logic-driven output enable signals
 - Two global clock signals with optional inversion
 - Enhanced interconnect resources for improved routability
 - Fast input setup times provided by a dedicated path from I/O pin to macrocell registers
 - Programmable output slew-rate control
- Software design support and automatic place-and-route provided by Altera's MAX+PLUS II development system on 486- and Pentium-based PCs, and Sun SPARCstation, HP 9000 Series 700, and IBM RISC System/6000 workstations
- Additional design entry and simulation support provided by EDIF, library of parameterized modules (LPM), Verilog HDL, VHDL, and other interfaces to popular EDA tools from manufacturers such as Cadence, Data I/O, Exemplar Logic, VeriBest, Mentor Graphics, OrCAD, Synopsys, and Viewlogic
- Programming support with Altera's Master Programming Unit (MPU) and BitBlaster serial download cable, as well as programming hardware from other manufacturers

General Description

The MAX 7000 family of high-density, high-performance programmable logic devices is based on Altera's second-generation MAX architecture. Fabricated with advanced CMOS technology, the EEPROM-based MAX 7000 family provides 600 to 5,000 usable gates, ISP, pin-to-pin delays as fast as 5 ns, and counter speeds of up to 178.6 MHz. MAX 7000S devices in the -5, -6, -7, and -10 speed grades as well as MAX 7000 and MAX 7000E devices in -5, -6, -7, -10P, -12P speed grades comply with the *PCI Local Bus Specification*, version 2. See [Table 2](#) for available speed grades.

Table 2. MAX 7000 Speed Grades

Device	Speed Grade									
	-5	-6	-7	-10P	-10	-12P	-12	-15	-15T	-20
EPM7032	✓ (1)	✓	✓		✓		✓	✓	✓	
EPM7032V							✓	✓		✓
EPM7032S	✓ (1)	✓ (1)	✓ (1)		✓ (1)			✓ (1)		
EPM7064		✓ (1)	✓		✓		✓	✓		
EPM7064S		✓ (1)	✓ (1)		✓ (1)			✓ (1)		
EPM7096		✓ (1)	✓		✓		✓	✓		
EPM7096S		✓ (1)	✓ (1)		✓ (1)			✓ (1)		
EPM7128E		✓ (1)	✓ (1)	✓	✓		✓	✓		✓
EPM7128S		✓ (1)	✓ (1)		✓ (1)			✓ (1)		
EPM7128SV					✓ (1)			✓ (1)		
EPM7160E			✓ (1)	✓	✓		✓	✓		✓
EPM7160S			✓ (1)		✓ (1)			✓ (1)		
EPM7192E			✓ (1)	✓ (1)	✓ (1)	✓	✓	✓		✓
EPM7192S			✓ (1)		✓ (1)			✓ (1)		
EPM7256E			✓ (1)		✓ (1)	✓	✓	✓		✓
EPM7256S			✓ (1)		✓ (1)			✓ (1)		

Note:

(1) This information is preliminary. Contact Altera Customer Marketing at (408) 894-7104 for product availability.

The higher-density members of the MAX 7000 family—called MAX 7000E devices—include the EPM7128E, EPM7160E, EPM7192E, and EPM7256E devices. These devices have several enhanced features: additional global clocking, additional output enable controls, enhanced interconnect resources, fast input registers, and a programmable slew rate.

In system programmable versions of the MAX 7000 family—called MAX 7000S devices—include the EPM7032S, EPM7064S, EPM7096S, EPM7128S, EPM7128SV, EPM7160S, EPM7192S and EPM7256S devices. MAX 7000S devices have the enhanced features of MAX 7000E devices as well as ISP, JTAG boundary-scan test (BST) circuitry in devices with 128 or more macrocells, and an open-drain output option. See [Table 3](#).

Feature	EPM7032 EPM7032V EPM7064 EPM7096	All MAX 7000E Devices	All MAX 7000S Devices
ISP via JTAG interface			✓
JTAG BST circuitry			✓ ⁽¹⁾
ClockBoost clock multiplier versions available			✓ ⁽²⁾
Open-drain output option			✓
Fast input registers		✓	✓
Six global output enables		✓	✓
Two global clocks		✓	✓
Slew-rate control		✓	✓
3.3-V I/O option	✓	✓	✓
Programmable register	✓	✓	✓
Parallel expanders	✓	✓	✓
Shared expanders	✓	✓	✓
Power-saving mode	✓	✓	✓
Security bit	✓	✓	✓
PCI-compliant versions available	✓	✓	✓

Notes:

- (1) Available in EPM7128S, EPM7160S, EPM7192S, and EPM7256S devices only.
- (2) Information on ClockBoost clock multiplier circuitry is preliminary. Contact your local Altera representative for more information.

The MAX 7000 architecture supports 100% TTL emulation and high-density integration of SSI, MSI, and LSI logic functions. It easily integrates multiple PLDs ranging from PALs, GALs, and 22V10s to MACH, pLSI, and FPGA devices. With speed, density, and I/O resources comparable to commonly used masked gate arrays, MAX 7000 devices are also ideal for gate-array prototyping. MAX 7000 devices are available in a wide range of packages, including plastic J-lead chip carrier (PLCC), ceramic pin-grid array (PGA), plastic quad flat pack (PQFP), power quad flat pack (RQFP), and 1-mm thin quad flat pack (TQFP) packages. See [Table 4](#).

Table 4. MAX 7000 Maximum User I/O Pins Notes (1), (2), (3)

Device	44-Pin PLCC	44-Pin PQFP	44-Pin TQFP	68-Pin PLCC	84-Pin PLCC	100-Pin PQFP	100-Pin TQFP	160-Pin PQFP	160-Pin PGA	192-Pin PGA	208-Pin RQFP
EPM7032	36	36	36								
EPM7032V	36		36								
EPM7032S	36		36								
EPM7064	36		36	52	68	68					
EPM7064S	36		36	52	68	68					
EPM7096				52	64	76					
EPM7096S				52	64	76	76				
EPM7128E					68	84		100			
EPM7128S					68	84	84, (4)	100			
EPM7128SV					68	84	84, (4)	100			
EPM7160E					64	84		104			
EPM7160S					64	84	84, (4)	104			
EPM7192E								124	124		
EPM7192S								124			
EPM7256E								132, (4)		164	164
EPM7256S								132, (4)			164

Notes:

- (1) Contact Altera for up-to-date information on available device package options.
- (2) For the MAX 7000S JTAG interface, four I/O pins become JTAG pins.
- (3) Information on MAX 7000S devices is preliminary.
- (4) Perform a complete thermal analysis before committing a design to this device package. See *Operating Requirements for Altera Devices Data Sheet* in this data book for more information.

MAX 7000 devices use CMOS EEPROM cells to implement logic functions. The user-configurable MAX 7000 architecture accommodates a variety of independent combinatorial and sequential logic functions. The devices can be reprogrammed for quick and efficient iterations during design development and debug cycles, and can be programmed and erased over 100 times.

MAX 7000 devices contain from 32 to 256 macrocells that are combined into groups of 16 macrocells, called logic array blocks (LABs). Each macrocell has a programmable-AND/fixed-OR array and a configurable register with independently programmable clock, clock enable, clear, and preset functions. To build complex logic functions, each macrocell can be supplemented with both shareable expander product terms and high-speed parallel expander product terms to provide up to 32 product terms per macrocell.

The MAX 7000 family provides programmable speed/power optimization. Speed-critical portions of a design can run at high speed/full power, while the remaining portions run at reduced speed/low power. This speed/power optimization feature enables the designer to configure one or more macrocells to operate at 50% or lower power while adding only a nominal timing delay. MAX 7000E and MAX 7000S devices also provide an option that reduces the slew rate of the output buffers, minimizing noise transients when non-speed-critical signals are switching. The output drivers of all MAX 7000 devices (except 44-pin devices) can be set for either 3.3-V or 5.0-V operation, allowing MAX 7000 devices to be used in mixed-voltage systems.

The MAX 7000 family is supported by Altera's MAX+PLUS II development system, a single, integrated package that offers schematic, text—including the Altera Hardware Description Language (AHDL)—and waveform design entry; compilation and logic synthesis; simulation and timing analysis; and device programming. MAX+PLUS II provides EDIF 2.0.0 and 3.0.0, LPM, VHDL, Verilog HDL, and other interfaces for additional design entry and simulation support from other industry-standard PC- and workstation-based EDA tools. MAX+PLUS II runs on 486- and Pentium-based PCs, and Sun SPARCstation, HP 9000 Series 700, and IBM RISC System/6000 workstations.



For more information on development tools, go to the [MAX+PLUS II Programmable Logic Development System & Software Data Sheet](#) in this data book.

Functional Description

The MAX 7000 architecture includes the following elements:

- Logic array blocks
- Macrocells
- Expander product terms (shareable and parallel)
- Programmable interconnect array
- I/O control blocks

The MAX 7000 architecture includes four dedicated inputs that can be used as general-purpose inputs or as high-speed, global control signals (clock, clear, and two output enable signals) for each macrocell and I/O pin. [Figure 1](#) shows the architecture of the EPM7032, EPM7032V, EPM7064, and EPM7096 devices.

Figure 1. EPM7032, EPM7032V, EPM7064 & EPM7096 Device Block Diagram

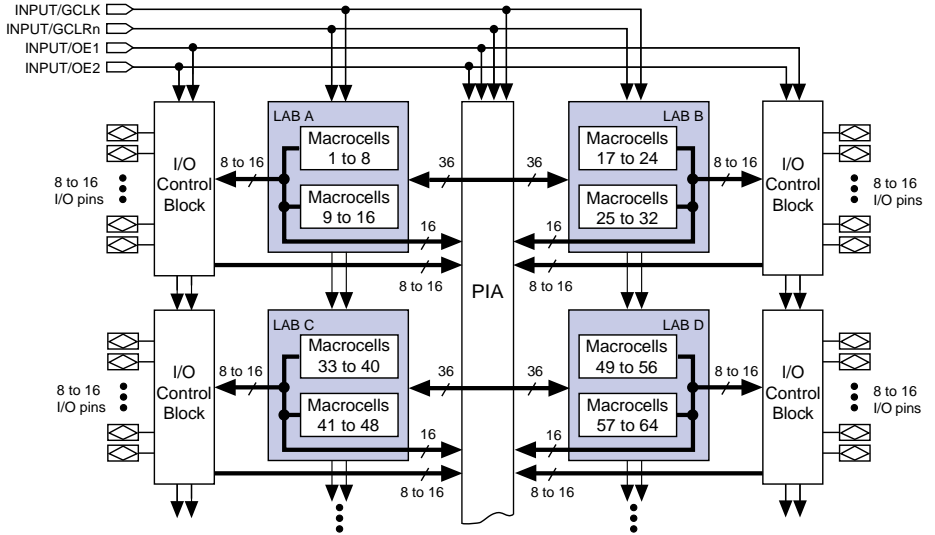
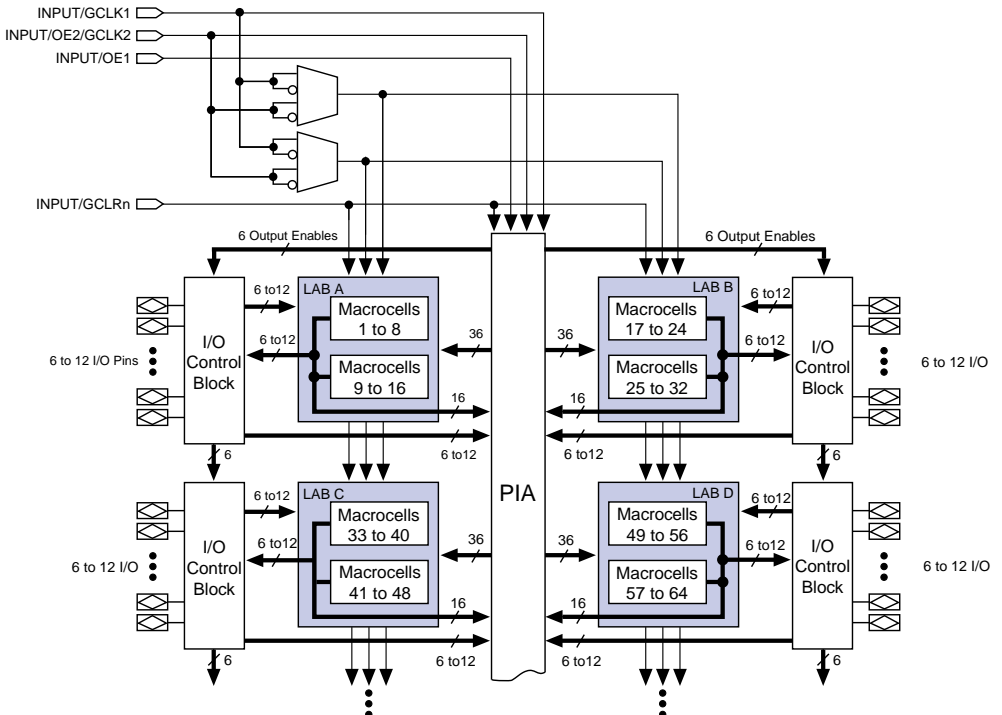

Figure 2 shows the architecture of MAX 7000E and MAX 7000S devices.

Figure 2. MAX 7000E & MAX 7000S Device Block Diagram



Logic Array Blocks

The MAX 7000 device architecture is based on the linking of high-performance, flexible, logic array modules called logic array blocks (LABs). LABs consist of 16-macrocell arrays, as shown in Figures 1 and 2. Multiple LABs are linked together via the programmable interconnect array (PIA), a global bus that is fed by all dedicated inputs, I/O pins, and macrocells.

Each LAB is fed by the following signals:

- 36 signals from the PIA that are used for general logic inputs
- Global controls that are used for secondary register functions
- Direct input paths from I/O pins to the registers that are used for fast setup times for MAX 7000E and MAX 7000S devices

Macrocells

The MAX 7000 macrocell can be individually configured for both sequential and combinatorial logic operation. The macrocell consists of three functional blocks: the logic array, the product-term select matrix, and the programmable register. The macrocell of EPM7032, EPM7032V, EPM7064, and EPM7096 devices is shown in Figure 3.

Figure 3. EPM7032, EPM7032V, EPM7064 & EPM7096 Device Macrocell

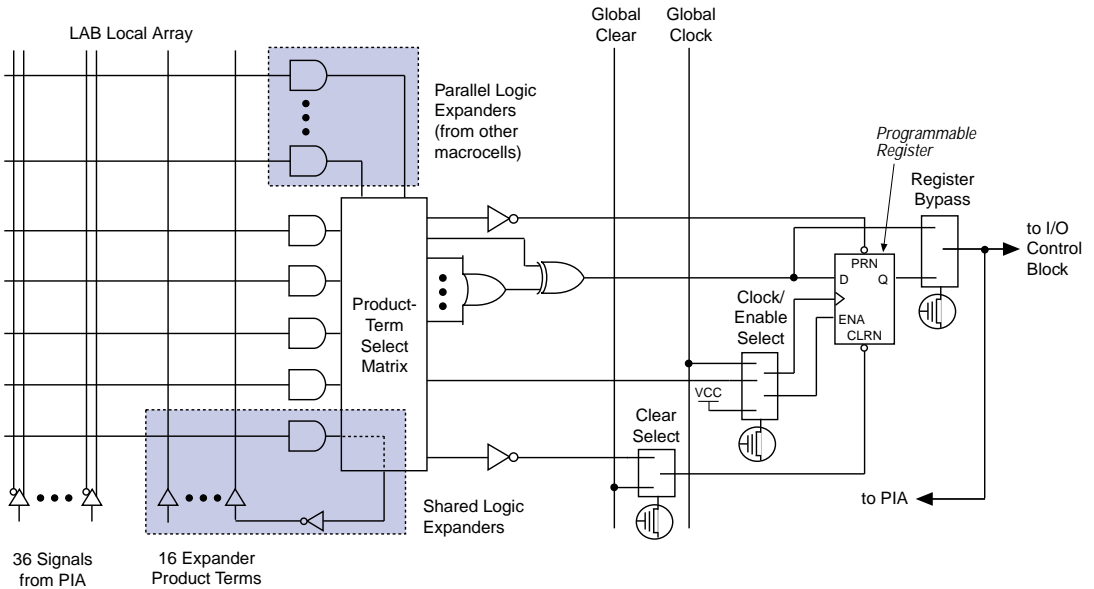

The macrocell of MAX 7000E and MAX 7000S devices is shown in Figure 4.

Figure 4. MAX 7000E & MAX 7000S Device Macrocell

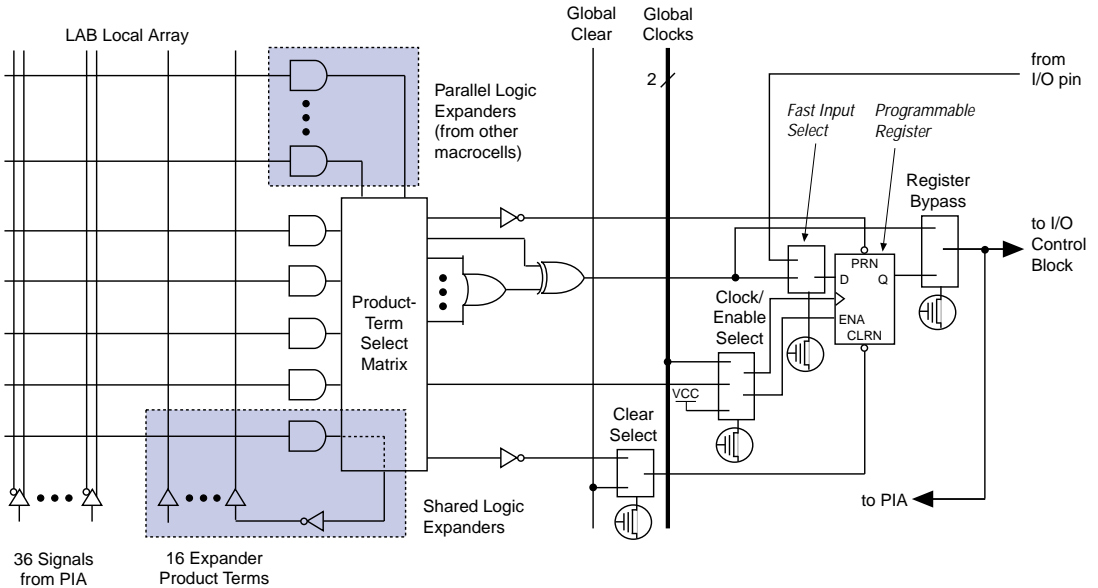

Combinatorial logic is implemented in the logic array, which provides five product terms per macrocell. The product-term select matrix allocates these product terms for use as either primary logic inputs (to the OR and XOR gates) to implement combinatorial functions, or as secondary inputs to the macrocell's register clear, preset, clock, and clock enable control functions. Two kinds of expander product terms ("expanders") are available to supplement macrocell logic resources:

- Shareable expanders, which are inverted product terms that are fed back into the logic array
- Parallel expanders, which are product terms borrowed from adjacent macrocells

MAX+PLUS II automatically optimizes product-term allocation according to the logic requirements of the design.

For registered functions, each macrocell flipflop can be individually programmed to implement D, T, JK, or SR operation with programmable clock control. The flipflop can be bypassed for combinatorial operation. During design entry, the designer specifies the desired flipflop type; MAX+PLUS II then selects the most efficient flipflop operation for each registered function to optimize resource utilization.

Each programmable register can be clocked in three different modes:

- By a global clock signal. This mode achieves the fastest clock-to-output performance.
- By a global clock signal and enabled by an active-high clock enable. This mode provides an enable on each flipflop while still achieving the fast clock-to-output performance of the global clock.
- By an array clock implemented with a product term. In this mode, the flipflop can be clocked by signals from buried macrocells or I/O pins.

In the EPM7032, EPM7032V, EPM7064, and EPM7096 devices, the global clock signal is available from a dedicated clock pin, GCLK, as shown in [Figure 1](#). In MAX 7000E and MAX 7000S devices, two global clock signals are available. As shown in [Figure 2](#), these global clock signals can be the true or the complement of either of the global clock pins, GCLK1 or GCLK2.

Each register also supports asynchronous preset and clear functions. As shown in [Figures 3 and 4](#), the product-term select matrix allocates product terms to control these operations. Although the product-term-driven preset and clear of the register are active high, active-low control can be obtained by inverting the signal within the logic array. In addition, each register clear function can be individually driven by the active-low dedicated global clear pin (GCLRn).

All MAX 7000E and MAX 7000S I/O pins have a fast input path to a macrocell register. This dedicated path allows a signal to bypass the PIA and combinatorial logic and be clocked to an input D flipflop with an extremely fast (3-ns) input setup time.

Expander Product Terms

Although most logic functions can be implemented with the five product terms available in each macrocell, the more complex logic functions require additional product terms. Another macrocell can be used to supply the required logic resources; however, the MAX 7000 architecture also offers both shareable and parallel expander product terms (“expanders”) that provide additional product terms directly to any macrocell in the same LAB. These expanders help ensure that logic is synthesized with the fewest possible logic resources to obtain the fastest possible speed.

Shareable Expanders

Each LAB has 16 shareable expanders that can be viewed as a pool of uncommitted single product terms (one from each macrocell) with inverted outputs that feed back into the logic array. Each shareable expander can be used and shared by any or all macrocells in the LAB to build complex logic functions. A small delay (t_{SEXP}) is incurred when shareable expanders are used. Figure 5 shows how shareable expanders can feed multiple macrocells.

Figure 5. Shareable Expanders

Shareable expanders can be shared by any or all macrocells in an LAB.

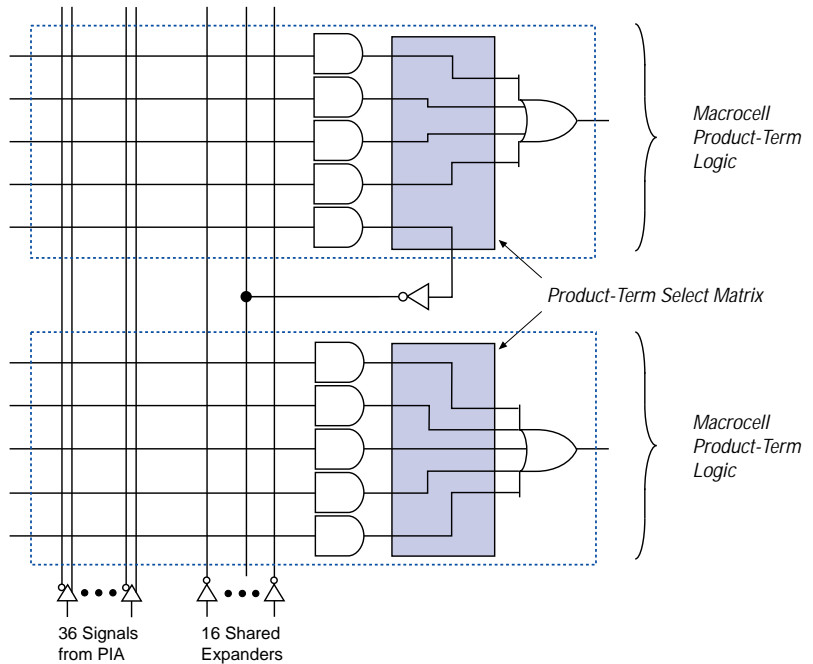

Parallel Expanders

Parallel expanders are unused product terms that can be allocated to a neighboring macrocell to implement fast, complex logic functions. Parallel expanders allow up to 20 product terms to directly feed the macrocell OR logic, with 5 product terms provided by the macrocell and 15 parallel expanders provided by neighboring macrocells in the LAB.

The MAX+PLUS II Compiler can automatically allocate up to 3 sets of up to 5 parallel expanders to the macrocells that require additional product terms. Each set of 5 parallel expanders incurs a small, incremental timing delay (t_{PEXP}). For example, if a macrocell requires 14 product terms, the Compiler uses the 5 dedicated product terms within the macrocell and allocates 2 sets of parallel expanders; the first set includes 5 product terms and the second set includes 4 product terms, increasing the total delay by $2 \times t_{PEXP}$.

Two groups of 8 macrocells within each LAB (e.g., macrocells 1 to 8 and 9 to 16) form 2 chains to lend or borrow parallel expanders. A macrocell borrows parallel expanders from lower-numbered macrocells. For example, macrocell 8 can borrow parallel expanders from macrocell 7, from macrocells 7 and 6, or from macrocells 7, 6, and 5. Within each group of 8, the lowest-numbered macrocell can only lend parallel expanders and the highest-numbered macrocell can only borrow them. Figure 6 shows how parallel expanders can be borrowed from a neighboring macrocell.

Figure 6. Parallel Expanders

Unused product terms in a macrocell can be allocated to a neighboring macrocell.

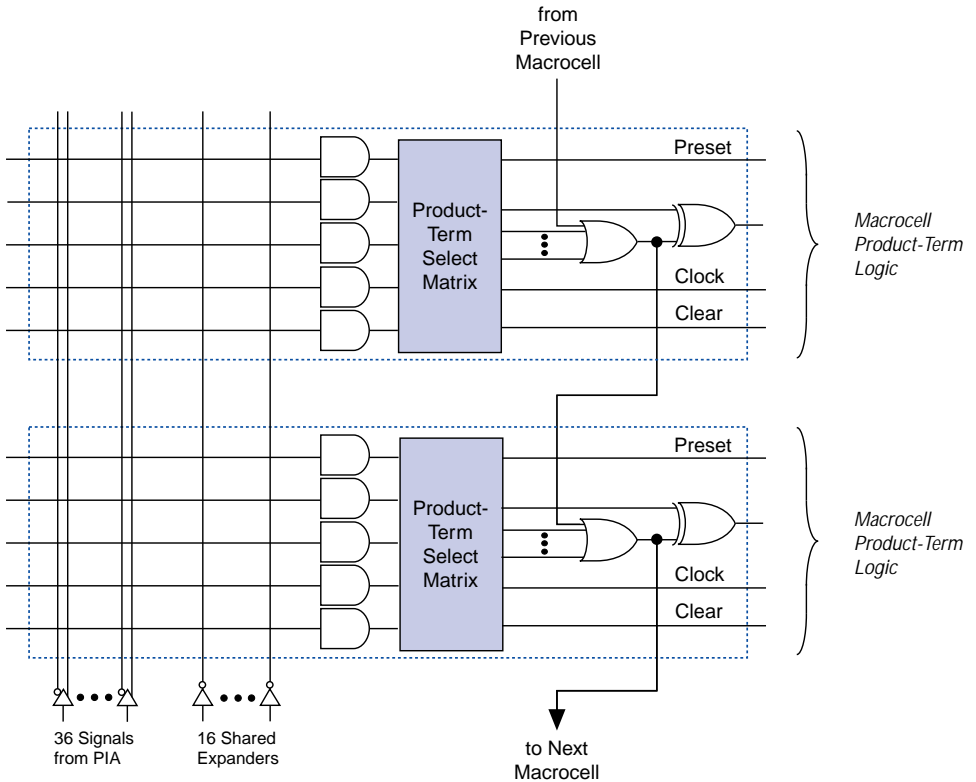

Programmable Interconnect Array

Logic is routed between LABs on the programmable interconnect array (PIA). This global bus is a programmable path that connects any signal source to any destination on the device. All MAX 7000 dedicated inputs, I/O pins, and macrocell outputs feed the PIA, which makes the signals available throughout the entire device. Only the signals required by each LAB are actually routed from the PIA into the LAB. Figure 7 shows how the PIA signals are routed into the LAB. An EEPROM cell controls one input to a 2-input AND gate, which selects a PIA signal to drive into the LAB.

Figure 7. PIA Routing

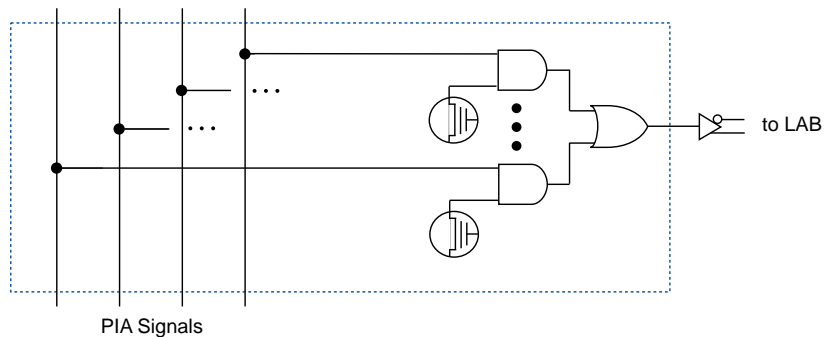

While the routing delays of channel-based routing schemes in masked or field-programmable gate arrays (FPGAs) are cumulative, variable, and path-dependent, the MAX 7000 PIA has a fixed delay. The PIA thus eliminates skew between signals and makes timing performance easy to predict.

I/O Control Blocks

The I/O control block allows each I/O pin to be individually configured for input, output, or bidirectional operation. All I/O pins have a tri-state buffer that is individually controlled by one of the global output enable signals or directly connected to GND or VCC. Figure 8 shows the I/O control block for the MAX 7000 family. The I/O control block of EPM7032, EPM7032V, EPM7064, and EPM7096 devices has two global output enable signals that are driven by two dedicated active-low output enable pins (OE1 and OE2). The I/O control block of MAX 7000E and MAX 7000S devices has six global output enable signals, that are driven by the true or complement of two output enable signals, a subset of the I/O pins, or a subset of the I/O macrocells.

Figure 8. I/O Control Block of MAX 7000 Devices

EPM7032, EPM7032V, EPM7064 & EPM7096 Devices

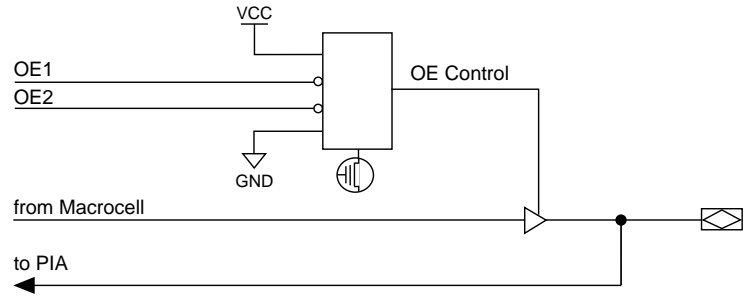

MAX 7000E & MAX 7000S Devices

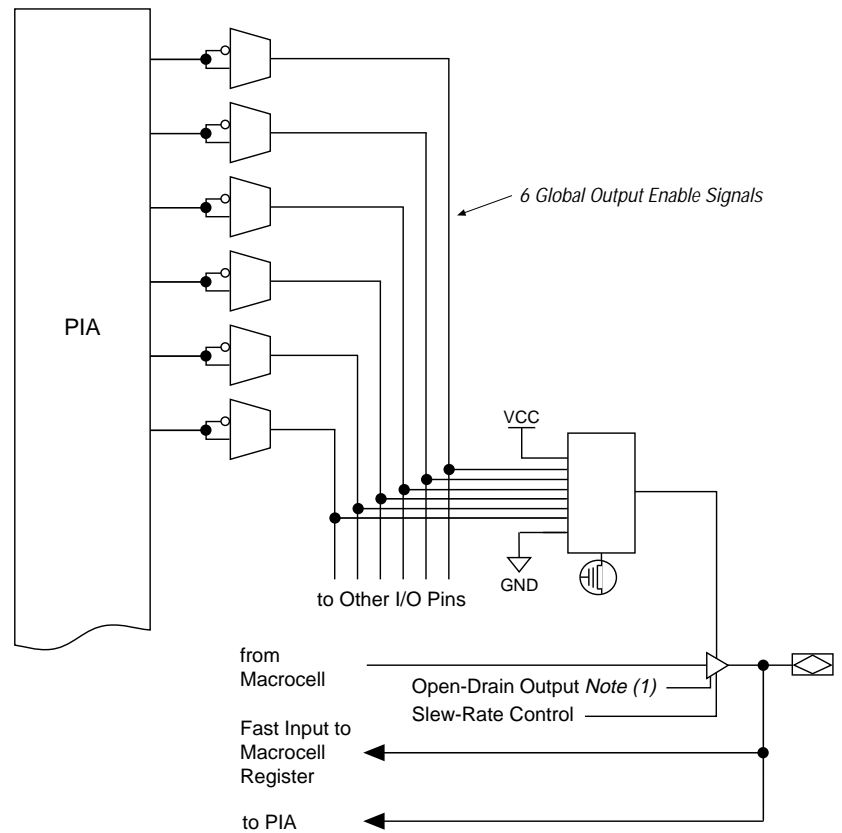

Note:

(1) The open-drain output option is available in MAX 7000S devices only.

When the tri-state buffer control is connected to GND, the output is tri-stated (high impedance) and the I/O pin can be used as a dedicated input. When the tri-state buffer control is connected to VCC, the output is enabled.

The MAX 7000 architecture provides dual I/O feedback, in which macrocell and pin feedbacks are independent. When an I/O pin is configured as an input, the associated macrocell can be used for buried logic.

In-System Programmability (ISP)

MAX 7000S devices are in-system programmable via an industry-standard 4-pin Joint Test Action Group (JTAG) interface (IEEE Std 1149.1-1990). ISP offers quick, efficient iterations during design development and debugging cycles. The MAX 7000S architecture internally generates the 12.0-V programming voltage required to program EEPROM cells, eliminating the need for an external 12.0-V power supply to program the devices on the board. During ISP, the I/O pins are tri-stated to eliminate board conflicts.

ISP simplifies the manufacturing flow by allowing the devices to be mounted on a printed circuit board with standard pick-and-place equipment before they are programmed. MAX 7000S devices can be programmed by downloading the information via automatic test equipment, embedded processors, or the Altera BitBlaster serial download cable. Programming the devices after they are placed on the board eliminates lead damage on high-pin-count packages (e.g., QFP packages) due to device handling. MAX 7000S devices can be reprogrammed after a system has already shipped to the field. For example, product upgrades can be performed in the field via software or modem.



Go to [Application Brief 145 \(Designing for In-System Programmability in MAX 7000S Devices\)](#) for more information.

ClockBoost

To support high-speed designs, specially marked MAX 7000S devices offer optional ClockBoost circuitry. This circuit is a phase-locked loop (PLL) and can be used to increase design speed and reduce resource usage. With the ClockBoost circuitry, which provides a clock multiplier, designers can easily implement time-domain-multiplexed logic to reduce resource usage in a design.

Programmable Speed/Power Control

MAX 7000 devices offer a power-saving mode that supports low-power operation across user-defined signal paths or the entire device. This feature allows total power dissipation to be reduced by 50% or more, because most logic applications require only a small fraction of all gates to operate at maximum frequency.

The designer can program each individual macrocell in a MAX 7000 device for either high-speed (Turbo Bit on) or low-power (Turbo Bit off) operation. As a result, speed-critical paths in the design can run at high speed, while the remaining paths can operate at reduced power. Macrocells that run at low power incur a nominal timing delay adder (t_{LPA}) for the t_{LAD} , t_{LAC} , t_{IC} , t_{ACL} , t_{EN} , and t_{SEXP} parameters.

Output Configuration

MAX 7000 device outputs can be programmed to meet a variety of system-level requirements.

3.3-V or 5.0-V I/O Operation

All MAX 7000 devices, except 44-pin devices, can be set for 3.3-V or 5.0-V I/O operation. These devices have two sets of V_{CC} pins: one set for internal operation and input buffers (V_{CCINT}) and another set for I/O output drivers (V_{CCIO}).

V_{CCINT} pins must always be connected to a 5.0-V power supply. With this V_{CCINT} level, input voltages are at TTL levels, and are compatible with both 3.3-V and 5.0-V inputs. V_{CCIO} pins can be connected to either a 3.3-V or a 5.0-V power supply, depending on the output requirements. When V_{CCIO} pins are connected to a 5.0-V supply, the output levels are compatible with 5.0-V systems. When they are connected to a 3.3-V supply, the output high is 3.3 V and is compatible with both 3.3-V and 5.0-V systems. Devices operating with V_{CCIO} levels lower than 4.75 V incur a nominal timing delay adder to the output buffer timing parameter (t_{OD}).

Open-Drain Output Option (MAX 7000S Devices Only)

MAX 7000S devices provide an optional open-drain (or equivalent open-collector) output for each I/O pin. This open-drain output enables the device to provide system-level control signals (e.g., interrupt and write enable signals) that can be asserted by any of several devices. It can also provide an additional wired-OR plane.

Slew-Rate Control

The output buffer for each MAX 7000E and MAX 7000S I/O pin has an adjustable output slew rate that can be configured for low-noise or high-speed performance. A faster slew rate provides high-speed transitions for high-performance systems. However, these fast transitions may introduce noise transients into the system. A slow slew rate reduces system noise, but adds a nominal delay of 4 to 5 ns. In MAX 7000E devices, when the Turbo Bit is turned off, the slew rate is set for low noise performance. For MAX 7000S devices, each I/O pin has an individual EEPROM bit that controls the slew rate, allowing designers to specify the slew rate on a pin-by-pin basis.

Programming with External Hardware

MAX 7000 devices can be programmed on 486- and Pentium-based PCs with an Altera Logic Programmer card, the Master Programming Unit (MPU), and the appropriate device adapter. The MPU performs continuity checking to ensure adequate electrical contact between the adapter and the device. For more information, see *Altera Programming Hardware* in this data book.

The MAX+PLUS II software can use text- or waveform-format test vectors created with the MAX+PLUS II Text or Waveform Editor to test the programmed device. For added design verification, designers can perform functional testing to compare the functional behavior of a MAX 7000 device with the results of simulation.

Data I/O and other programming hardware manufacturers also provide programming support for Altera devices. See *Programming Hardware Manufacturers* in this data book for more information.

JTAG Operation

MAX 7000S devices support JTAG BST circuitry as specified by IEEE Std 1149.1-1990. The EPM7128S, EPM7160S, EPM7192S, and EPM7256S devices support the following four JTAG modes: SAMPLE/PRELOAD, EXTEST, BYPASS, and IDCODE. The EPM7032S, EPM7064S, and EPM7096S devices support the IDCODE mode; these devices also support the BYPASS mode to ensure that JTAG chains are not interrupted. The pin-out tables starting on [page 235](#) of this data sheet show the location of the JTAG control pins for each device. If the JTAG interface is not required, the JTAG pins are available as user I/O pins.



Go to [Application Note 39 \(JTAG Boundary-Scan Testing in Altera Devices\)](#) for more information.

Design Security

All MAX 7000 devices contain a programmable security bit that controls access to the data programmed into the device. When this bit is programmed, a proprietary design implemented in the device cannot be copied or retrieved. This feature provides a high level of design security, because programmed data within EEPROM cells is invisible. The security bit that controls this function, as well as all other programmed data, is reset only when the device is reprogrammed.

Generic Testing

MAX 7000 devices are fully functionally tested. Complete testing of each programmable EEPROM bit and all internal logic elements ensures 100% programming yield. AC test measurements are taken under conditions equivalent to those shown in [Figure 9](#). Test patterns can be used and then erased during early stages of the production flow.

Figure 9. MAX 7000 AC Test Conditions

Power supply transients can affect AC measurements. Simultaneous transitions of multiple outputs should be avoided for accurate measurement. Threshold tests must not be performed under AC conditions. Large-amplitude, fast ground-current transients normally occur as the device outputs discharge the load capacitances. When these transients flow through the parasitic inductance between the device ground pin and the test system ground, significant reductions in observable noise immunity can result. Numbers in parentheses are for 3.3-V devices.

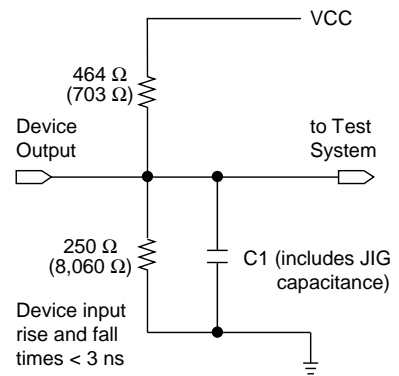

QFP Carrier & Development Socket

MAX 7000 and MAX 7000E devices in QFP packages with 100 or more pins are shipped in special plastic carriers to protect the fragile QFP leads. The carrier is used with a prototype development socket and special programming hardware available from Altera. This carrier technology makes it possible to program, test, erase, and reprogram a device without exposing the leads to mechanical stress. For detailed information and carrier dimensions, refer to the [QFP Carrier & Development Socket Data Sheet](#) in this data book.



MAX 7000S devices are not shipped in carriers.

MAX 7000 5.0-V Device Absolute Maximum Ratings Notes (1), (2)

Symbol	Parameter	Conditions	Min	Max	Unit
V _{CC}	Supply voltage	With respect to GND	-2.0	7.0	V
V _I	DC input voltage		Note (3)	-2.0	7.0
I _{OUT}	DC output current, per pin		-25	25	mA
T _{STG}	Storage temperature	No bias	-65	150	°C
T _{AMB}	Ambient temperature	Under bias	-65	135	°C
T _J	Junction temperature	Ceramic packages, under bias		150	°C
		Plastic and power quad flat pack packages, under bias		135	°C

MAX 7000 5.0-V Device Recommended Operating Conditions Note (2)

Symbol	Parameter	Conditions	Min	Max	Unit
V _{CCINT}	Supply voltage for internal logic and input buffers	Notes (4), (5)	4.75 (4.5)	5.25 (5.5)	V
V _{CCIO}	Supply voltage for output drivers, 5.0-V operation	Notes (4), (5)	4.75 (4.5)	5.25 (5.5)	V
	Supply voltage for output drivers, 3.3-V operation	Notes (5), (6)	3.00	3.60	V
V _{CCISP}	Supply voltage during ISP	Note (7)	4.75	5.25	V
V _I	Input voltage		0	V _{CCINT}	V
V _O	Output voltage		0	V _{CCIO}	V
T _A	Operating temperature	For commercial use	0	70	°C
T _A	Operating temperature	For industrial use	-40	85	°C
t _R	Input rise time			40	ns
t _F	Input fall time			40	ns

MAX 7000 5.0-V Device DC Operating Conditions Notes (2), (8)

Symbol	Parameter	Conditions	Min	Max	Unit
V _{IH}	High-level input voltage		2.0	V _{CCINT} + 0.3	V
V _{IL}	Low-level input voltage		-0.3	0.8	V
V _{OH}	5.0-V high-level TTL output voltage	I _{OH} = -4 mA DC, V _{CCIO} = 4.75 V, Note (9)	2.4		V
	3.3-V high-level TTL output voltage	I _{OH} = -4 mA DC, V _{CCIO} = 3.0 V, Note (9)	2.4		V
V _{OL}	5.0-V low-level TTL output voltage	I _{OL} = 12 mA DC, V _{CCIO} = 4.75 V, Note (10)		0.45	V
	3.3-V low-level TTL output voltage	I _{OL} = 12 mA DC, V _{CCIO} = 3.0 V, Note (10)		0.45	V
I _I	Input leakage current	V _I = V _{CC} or GND	-10	10	μA
I _{OZ}	Tri-state output off-state current	V _O = V _{CC} or GND	-40	40	μA

MAX 7000 5.0-V Device Capacitance: EPM7032, EPM7064 & EPM7096 *Note (11)*

Symbol	Parameter	Conditions	Min	Max	Unit
C _{IN}	Input pin capacitance	V _{IN} = 0 V, f = 1.0 MHz		12	pF
C _{I/O}	I/O pin capacitance	V _{OUT} = 0 V, f = 1.0 MHz		12	pF

MAX 7000 5.0-V Device Capacitance: MAX 7000E *Note (11)*

Symbol	Parameter	Conditions	Min	Max	Unit
C _{IN}	Input pin capacitance	V _{IN} = 0 V, f = 1.0 MHz		15	pF
C _{I/O}	I/O pin capacitance	V _{OUT} = 0 V, f = 1.0 MHz		15	pF

MAX 7000 5.0-V Device Capacitance: MAX 7000S *Notes (2), (11), (12)*

Symbol	Parameter	Conditions	Min	Max	Unit
C _{IN}	Input pin capacitance	V _{IN} = 0 V, f = 1.0 MHz		10	pF
C _{I/O}	I/O pin capacitance	V _{OUT} = 0 V, f = 1.0 MHz		10	pF

Notes to tables:

- (1) See *Operating Requirements for Altera Devices Data Sheet* in this data book.
- (2) Information on MAX 7000S devices is preliminary.
- (3) Minimum DC input is -0.3 V. During transitions, the inputs may undershoot to -2.0 V or overshoot to 7.0 V for periods shorter than 20 ns under no-load conditions.
- (4) Numbers in parentheses are for industrial-temperature-range versions.
- (5) V_{CC} must rise monotonically.
- (6) 3.3-V I/O operation is not available for 44-pin packages.
- (7) The V_{CCISP} parameter applies only to MAX 7000S devices.
- (8) Operating conditions: V_{CCINT} = 5.0 V ± 5%, T_A = 0° C to 70° C for commercial use.
V_{CCINT} = 5.0 V ± 10%, T_A = -40° C to 85° C for industrial use.
- (9) The I_{OH} parameter refers to high-level TTL output current.
- (10) The I_{OL} parameter refers to low-level TTL output current.
- (11) Capacitance is measured at 25° C and is sample-tested only. The OE1 pin (high-voltage pin during programming) has a maximum capacitance of 20 pF.
- (12) When the JTAG interface is enabled in MAX 7000S devices, the input leakage current on the JTAG pins is typically -60 μA.

Figure 10 shows the typical output drive characteristics of MAX 7000 devices.

Figure 10. Output Drive Characteristics of 5.0-V MAX 7000 Devices

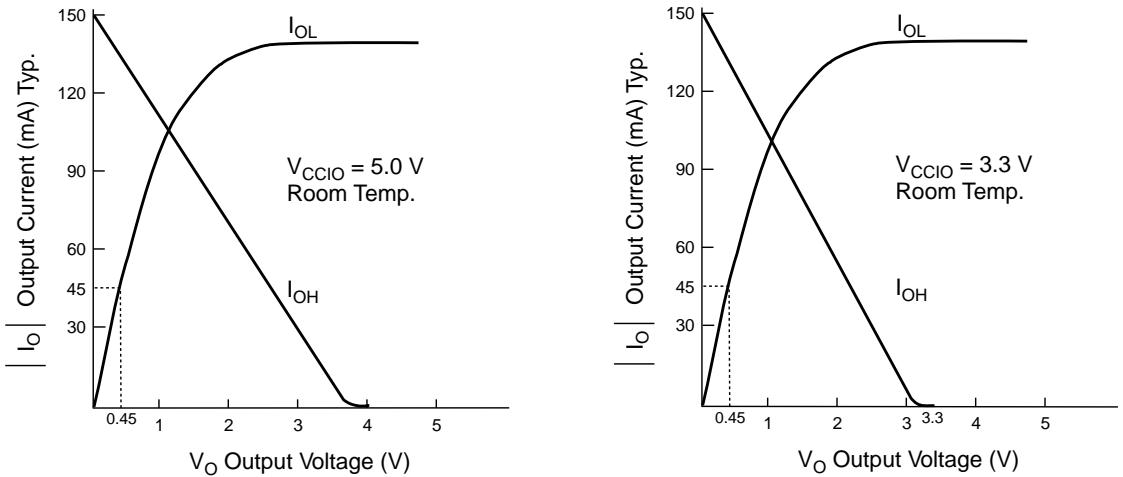

3.3-V EPM7032V

The EPM7032V device is a high-performance MAX 7000 device that meets the low power and voltage requirements of 3.3-V applications ranging from notebook computers to battery-operated, hand-held equipment. The EPM7032V provides in-system speeds of up to 90.9 MHz and propagation delays of 12 ns. It is available in 44-pin reprogrammable PLCC or TQFP packages and can accommodate designs with up to 36 inputs and 32 outputs.

Power Management

The 3.3-V operation of the EPM7032V offers power savings of 30% to 50% over the 5.0-V operation of the EPM7032. Power-saving features of the EPM7032V include the programmable speed/power control as specified for non-3.3-V MAX 7000 devices and a power-down mode.

Power-Down Mode

The EPM7032V device provides a unique power-down mode that allows the device to consume near-zero power (typically 50 μ A). The power-down mode is controlled externally by the dedicated power-down pin (PDn). When PDn is asserted (active low), the power-down sequence latches all input pins, internal logic, and output pins of the EPM7032V device, preserving their present state. Output pins maintain their present low, high, or tri-state value while in power-down mode.

Once in power-down mode, any or all of the inputs, including clocks, can be toggled without affecting the state of the device. Because internal latches are used to ensure that the proper state exists during power-down mode, the external inputs and clocks must meet certain setup and hold time requirements. See Figure 11 and the “Power-Down Timing Parameters” and “Chip-Enable Timing Parameters” tables on page 229 of this data sheet.

Figure 11. Power-Down Mode Switching Waveforms

The switching waveforms for the EPM7032V are identical to those of the 5.0-V EPM7032 in all modes, except for the additional power-down mode shown here. t_R & $t_F < 3$ ns. Inputs are driven at 3 V for a logic high and 0 V for a logic low. All timing characteristics are measured at 1.5 V.

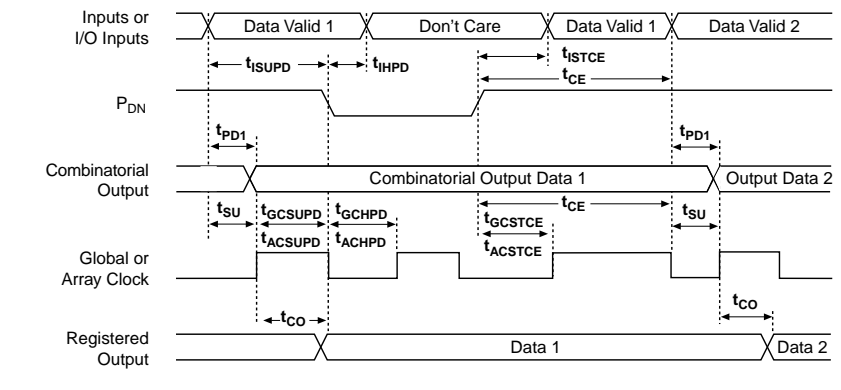

When the PDn signal is brought high, the device is enabled and the combinatorial outputs respond to the present input conditions within the specified chip enable delay (t_{CE}). Registered outputs respond to clock transitions within t_{CE} . Clocking the device during the chip enable sequence can cause the data to change inside the chip if a clock transition occurs during certain intervals of the chip enable or chip disable sequences. All clocks should be gated to prevent clock transitions during the clock setup time (t_{GCSUPD} or t_{ACSUPD}) and during the chip enable setup time (t_{GCSTCE} or t_{ACSTCE}), as shown in Figure 11.

All registers in the EPM7032V provide clock enable control, which makes it easy to disable clocks. If output signals must be frozen in a high-impedance state during power-down, the associated output enable signal must be asserted, the system clock must be removed, and the PDn pin must be asserted. To reactivate the device, the sequence is reversed. For some systems, it may be more appropriate to switch the order of the clock and output enable controls.

All power-down / chip-enable timing parameters are computed from external input or I/O pins, with the macrocell Turbo Bit turned on, and without the use of parallel expanders. For macrocells in low-power mode (Turbo Bit off), the low-power adder, t_{LPA} , must be added to the power-down / chip enable timing parameters, which include the data paths t_{LAD} , t_{LAC} , t_{IC} , t_{ACL} , t_{ACH} , and t_{SEXP} . For macrocells that use shared or parallel expanders, t_{SEXP} or t_{PEXP} must be added. For data or clock paths that use more than one logic array delay, the worst-case data or clock delay must be added to the respective power-down / chip-enable parameters. Actual worst-case timing of data and clock paths can be calculated with the MAX+PLUS II Simulator or Timing Analyzer, or with other industry-standard EDA verification tools.

MAX 7000 3.3-V Device Absolute Maximum Ratings *Note (1)*

Symbol	Parameter	Conditions	Min	Max	Unit
V_{CC}	Supply voltage	With respect to GND, <i>Note (2)</i>	-2.0	5.6	V
V_I	DC input voltage	With respect to GND, <i>Note (2)</i>	-2.0	5.6	V
I_{OUT}	DC output current per pin		-25	25	mA
T_{STG}	Storage temperature	No bias	-65	150	°C
T_{AMB}	Ambient temperature	Under bias	-65	135	°C
T_J	Junction temperature	Under bias		135	°C
P_D	Power dissipation			1,000	mW
I_{MAX}	DC V_{CC} or GND current			300	mA

MAX 7000 3.3-V Device Recommended Operating Conditions

Symbol	Parameter	Conditions	Min	Max	Unit
V_{CC}	Supply voltage	<i>Note (3)</i>	3.0	3.6	V
V_I	Input voltage		0	V_{CC}	V
V_O	Output voltage		0	V_{CC}	V
T_A	Operating temperature	For commercial use	0	70	°C
T_A	Operating temperature	For industrial use	-40	85	°C
t_R	Input rise time			40	ns
t_F	Input fall time			40	ns

MAX 7000 3.3-V Device DC Operating Conditions Notes (4), (5)

Symbol	Parameter	Conditions	Min	Typ	Max	Unit
V_{IH}	High-level input voltage		2.0		$V_{CC} + 0.3$	V
V_{IL}	Low-level input voltage		-0.3		0.8	V
V_{OH}	High-level TTL output voltage	$I_{OH} = -0.1$ mA DC, Note (6)	$V_{CC} - 0.2$			V
V_{OL}	Low-level output voltage	$I_{OL} = 4$ mA DC, Note (7)			0.45	V
I_I	Input leakage current	$V_I = V_{CC}$ or GND	-10		10	μ A
I_{OZ}	Tri-state output off-state current	$V_O = V_{CC}$ or GND	-10		10	μ A
I_{CC0}	V_{CC} supply current (standby, power-down mode)	Note (8)		2	150	μ A
I_{CC1}	V_{CC} supply current (standby, low-power mode)	$V_I =$ GND, no load, Note (8)		10	20	mA
I_{CC2}	V_{CC} supply current (active, low-power mode)	$V_I =$ GND, no load, $f = 1.0$ MHz, Note (8)		15	25	mA

MAX 7000 3.3-V Device Capacitance Note (9)

Symbol	Parameter	Conditions	Min	Max	Unit
C_{IN}	Input capacitance	$V_{IN} = 0$ V, $f = 1.0$ MHz		12	pF
C_{OUT}	Output capacitance	$V_{OUT} = 0$ V, $f = 1.0$ MHz		12	pF

Notes to tables:

- See the *Operating Requirements for Altera Devices Data Sheet* in this data book.
- Minimum DC input is -0.3 V. During transitions, the inputs may undershoot to -2.0 V or overshoot to $V_{CC} + 2.0$ V for periods shorter than 20 ns under no-load conditions.
- V_{CC} must rise monotonically.
- Typical values are for $T_A = 25^\circ$ C and $V_{CC} = 3.3$ V.
- Operating conditions: $V_{CC} = 3.3$ V \pm 10%, $T_A = 0^\circ$ C to 70° C for commercial use.
 $V_{CC} = 3.3$ V \pm 10%, $T_A = -40^\circ$ C to 85° C for industrial use.
- The I_{OH} parameter refers to high-level TTL output current.
- The I_{OL} parameter refers to low-level TTL output current.
- Measured with a 16-bit loadable, enabled, up/down counter programmed into each LAB. I_{CC} is measured at 0° C.
- Capacitance is measured at 25° C and is sample-tested only. The OE1 pin (high-voltage pin during programming) has a maximum capacitance of 20 pF.

Figure 12 shows the typical output drive characteristics of the EPM7032V.

Figure 12. EPM7032V Output Drive Characteristics

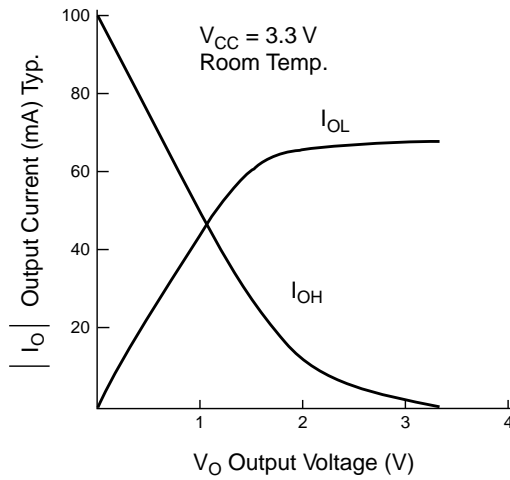

Timing Model

MAX 7000 device timing can be analyzed with the MAX+PLUS II software, with a variety of popular industry-standard EDA simulators and timing analyzers, or with the timing model shown in Figure 13. MAX 7000 devices have fixed internal delays that enable the designer to determine the worst-case timing of any design. MAX+PLUS II software provides timing simulation, point-to-point delay prediction, and detailed timing analysis for device-wide performance evaluation.

Figure 13. MAX 7000 Timing Model

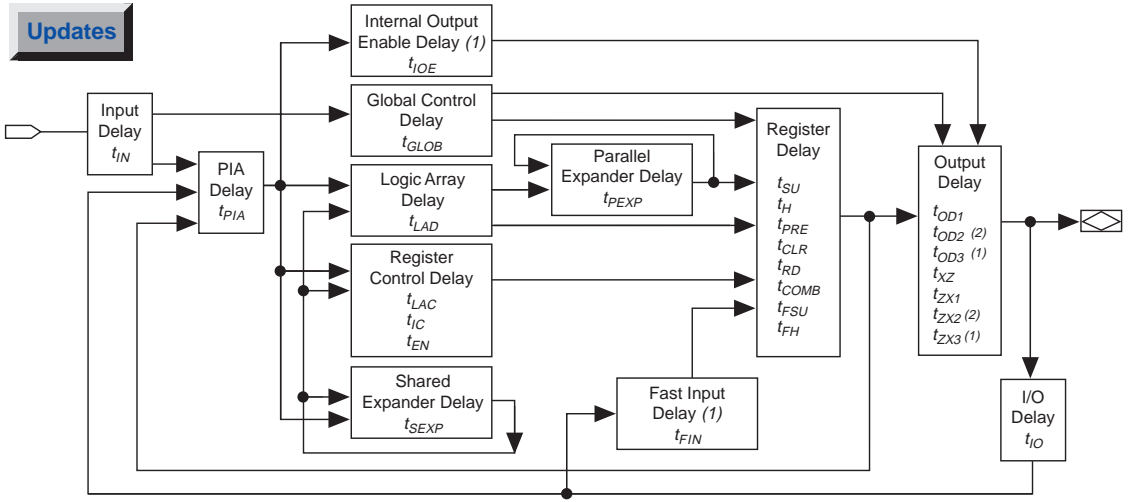

Notes:

- (1) Not available in 44-pin devices.
- (2) Only available in MAX 7000E and MAX 7000S devices.

The timing characteristics of any signal path can be derived from the timing model and parameters of a particular device. External timing parameters, which represent pin-to-pin timing delays, can be calculated as the sum of internal parameters. Figure 14 shows the internal timing relationship of internal and external delay parameters.



See [Application Note 78 \(Understanding MAX 7000, MAX 5000 & Classic Timing\)](#) in this data book for more information.

Figure 14. Switching Waveforms

t_R & $t_F < 3$ ns.
 Inputs are driven at 3 V
 for a logic high and 0 V
 for a logic low. All timing
 characteristics are
 measured at 1.5 V.

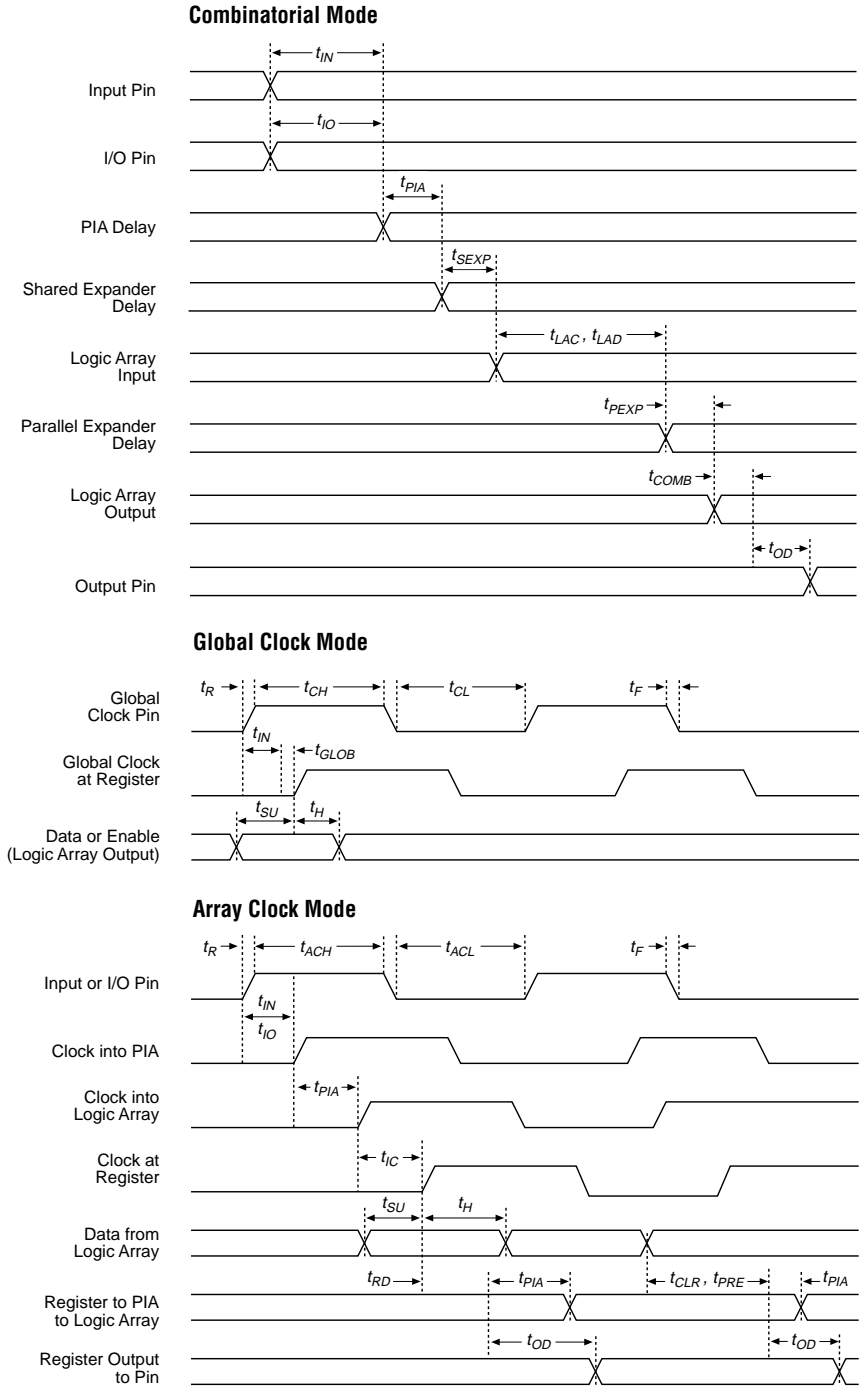

MAX 7000 AC Operating Conditions *Notes (1), (2)*

External Timing Parameters			Speed Grade						Unit
			-5		-6		-7		
Symbol	Parameter	Conditions	Min	Max	Min	Max	Min	Max	
t _{PD1}	Input to non-registered output	C1 = 35 pF		5		6		7.5	ns
t _{PD2}	I/O input to non-registered output	C1 = 35 pF		5		6		7.5	ns
t _{SU}	Global clock setup time		4		5		6		ns
t _H	Global clock hold time		0		0		0		ns
t _{FSU}	Global clock setup time of fast input	<i>Note (3)</i>	–		–		3		ns
t _{FH}	Global clock hold time of fast input	<i>Note (3)</i>	–		–		0.5		ns
t _{CO1}	Global clock to output delay	C1 = 35 pF		3.5		4		4.5	ns
t _{CH}	Global clock high time		2		2.5		3		ns
t _{CL}	Global clock low time		2		2.5		3		ns
t _{ASU}	Array clock setup time		2		2.5		3		ns
t _{AH}	Array clock hold time		2		2		2		ns
t _{ACO1}	Array clock to output delay	C1 = 35 pF		5.5		6.5		7.5	ns
t _{ACH}	Array clock high time		2.5		3		3		ns
t _{ACL}	Array clock low time		2.5		3		3		ns
t _{ODH}	Output data hold time after clock	C1 = 35 pF, <i>Note (4)</i>	1		1		1		ns
t _{CNT}	Minimum global clock period			5.6		6.6		8	ns
f _{CNT}	Maximum internal global clock frequency	<i>Note (5)</i>	178.6		151.5		125		MHz
t _{ACNT}	Minimum array clock period			5.6		6.6		8	ns
f _{ACNT}	Maximum internal array clock frequency	<i>Note (5)</i>	178.6		151.5		125		MHz
f _{MAX}	Maximum clock frequency	<i>Note (6)</i>	250		200		166.7		MHz

Internal Timing Parameters			Speed Grade						Unit
			-5		-6		-7		
Symbol	Parameter	Conditions	Min	Max	Min	Max	Min	Max	Unit
t_{IN}	Input pad and buffer delay			0.4		0.4		0.5	ns
t_{IO}	I/O input pad and buffer delay			0.4		0.4		0.5	ns
t_{FIN}	Fast input delay	Note (3)						1	ns
t_{SEXP}	Shared expander delay			3		3.5		4	ns
t_{PEXP}	Parallel expander delay			0.8		0.8		0.8	ns
t_{LAD}	Logic array delay			1.5		2		3	ns
t_{LAC}	Logic control array delay			1.5		2		3	ns
t_{IOE}	Internal output enable delay	Note (3)						2	ns
t_{OD1}	Output buffer & pad delay Slow slew rate = off $V_{CCIO} = 5.0\text{ V}$	$C1 = 35\text{ pF}$ Note (1)		1.5		2		2	ns
t_{OD2}	Output buffer & pad delay Slow slew rate = off $V_{CCIO} = 3.3\text{ V}$	$C1 = 35\text{ pF}$ Note (7)		2.0		2.5		2.5	ns
t_{OD3}	Output buffer & pad delay Slow slew rate = on $V_{CCIO} = 5.0\text{ V}$ or 3.3 V	$C1 = 35\text{ pF}$ Notes (1), (3), (7)		6.5		7		7	ns
t_{ZX1}	Output buffer enable delay Slow slew rate = off $V_{CCIO} = 5.0\text{ V}$	$C1 = 35\text{ pF}$ Note (7)		4		4		4	ns
t_{ZX2}	Output buffer enable delay Slow slew rate = off $V_{CCIO} = 3.3\text{ V}$	$C1 = 35\text{ pF}$ Note (7)		–		4.5		4.5	ns
t_{ZX3}	Output buffer enable delay Slow slew rate = on $V_{CCIO} = 5.0\text{ V}$ or 3.3 V	$C1 = 35\text{ pF}$ Note (7)		–		–		9	ns
t_{XZ}	Output buffer disable delay	$C1 = 5\text{ pF}$		4		4		4	ns
t_{SU}	Register setup time		2.5		3		3		ns
t_H	Register hold time		1.5		1.5		2		ns
t_{FSU}	Register setup time of fast input	Note (3)					3		ns
t_{FH}	Register hold time of fast input	Note (3)					0.5		ns
t_{RD}	Register delay			0.8		0.8		1	ns
t_{COMB}	Combinatorial delay			0.8		0.8		1	ns
t_{IC}	Array clock delay			2		2.5		3	ns
t_{EN}	Register enable time			1.5		2		3	ns
t_{GLOB}	Global control delay			0.8		0.8		1	ns
t_{PRE}	Register preset time			2		2		2	ns
t_{CLR}	Register clear time			2		2		2	ns
t_{PIA}	PIA delay			0.8		0.8		1	ns
t_{LPA}	Low-power adder	Note (8)		8		10		10	ns

External Timing Parameters 			Speed Grade				Unit
			MAX 7000E (-10P) MAX 7000S (-10)		MAX 7000 (-10) MAX 7000E (-10)		
Symbol	Parameter	Conditions	Min	Max	Min	Max	Unit
t_{PD1}	Input to non-registered output	C1 = 35 pF		10		10	ns
t_{PD2}	I/O input to non-registered output	C1 = 35 pF		10		10	ns
t_{SU}	Global clock setup time		7		8		ns
t_H	Global clock hold time		0		0		ns
t_{FSU}	Global clock setup time of fast input	Note (3)	3		3		ns
t_{FH}	Global clock hold time of fast input	Note (3)	0.5		0.5		ns
t_{CO1}	Global clock to output delay	C1 = 35 pF		5		5	ns
t_{CH}	Global clock high time		4		4		ns
t_{CL}	Global clock low time		4		4		ns
t_{ASU}	Array clock setup time		2		3		ns
t_{AH}	Array clock hold time		3		3		ns
t_{ACO1}	Array clock to output delay	C1 = 35 pF		10		10	ns
t_{ACH}	Array clock high time		4		4		ns
t_{ACL}	Array clock low time		4		4		ns
t_{ODH}	Output data hold time after clock	C1 = 35 pF, Note (4)	1		1		ns
t_{CNT}	Minimum global clock period			10		10	ns
f_{CNT}	Maximum internal global clock frequency	Note (8)	100		100		MHz
t_{ACNT}	Minimum array clock period			10		10	ns
f_{ACNT}	Maximum internal array clock frequency	Note (8)	100		100		MHz
f_{MAX}	Maximum clock frequency	Note (6)	125		125		MHz

Internal Timing Parameters			Speed Grade				Unit
			MAX 7000E (-10P) MAX 7000S (-10)		MAX 7000 (-10) MAX 7000E (-10)		
Symbol	Parameter	Conditions	Min	Max	Min	Max	Unit
t_{IN}	Input pad and buffer delay			0.5		1	ns
t_{IO}	I/O input pad and buffer delay			0.5		1	ns
t_{FIN}	Fast input delay	<i>Note (3)</i>		1		1	ns
t_{SEXP}	Shared expander delay			5		5	ns
t_{PEXP}	Parallel expander delay			0.8		0.8	ns
t_{LAD}	Logic array delay			5		5	ns
t_{LAC}	Logic control array delay			5		5	ns
t_{IOE}	Internal output enable delay	<i>Note (3)</i>		2		2	ns
t_{OD1}	Output buffer & pad delay Slow slew rate = off $V_{CCIO} = 5.0\text{ V}$	$C1 = 35\text{ pF}$, <i>Note (1)</i>		1.5		2	ns
t_{OD2}	Output buffer & pad delay Slow slew rate = off $V_{CCIO} = 3.3\text{ V}$	$C1 = 35\text{ pF}$, <i>Note (7)</i>		2		2.5	ns
t_{OD3}	Output buffer & pad delay Slow slew rate = on $V_{CCIO} = 5.0\text{ V}$ or 3.3 V	$C1 = 35\text{ pF}$, <i>Notes (1), (3), (7)</i>		5.5		6	ns
t_{ZX1}	Output buffer enable delay Slow slew rate = off $V_{CCIO} = 5.0\text{ V}$	$C1 = 35\text{ pF}$, <i>Note (7)</i>		5		5	ns
t_{ZX2}	Output buffer enable delay Slow slew rate = off $V_{CCIO} = 3.3\text{ V}$	$C1 = 35\text{ pF}$, <i>Note (7)</i>		5.5		5.5	ns
t_{ZX3}	Output buffer enable delay Slow slew rate = on $V_{CCIO} = 5.0\text{ V}$ or 3.3 V	$C1 = 35\text{ pF}$, <i>Note (7)</i>		9		9	ns
t_{XZ}	Output buffer disable delay	$C1 = 5\text{ pF}$		5		5	ns
t_{SU}	Register setup time		2		3		ns
t_H	Register hold time		3		3		ns
t_{FSU}	Register setup time of fast input	<i>Note (3)</i>	3		3		ns
t_{FH}	Register hold time of fast input	<i>Note (3)</i>	0.5		0.5		ns
t_{RD}	Register delay			2		1	ns
t_{COMB}	Combinatorial delay			2		1	ns
t_{IC}	Array clock delay			5		5	ns
t_{EN}	Register enable time			5		5	ns
t_{GLOB}	Global control delay			1		1	ns
t_{PRE}	Register preset time			3		3	ns
t_{CLR}	Register clear time			3		3	ns
t_{PIA}	PIA delay			1		1	ns
t_{LPA}	Low-power adder	<i>Note (8)</i>		11		11	ns

External Timing Parameters 			Speed Grade				Unit
			MAX 7000E (-12P)		MAX 7000 (-12) MAX 7000E (-12)		
Symbol	Parameter	Conditions	Min	Max	Min	Max	Unit
t_{PD1}	Input to non-registered output	C1 = 35 pF		12		12	ns
t_{PD2}	I/O input to non-registered output	C1 = 35 pF		12		12	ns
t_{SU}	Global clock setup time		7		10		ns
t_H	Global clock hold time		0		0		ns
t_{FSU}	Global clock setup time of fast input	Note (3)	3		3		ns
t_{FH}	Global clock hold time of fast input	Note (3)	1		1		ns
t_{CO1}	Global clock to output delay	C1 = 35 pF		6		6	ns
t_{CH}	Global clock high time		4		4		ns
t_{CL}	Global clock low time		4		4		ns
t_{ASU}	Array clock setup time		3		4		ns
t_{AH}	Array clock hold time		4		4		ns
t_{ACO1}	Array clock to output delay	C1 = 35 pF		12		12	ns
t_{ACH}	Array clock high time		5		5		ns
t_{ACL}	Array clock low time		5		5		ns
t_{ODH}	Output data hold time after clock	C1 = 35 pF, Note (4)	1		1		ns
t_{CNT}	Minimum global clock period			11		11	ns
f_{CNT}	Maximum internal global clock frequency	Note (8)	90.9		90.9		MHz
t_{ACNT}	Minimum array clock period			11		11	ns
f_{ACNT}	Maximum internal array clock frequency	Note (8)	90.9		90.9		MHz
f_{MAX}	Maximum clock frequency	Note (6)	125		125		MHz

Internal Timing Parameters			Speed Grade				Unit
			MAX 7000E (-12P)		MAX 7000 (-12) MAX 7000E (-12)		
Symbol	Parameter	Conditions	Min	Max	Min	Max	Unit
t_{IN}	Input pad and buffer delay			1		2	ns
t_{IO}	I/O input pad and buffer delay			1		2	ns
t_{FIN}	Fast input delay	Note (3)		1		1	ns
t_{SEXP}	Shared expander delay			7		7	ns
t_{PEXP}	Parallel expander delay			1		1	ns
t_{LAD}	Logic array delay			7		5	ns
t_{LAC}	Logic control array delay			5		5	ns
t_{IOE}	Internal output enable delay	Note (3)		2		2	ns
t_{OD1}	Output buffer & pad delay Slow slew rate = off $V_{CCIO} = 5.0\text{ V}$	$C1 = 35\text{ pF}$, Note (1)		1		3	ns
t_{OD2}	Output buffer & pad delay Slow slew rate = off $V_{CCIO} = 3.3\text{ V}$	$C1 = 35\text{ pF}$, Note (7)		2		4	ns
t_{OD3}	Output buffer & pad delay Slow slew rate = on $V_{CCIO} = 5.0\text{ V}$ or 3.3 V	$C1 = 35\text{ pF}$, Notes (1), (3), (7)		5		7	ns
t_{ZX1}	Output buffer enable delay Slow slew rate = off $V_{CCIO} = 5.0\text{ V}$	$C1 = 35\text{ pF}$, Note (7)		6		6	ns
t_{ZX2}	Output buffer enable delay Slow slew rate = off $V_{CCIO} = 3.3\text{ V}$	$C1 = 35\text{ pF}$, Note (7)		7		7	ns
t_{ZX3}	Output buffer enable delay Slow slew rate = on $V_{CCIO} = 5.0\text{ V}$ or 3.3 V	$C1 = 35\text{ pF}$, Note (7)		10		10	ns
t_{XZ}	Output buffer disable delay	$C1 = 5\text{ pF}$		6		6	ns
t_{SU}	Register setup time		1		4		ns
t_H	Register hold time		6		4		ns
t_{FSU}	Register setup time of fast input	Note (3)	4		2		ns
t_{FH}	Register hold time of fast input	Note (3)	0		2		ns
t_{RD}	Register delay			2		1	ns
t_{COMB}	Combinatorial delay			2		1	ns
t_{IC}	Array clock delay			5		5	ns
t_{EN}	Register enable time			7		5	ns
t_{GLOB}	Global control delay			2		0	ns
t_{PRE}	Register preset time			4		3	ns
t_{CLR}	Register clear time			4		3	ns
t_{PIA}	PIA delay			1		1	ns
t_{LPA}	Low-power adder	Note (8)		12		12	ns

External Timing Parameters 			Speed Grade						Unit
			-15		-15T		-20		
Symbol	Parameter	Conditions	Min	Max	Min	Max	Min	Max	
t_{PD1}	Input to non-registered output	$C1 = 35 \text{ pF}$		15		15		20	ns
t_{PD2}	I/O input to non-registered output	$C1 = 35 \text{ pF}$		15		15		20	ns
t_{SU}	Global clock setup time		11		11		12		ns
t_H	Global clock hold time		0		0		0		ns
t_{FSU}	Global clock setup time of fast input	Note (3)	3		–		5		ns
t_{FH}	Global clock hold time of fast input	Note (3)	1		–		2		ns
t_{CO1}	Global clock to output delay	$C1 = 35 \text{ pF}$		8		8		12	ns
t_{CH}	Global clock high time		5		6		6		ns
t_{CL}	Global clock low time		5		6		6		ns
t_{ASU}	Array clock setup time		4		4		5		ns
t_{AH}	Array clock hold time		4		4		5		ns
t_{ACO1}	Array clock to output delay	$C1 = 35 \text{ pF}$		15		15		20	ns
t_{ACH}	Array clock high time		6		6.5		8		ns
t_{ACL}	Array clock low time		6		6.5		8		ns
t_{ODH}	Output data hold time after clock	$C1 = 35 \text{ pF}$, Note (4)	1		1		1		ns
t_{CNT}	Minimum global clock period			13		13		16	ns
f_{CNT}	Maximum internal global clock frequency	Note (8)	76.9		76.9		62.5		MHz
t_{ACNT}	Minimum array clock period			13		13		16	ns
f_{ACNT}	Maximum internal array clock frequency	Note (8)	76.9		76.9		62.5		MHz
f_{MAX}	Maximum clock frequency	Note (6)	100		83.3		83.3		MHz

Internal Timing Parameters			Speed Grade						Unit
			-15		-15T		-20		
Symbol	Parameter	Conditions	Min	Max	Min	Max	Min	Max	Unit
t_{IN}	Input pad and buffer delay			2		2		3	ns
t_{IO}	I/O input pad and buffer delay			2		2		3	ns
t_{FIN}	Fast input delay	Note (3)		2		–		4	ns
t_{SEXP}	Shared expander delay			8		10		9	ns
t_{PEXP}	Parallel expander delay			1		1		2	ns
t_{LAD}	Logic array delay			6		6		8	ns
t_{LAC}	Logic control array delay			6		6		8	ns
t_{IOE}	Internal output enable delay	Note (3)		3		–		4	ns
t_{OD1}	Output buffer & pad delay Slow slew rate = off $V_{CCIO} = 5.0\text{ V}$	$C1 = 35\text{ pF}$, Note (1)		4		4		5	ns
t_{OD2}	Output buffer & pad delay Slow slew rate = off $V_{CCIO} = 3.3\text{ V}$	$C1 = 35\text{ pF}$, Note (7)		5		–		6	ns
t_{OD3}	Output buffer & pad delay Slow slew rate = on $V_{CCIO} = 5.0\text{ V}$ or 3.3 V	$C1 = 35\text{ pF}$, Notes (3), (7)		8		–		9	ns
t_{ZX1}	Output buffer enable delay Slow slew rate = off $V_{CCIO} = 5.0\text{ V}$	$C1 = 35\text{ pF}$, Note (7)		6		6		10	ns
t_{ZX2}	Output buffer enable delay Slow slew rate = off $V_{CCIO} = 3.3\text{ V}$	$C1 = 35\text{ pF}$, Note (7)		7		–		11	ns
t_{ZX3}	Output buffer enable delay Slow slew rate = on $V_{CCIO} = 5.0\text{ V}$ or 3.3 V	$C1 = 35\text{ pF}$, Note (7)		10		–		14	ns
t_{XZ}	Output buffer disable delay	$C1 = 5\text{ pF}$		6		6		10	ns
t_{SU}	Register setup time		4		4		4		ns
t_H	Register hold time		4		4		5		ns
t_{FSU}	Register setup time of fast input	Note (3)	2		–		4		ns
t_{FH}	Register hold time of fast input	Note (3)	2		–		3		ns
t_{RD}	Register delay			1		1		1	ns
t_{COMB}	Combinatorial delay			1		1		1	ns
t_{IC}	Array clock delay			6		6		8	ns
t_{EN}	Register enable time			6		6		8	ns
t_{GLOB}	Global control delay			1		1		3	ns
t_{PRE}	Register preset time			4		4		4	ns
t_{CLR}	Register clear time			4		4		4	ns
t_{PIA}	PIA delay			2		2		3	ns
t_{LPA}	Low-power adder	Note (8)		13		15		15	ns

Notes to tables:

- (1) Operating conditions:
 $V_{CCINT} = 5.0\text{ V} \pm 5\%$, $V_{CCIO} = 5.0\text{ V} \pm 5\%$ (except where noted), $T_A = 0^\circ\text{ C}$ to 70° C for commercial use.
 $V_{CCINT} = 5.0\text{ V} \pm 10\%$, $V_{CCIO} = 5.0\text{ V} \pm 10\%$ (except where noted), $T_A = -40^\circ\text{ C}$ to 85° C for industrial use.
- (2) Timing parameters for some devices are preliminary. See [Table 2 on page 193](#) of this data sheet for available speed grades and [Table 4 on page 195](#) for available packages.
- (3) This parameter applies only to MAX 7000E and MAX 7000S devices.
- (4) This parameter is a guideline that is sample-tested only and is based on extensive device characterization. This parameter applies for both global and array clocking.
- (5) Measured with a 16-bit loadable, enabled, up/down counter programmed into each LAB.
- (6) The f_{MAX} values represent the highest frequency for pipelined data.
- (7) Operating conditions: $V_{CCIO} = 3.3\text{ V} \pm 10\%$ for commercial and industrial use.
- (8) The t_{LPA} parameter must be added to the t_{LAD} , t_{LAC} , t_{IC} , t_{ACL} , t_{EN} , and t_{SEXP} parameters for macrocells running in the low-power mode.

EPM7032V AC Operating Conditions *Note (1)*

External Timing Parameters			EPM7032V-12		EPM7032V-15		EPM7032V-20		
Symbol	Parameter	Conditions	Min	Max	Min	Max	Min	Max	Unit
t_{PD1}	Input to non-registered output	C1 = 35 pF		12		15		20	ns
t_{PD2}	I/O input to non-registered output	C1 = 35 pF		12		15		20	ns
t_{SU}	Global clock setup time		10		11		12		ns
t_H	Global clock hold time		0		0		0		ns
t_{CO1}	Global clock to output delay	C1 = 35 pF		7		8		12	ns
t_{CH}	Global clock high time		4		5		6		ns
t_{CL}	Global clock low time		4		5		6		ns
t_{ASU}	Array clock setup time		4		4		5		ns
t_{AH}	Array clock hold time		4		4		5		ns
t_{ACO1}	Array clock to output delay	C1 = 35 pF		12		15		20	ns
t_{ACH}	Array clock high time		5		6		8		ns
t_{ACL}	Array clock low time		5		6		8		ns
t_{ODH}	Output data hold time after clock	C1 = 35 pF, <i>Note (2)</i>	1		1		1		ns
t_{CNT}	Minimum global clock period			11		13		16	ns
f_{CNT}	Maximum internal global clock frequency	<i>Note (3)</i>	90.9		76.9		62.5		MHz
t_{ACNT}	Minimum array clock period			11		13		16	ns
f_{ACNT}	Maximum internal array clock frequency	<i>Note (3)</i>	90.9		76.9		62.5		MHz
f_{MAX}	Maximum clock frequency	<i>Note (4)</i>	125		100		83.3		MHz

EPM7032V AC Operating Conditions *Note (1)*

<i>Internal Timing Parameters</i>			EPM7032V-12		EPM7032V-15		EPM7032V-20		
Symbol	Parameter	Conditions	Min	Max	Min	Max	Min	Max	Unit
t_{IN}	Input pad and buffer delay			3		2		3	ns
t_{IO}	I/O input pad and buffer delay			3		2		3	ns
t_{SEXP}	Shared expander delay			7		8		9	ns
t_{PEXP}	Parallel expander delay			1		1		2	ns
t_{LAD}	Logic array delay			4		6		8	ns
t_{LAC}	Logic control array delay			4		6		8	ns
t_{OD}	Output buffer and pad delay	C1 = 35 pF		3		4		5	ns
t_{ZX}	Output buffer enable delay	C1 = 35 pF		6		6		9	ns
t_{XZ}	Output buffer disable delay	C1 = 5 pF		6		6		9	ns
t_{SU}	Register setup time		5		4		4		ns
t_H	Register hold time		4		4		5		ns
t_{RD}	Register delay			1		1		1	ns
t_{COMB}	Combinatorial delay			1		1		1	ns
t_{IC}	Array clock delay			4		6		8	ns
t_{EN}	Register enable time			4		6		8	ns
t_{GLOB}	Global control delay			0		1		3	ns
t_{PRE}	Register preset time			3		4		4	ns
t_{CLR}	Register clear time			3		4		4	ns
t_{PIA}	PIA delay			1		2		3	ns
t_{LPA}	Low-power adder	<i>Note (5)</i>		15		17		20	ns

Notes to tables:

- Operating conditions: $V_{CC} = 3.3 \text{ V} \pm 10\%$, $T_A = 0^\circ \text{ C}$ to 70° C for commercial use.
 $V_{CC} = 3.3 \text{ V} \pm 10\%$, $T_A = -40^\circ \text{ C}$ to 85° C for industrial use.
- This parameter is a guideline that is sample-tested only and is based on extensive device characterization. This parameter applies for both global and array clocking.
- Measured with a 16-bit loadable, enabled, up/down counter programmed into each LAB. I_{CC} is measured at 0° C .
- The f_{MAX} values represent the highest frequency for pipelined data.
- The t_{LPA} parameter must be added to the t_{LAD} , t_{LAC} , t_{IC} , t_{ACL} , t_{EN} , and t_{SEXP} parameters for macrocells running in low-power mode.

MAX 7000 3.3-V Device Power-Down/Chip-Enable Timing Parameters

Power-Down Timing Parameters		EPM7032V-12		EPM7032V-15		EPM7032V-20		
Symbol	Parameter	Min	Max	Min	Max	Min	Max	Unit
t_{ISUPD}	Input or I/O input setup time before power down	30		30		35		ns
t_{IHPD}	Input or I/O input hold time after power down	0		0		0		ns
t_{GCSUPD}	Global clock setup time before power down	20		20		25		ns
t_{GCHPD}	Global clock hold time after power down	0		0		0		ns
t_{ACSUPD}	Array clock setup time before power down	30		30		35		ns
t_{ACHPD}	Array clock hold time after power down	0		0		0		ns
t_{HPD}	Minimum high pulse width of power-down pin	800		800		900		ns
t_{LPD}	Minimum low pulse width of power-down pin	800		800		900		ns
t_{PDOWN}	Power down delay		800		800		900	ns

Chip-Enable Timing Parameters		EPM7032V-12		EPM7032V-15		EPM7032V-20		
Symbol	Parameter	Min	Max	Min	Max	Min	Max	Unit
t_{ISTCE}	Input or I/O input stable after chip enable		60		60		70	ns
t_{GCSTCE}	Global clock stable after chip enable		60		60		70	ns
t_{ACSTCE}	Array clock stable after chip enable		60		60		70	ns
t_{CE}	Data stable after chip enable		700		700		800	ns

Power Consumption

Supply power (P) versus frequency (f_{MAX} in MHz) for MAX 7000 devices is calculated with the following equation:

$$P = P_{\text{INT}} + P_{\text{IO}}$$

$$P = I_{\text{CCACTIVE}} \times V_{\text{CC}} + P_{\text{IO}}$$

The P_{IO} value, which depends on the device output load characteristics and switching frequency, can be calculated using the guidelines given in [Application Note 74 \(Evaluating Power for Altera Devices\)](#) in this data book.

The I_{CCACTIVE} value depends on the switching frequency and the application logic. The I_{CCACTIVE} value is calculated with the following equation:

$$I_{\text{CCACTIVE}} =$$

$$A \times MC_{\text{TON}} + B \times (MC_{\text{DEV}} - MC_{\text{TON}}) + C \times MC_{\text{USED}} \times f_{\text{MAX}} \times \text{togLC}$$

The parameters in this equation are:

- MC_{TON} = Number of macrocells with the Turbo Bit on, as reported in the MAX+PLUS II Report File (.rpt)
 MC_{DEV} = Number of macrocells in the device
 MC_{USED} = Total number of macrocells in the design, as reported in the MAX+PLUS II Report File (.rpt)
 f_{MAX} = Highest clock frequency to the device
 to_{GLC} = Average ratio of logic cells toggling at each clock (typically 0.125)
A, B, C = Constants, shown in [Table 5](#)

Device	Constant A	Constant B	Constant C
EPM7032	1.87	0.52	0.144
EPM7032V	0.83	0.40	0.048
EPM7064	1.63	0.74	0.144
EPM7096	1.63	0.74	0.144
EPM7128E	1.17	0.54	0.096
EPM7160E	1.17	0.54	0.096
EPM7192E	1.17	0.54	0.096
EPM7256E	1.17	0.54	0.096
EPM7032S, <i>Note (1)</i>	0.93	0.40	0.040
EPM7064S, <i>Note (1)</i>	0.93	0.40	0.040
EPM7096S, <i>Note (1)</i>	0.93	0.40	0.040
EPM7128S, <i>Note (1)</i>	0.93	0.40	0.040
EPM7160S, <i>Note (1)</i>	0.93	0.40	0.040
EPM7192S, <i>Note (1)</i>	0.93	0.40	0.040
EPM7256S, <i>Note (1)</i>	0.93	0.40	0.040

Note:

(1) Values for MAX 7000S devices are preliminary.

This calculation provides an I_{CC} estimate based on typical conditions using a pattern of a 16-bit, loadable, enabled, up/down counter in each LAB with no output load. Actual I_{CC} should be verified during operation because this measurement is sensitive to the actual pattern in the device and the environmental operating conditions.

[Figure 15](#) shows typical supply current versus frequency for MAX 7000 devices.

Figure 15. I_{CC} vs. Frequency for MAX 7000 Devices (Part 1 of 2)

EPM7032

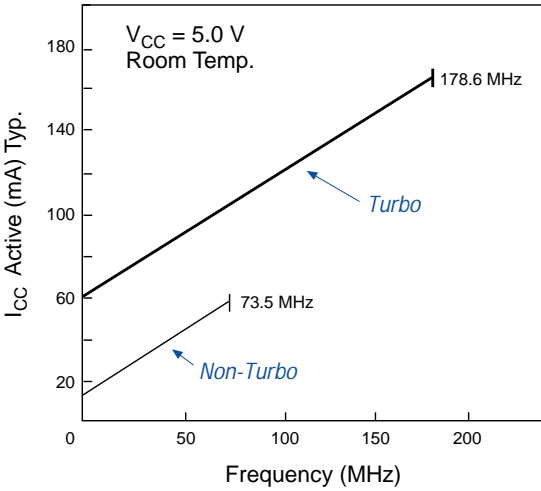

EPM7032V

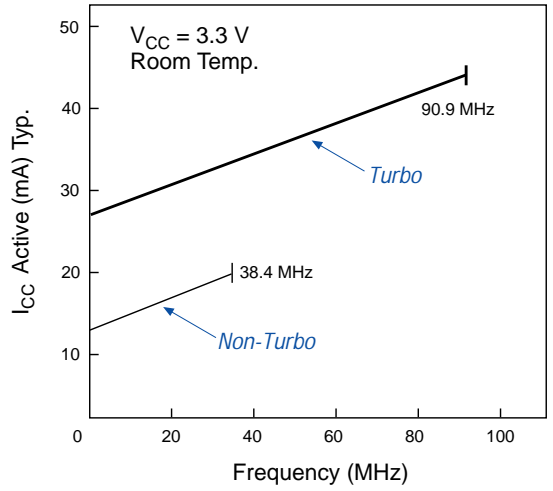

EPM7064

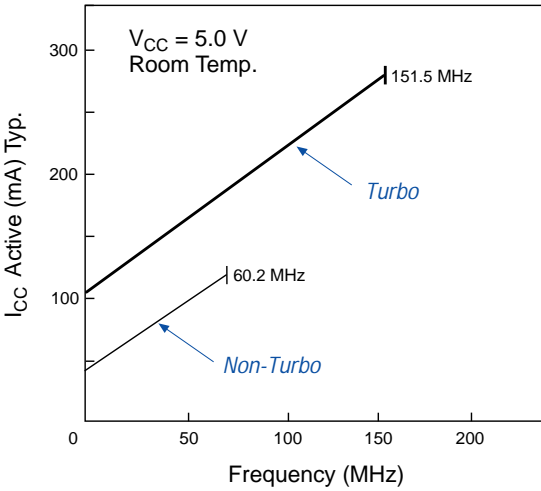

EPM7096

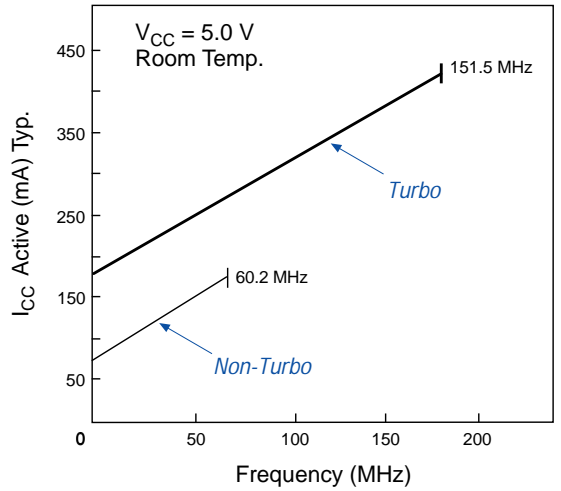
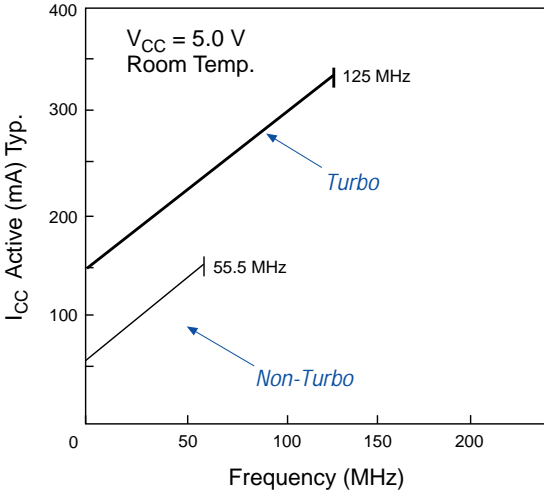
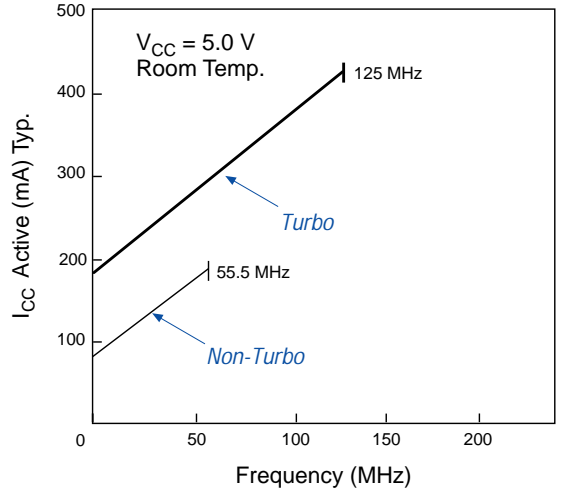

Figure 15. I_{CC} vs. Frequency for MAX 7000 Devices (Part 2 of 2)

EPM7128E



EPM7160E



EPM7192E

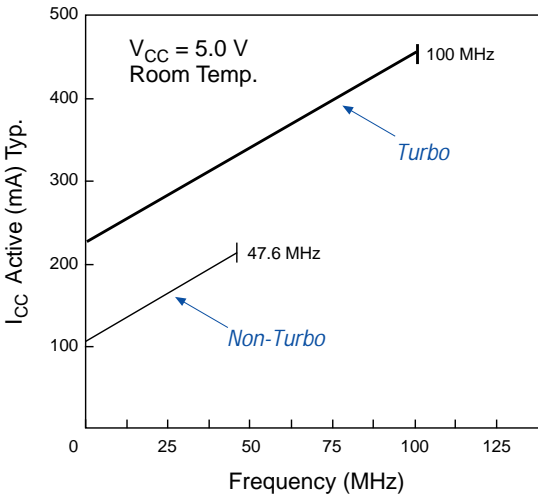

EPM7256E

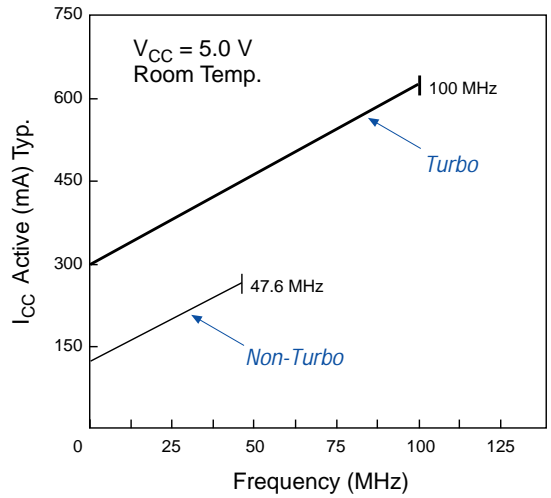
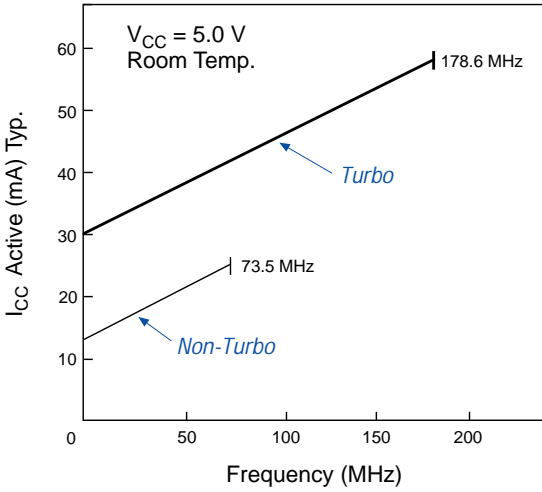

Figure 16 shows typical supply current versus frequency for MAX 7000S devices.

Figure 16. I_{CC} vs. Frequency for MAX 7000S Devices (Part 1 of 2)

Information on MAX 7000S devices is preliminary.

EPM7032S



EPM7064S

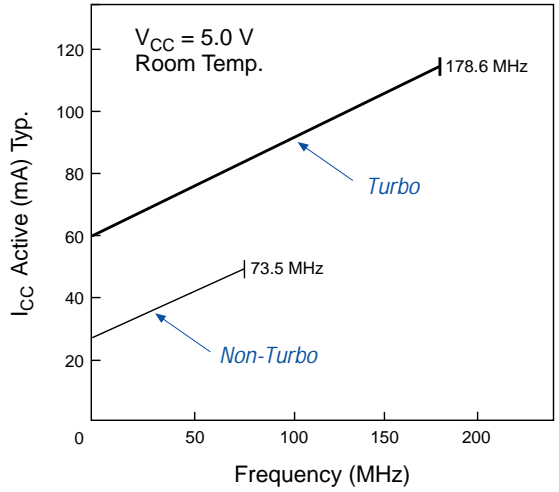

EPM7096S

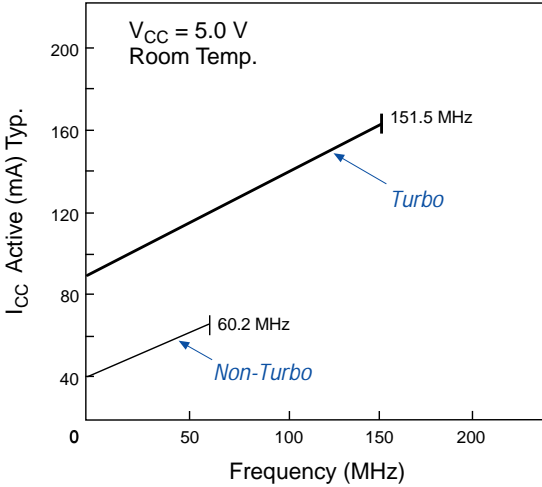

EPM7128S

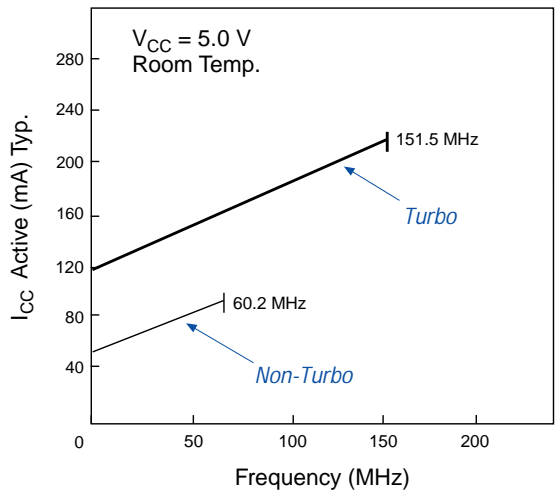
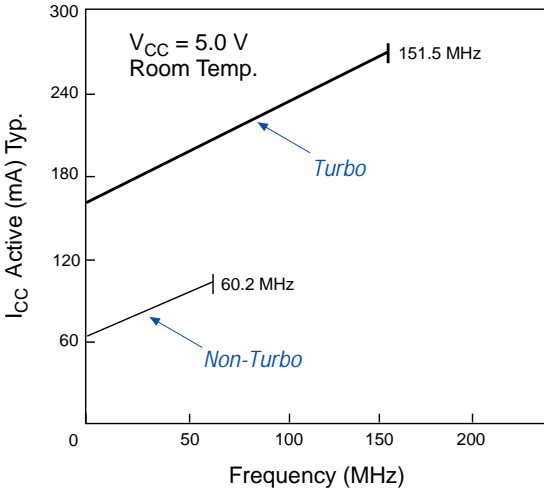

Figure 16. I_{CC} vs. Frequency for MAX 7000S Devices (Part 2 of 2)

Information on MAX 7000S devices is preliminary.

EPM7160S



EPM7192S

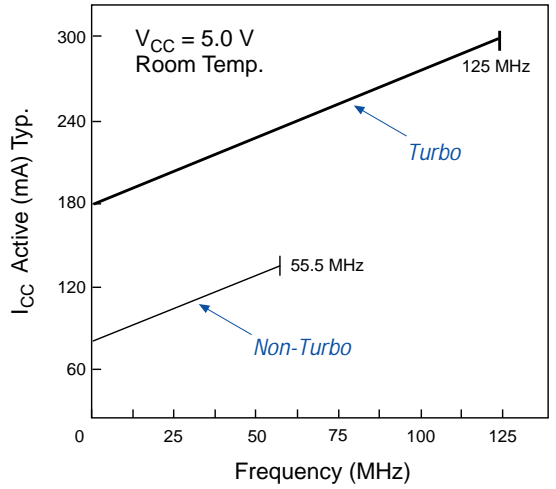

EPM7256S

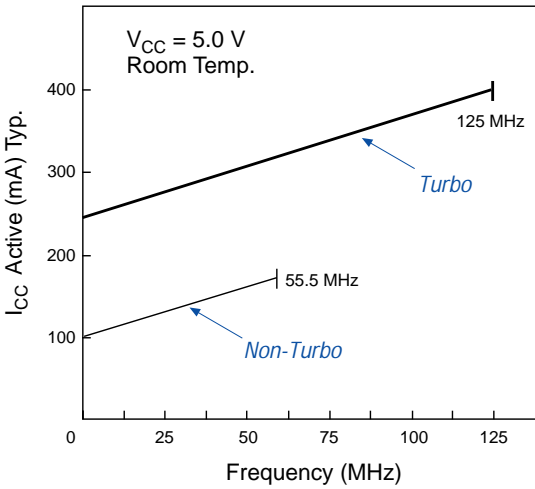

Device Pin-Outs

Tables 6 through 19 show the pin names and numbers for the pins in each MAX 7000 device package.

Pin Name	44-Pin J-Lead	44-Pin PQFP/TQFP
INPUT/GCLK	43	37
INPUT/GCLR _n	1	39
INPUT/OE1	44	38
INPUT/OE2/GCLK2 (2)	2	40
TDI (3)	7	1
TMS (3)	13	7
TCK (3)	32	26
TDO (3)	38	32
PD _n (4)	3	41
GND	10, 22, 30, 42	4, 16, 24, 36
VCC	3, 15, 23, 35	9, 17, 29, 41
No Connect (N.C.)	–	–
Total User I/O Pins	32	32

MC	LAB	44-Pin J-Lead	44-Pin PQFP/TQFP	MC	LAB	44-Pin J-Lead	44-Pin PQFP/TQFP
1	A	4	42	17	B	41	35
2	A	5	43	18	B	40	34
3	A	6	44	19	B	39	33
4	A	7 (3)	1 (3)	20	B	38 (3)	32 (3)
5	A	8	2	21	B	37	31
6	A	9	3	22	B	36	30
7	A	11	5	23	B	34	28
8	A	12	6	24	B	33	27
9	A	13 (3)	7 (3)	25	B	32 (3)	26 (3)
10	A	14	8	26	B	31	25
11	A	16	10	27	B	29	23
12	A	17	11	28	B	28	22
13	A	18	12	29	B	27	21
14	A	19	13	30	B	26	20
15	A	20	14	31	B	25	19
16	A	21	15	32	B	24	18

Notes to tables:

- (1) Information on MAX 7000S devices is preliminary.
- (2) The GCLK2 pin is available in MAX 7000S devices only.
- (3) In MAX 7000S devices, this pin may function as either a JTAG port or a user I/O pin. If the device is configured to use the JTAG ports for ISP, this pin is not available as a user I/O pin.
- (4) The PDn pin is available in the EPM7032V device only.

Table 8. EPM7064 & EPM7064S Dedicated Pin-Outs *Note (1)*

Dedicated Pin	44-Pin J-Lead	44-Pin TQFP	68-Pin J-Lead	84-Pin J-Lead	100-Pin PQFP
INPUT/GCLK	43	37	67	83	89
INPUT/GCLRn	1	39	1	1	91
INPUT/OE1	44	38	68	84	90
INPUT/OE2/GCLK2 (2)	2	40	2	2	92
TDI (3)	7	1	12	14	6
TMS (3)	13	7	19	23	17
TCK (3)	32	26	50	62	64
TDO (3)	38	32	57	71	75
GND	10, 22, 30, 42	4, 16, 24, 36	6, 16, 26, 34, 38, 48, 58, 66	7, 19, 32, 42, 47, 59, 72, 82	13, 28, 40, 45, 61, 76, 88, 97
VCCINT (5.0 V only)	3, 15, 23, 35	9, 17, 29, 41	3, 35	3, 43	41, 93
VCCIO (3.3 V or 5.0 V)	—	—	11, 21, 31, 43, 53, 63	13, 26, 38, 53, 66, 78	5, 20, 36, 53, 68, 84
No Connect (N.C.)	—	—	—	—	1, 2, 7, 9, 24, 26, 29, 30, 51, 52, 55, 57, 72, 74, 79, 80
Total User I/O Pins	32	32	48	64	64

Table 9. EPM7064 & EPM7064S I/O Pin-Outs *Note (1)*

MC	LAB	44-Pin J-Lead	44-Pin TQFP	68-Pin J-Lead	84-Pin J-Lead	100-Pin PQFP	MC	LAB	44-Pin J-Lead	44-Pin TQFP	68-Pin J-Lead	84-Pin J-Lead	100-Pin PQFP
1	A	12	6	18	22	16	17	B	21	15	33	41	39
2	A	–	–	–	21	15	18	B	–	–	–	40	38
3	A	11	5	17	20	14	19	B	20	14	32	39	37
4	A	9	3	15	18	12	20	B	19	13	30	37	35
5	A	8	2	14	17	11	21	B	18	12	29	36	34
6	A	–	–	13	16	10	22	B	–	–	28	35	33
7	A	–	–	–	15	8	23	B	–	–	–	34	32
8	A	7 (3)	1 (3)	12 (3)	14 (3)	6 (3)	24	B	17	11	27	33	31
9	A	–	–	10	12	4	25	B	16	10	25	31	27
10	A	–	–	–	11	3	26	B	–	–	–	30	25
11	A	6	44	9	10	100	27	B	–	–	24	29	23
12	A	–	–	8	9	99	28	B	–	–	23	28	22
13	A	–	–	7	8	98	29	B	–	–	22	27	21
14	A	5	43	5	6	96	30	B	14	8	20	25	19
15	A	–	–	–	5	95	31	B	–	–	–	24	18
16	A	4	42	4	4	94	32	B	13 (3)	7 (3)	19 (3)	23 (3)	17 (3)
33	C	24	18	36	44	42	49	D	33	27	51	63	65
34	C	–	–	–	45	43	50	D	–	–	–	64	66
35	C	25	19	37	46	44	51	D	34	28	52	65	67
36	C	26	20	39	48	46	52	D	36	30	54	67	69
37	C	27	21	40	49	47	53	D	37	31	55	68	70
38	C	–	–	41	50	48	54	D	–	–	56	69	71
39	C	–	–	–	51	49	55	D	–	–	–	70	73
40	C	28	22	42	52	50	56	D	38 (3)	32 (3)	57 (3)	71 (3)	75 (3)
41	C	29	23	44	54	54	57	D	39	33	59	73	77
42	C	–	–	–	55	56	58	D	–	–	–	74	78
43	C	–	–	45	56	58	59	D	–	–	60	75	81
44	C	–	–	46	57	59	60	D	–	–	61	76	82
45	C	–	–	47	58	60	61	D	–	–	62	77	83
46	C	31	25	49	60	62	62	D	40	34	64	79	85
47	C	–	–	–	61	63	63	D	–	–	–	80	86
48	C	32 (3)	26 (3)	50 (3)	62 (3)	64 (3)	64	D	41	35	65	81	87

Notes to tables:

- (1) Information on MAX 7000S devices is preliminary.
- (2) The GCLK2 pin is available in MAX 7000S devices only.
- (3) In MAX 7000S devices, this pin may function as either a JTAG port or a user I/O pin. If the device is configured to use the JTAG ports for ISP, this pin is not available as a user I/O pin.

Dedicated Pin	68-Pin J-Lead	84-Pin J-Lead	100-Pin PQFP
INPUT/GCLK1	67	83	89
INPUT/GCLRn	1	1	91
INPUT/OE1	68	84	90
INPUT/OE2/GCLK2 (2)	2	2	92
TDI (3)	12	14	6
TMS (3)	19	23	17
TCK (3)	50	62	64
TDO (3)	57	71	75
GND	6, 16, 26, 34, 38, 48, 58, 66	7, 19, 32, 42, 47, 59, 72, 82	13, 28, 40, 45, 61, 76, 88, 97
VCCINT (5.0 V only)	3, 35	3, 43	41, 93
VCCIO (3.3 V or 5.0 V)	11, 21, 31, 43, 53, 63	13, 26, 38, 53, 66, 78	5, 20, 36, 53, 68, 84
No Connect (N.C.)	–	6, 39, 46, 79	9, 24, 37, 44, 57, 72, 85, 96
Total User I/O Pins	48	60	72

MC	LAB	68-Pin J-Lead	84-Pin J-Lead	100-Pin PQFP	MC	LAB	68-Pin J-Lead	84-Pin J-Lead	100-Pin PQFP
1	A	13	16	8	17	B	23	28	23
2	A	–	–	–	18	B	–	–	–
3	A	–	15	7	19	B	22	27	22
4	A	12 (3)	14 (3)	6 (3)	20	B	–	–	21
5	A	–	–	4	21	B	20	25	19
6	A	10	12	3	22	B	–	24	18
7	A	–	–	–	23	B	–	–	–
8	A	9	11	2	24	B	19 (3)	23 (3)	17 (3)
9	A	8	10	1	25	B	18	22	16
10	A	–	–	–	26	B	–	–	–
11	A	–	9	100	27	B	17	21	15
12	A	7	8	99	28	B	–	20	14
13	A	–	–	98	29	B	15	18	12
14	A	5	5	95	30	B	–	–	11
15	A	–	–	–	31	B	–	–	–
16	A	4	4	94	32	B	14	17	10

Table 11. EPM7096 & EPM7096S I/O Pin-Outs (Part 2 of 2) *Note (1)*

MC	LAB	68-Pin J-Lead	84-Pin J-Lead	100-Pin PQFP	MC	LAB	68-Pin J-Lead	84-Pin J-Lead	100-Pin PQFP
33	C	33	41	39	49	D	36	44	42
34	C	–	–	–	50	D	–	–	–
35	C	32	40	38	51	D	37	45	43
36	C	–	–	35	52	D	–	–	46
37	C	30	37	34	53	D	39	48	47
38	C	–	36	33	54	D	–	49	48
39	C	–	–	–	55	D	–	–	–
40	C	29	35	32	56	D	40	50	49
41	C	28	34	31	57	D	41	51	50
42	C	–	–	–	58	D	–	–	–
43	C	27	33	30	59	D	42	52	51
44	C	–	–	29	60	D	–	–	52
45	C	25	31	27	61	D	44	54	54
46	C	–	30	26	62	D	–	55	55
47	C	–	–	–	63	D	–	–	–
48	C	24	29	25	64	D	45	56	56
65	E	46	57	58	81	F	56	69	73
66	E	–	–	–	82	F	–	–	–
67	E	47	58	59	83	F	–	70	74
68	E	–	–	60	84	F	57 (3)	71 (3)	75 (3)
69	E	49	60	62	85	F	–	–	77
70	E	–	61	63	86	F	59	73	78
71	E	–	–	–	87	F	–	–	–
72	E	50 (3)	62 (3)	64 (3)	88	F	60	74	79
73	E	51	63	65	89	F	61	75	80
74	E	–	–	–	90	F	–	–	–
75	E	52	64	66	91	F	–	76	81
76	E	–	65	67	92	F	62	77	82
77	E	54	67	69	93	F	–	–	83
78	E	–	–	70	94	F	64	80	86
79	E	–	–	–	95	F	–	–	–
80	E	55	68	71	96	F	65	81	87

Notes to tables:

- (1) Information on MAX 7000S devices is preliminary.
- (2) The GCLK2 pin is available in MAX 7000S devices only.
- (3) In MAX 7000S devices, this pin may function as either a JTAG port or a user I/O pin. If the device is configured to use the JTAG ports for ISP, this pin is not available as a user I/O pin.

Table 12. EPM7128E & EPM7128S Dedicated Pin-Outs *Note (1)*

Updates

Dedicated Pin	84-Pin J-Lead	100-Pin PQFP	100-Pin TQFP	160-Pin PQFP
INPUT/GCLK1	83	89	–	139
INPUT/GCLR _n	1	91	–	141
INPUT/OE1	84	90	88	140
INPUT/OE2/GCLK2	2	92	87	142
TDI (2)	14	6	4	9
TMS (2)	23	17	15	22
TCK (2)	62	64	62	99
TDO (2)	71	75	73	112
GND	7, 19, 32, 42, 47, 59, 72, 82	13, 28, 40, 45, 61, 76, 88, 97	11, 26, 38, 43, 59, 74, 86	17, 42, 60, 66, 95, 113, 138, 148
VCCINT (5.0 V only)	3, 43	41, 93	39, 91	61, 143
VCCIO (3.3 V or 5.0 V)	13, 26, 38, 53, 66, 78	5, 20, 36, 53, 68, 84	3, 18, 34, 51, 66	8, 26, 55, 79, 104, 133
No Connect (N.C.)	–	–	–	1, 2, 3, 4, 5, 6, 7, 34, 35, 36, 37, 38, 39, 40, 44, 45, 46, 47, 74, 75, 76, 77, 81, 82, 83, 84, 85, 86, 87, 114, 115, 116, 117, 118, 119, 120, 124, 125, 126, 127, 154, 155, 156, 157
Total User I/O Pins	64	80	80	96

Table 13. EPM7128E & EPM7128S I/O Pin-Outs (Part 1 of 2) *Note (1)*

Updates

MC	LAB	84-Pin J-Lead	100-Pin PQFP	100-Pin TQFP	160-Pin PQFP	MC	LAB	84-Pin J-Lead	100-Pin PQFP	100-Pin TQFP	160-Pin PQFP
1	A	–	4	2	160	17	B	22	16	14	21
2	A	–	–	–	–	18	B	–	–	–	–
3	A	12	3	1	159	19	B	21	15	13	20
4	A	–	–	–	158	20	B	–	–	–	19
5	A	11	2	100	153	21	B	20	14	12	18
6	A	10	1	99	152	22	B	–	12	10	16
7	A	–	–	–	–	23	B	–	–	–	–
8	A	9	100	98	151	24	B	18	11	9	15
9	A	–	99	97	150	25	B	17	10	8	14
10	A	–	–	–	–	26	B	–	–	–	–
11	A	8	98	96	149	27	B	16	9	7	13
12	A	–	–	–	147	28	B	–	–	–	12
13	A	6	96	94	146	29	B	15	8	6	11
14	A	5	95	93	145	30	B	–	7	5	10
15	A	–	–	–	–	31	B	–	–	–	–
16	A	4	94	92	144	32	B	14 (2)	6 (2)	4 (2)	9 (2)
33	C	–	27	25	41	49	D	41	39	37	59
34	C	–	–	–	–	50	D	–	–	–	–
35	C	31	26	24	33	51	D	40	38	36	58
36	C	–	–	–	32	52	D	–	–	–	57
37	C	30	25	23	31	53	D	39	37	35	56
38	C	29	24	22	30	54	D	–	35	33	54
39	C	–	–	–	–	55	D	–	–	–	–
40	C	28	23	21	29	56	D	37	34	32	53
41	C	–	22	20	28	57	D	36	33	31	52
42	C	–	–	–	–	58	D	–	–	–	–
43	C	27	21	19	27	59	D	35	32	30	51
44	C	–	–	–	25	60	D	–	–	–	50
45	C	25	19	17	24	61	D	34	31	29	49
46	C	24	18	16	23	62	D	–	30	28	48
47	C	–	–	–	–	63	D	–	–	–	–
48	C	23 (2)	17 (2)	15 (2)	22 (2)	64	D	33	29	27	43

Table 13. EPM7128E & EPM7128S I/O Pin-Outs (Part 2 of 2)

Note (1)

Updates

MC	LAB	84-Pin J-Lead	100-Pin PQFP	100-Pin TQFP	160-Pin PQFP	MC	LAB	84-Pin J-Lead	100-Pin PQFP	100-Pin TQFP	160-Pin PQFP
65	E	44	42	40	62	81	F	–	54	52	80
66	E	–	–	–	–	82	F	–	–	–	–
67	E	45	43	41	63	83	F	54	55	53	88
68	E	–	–	–	64	84	F	–	–	–	89
69	E	46	44	42	65	85	F	55	56	54	90
70	E	–	46	44	67	86	F	56	57	55	91
71	E	–	–	–	–	87	F	–	–	–	–
72	E	48	47	45	68	88	F	57	58	56	92
73	E	49	48	45	69	89	F	–	59	57	93
74	E	–	–	–	–	90	F	–	–	–	–
75	E	50	49	47	70	91	F	58	60	58	94
76	E	–	–	–	71	92	F	–	–	–	96
77	E	51	50	48	72	93	F	60	62	60	97
78	E	–	51	49	73	94	F	61	63	61	98
79	E	–	–	–	–	95	F	–	–	–	–
80	E	52	52	50	78	96	F	62 (2)	64 (2)	62 (2)	99 (2)
97	G	63	65	63	100	113	H	–	77	75	121
98	G	–	–	–	–	114	H	–	–	–	–
99	G	64	66	64	101	115	H	73	78	76	122
100	G	–	–	–	102	116	H	–	–	–	123
101	G	65	67	65	103	117	H	74	79	77	128
102	G	–	69	67	105	118	H	75	80	78	129
103	G	–	–	–	–	119	H	–	–	–	–
104	G	67	70	68	106	120	H	76	81	79	130
105	G	68	71	69	107	121	H	–	82	80	131
106	G	–	–	–	–	122	H	–	–	–	–
107	G	69	72	70	108	123	H	77	83	81	132
108	G	–	–	–	109	124	H	–	–	–	134
109	G	70	73	71	110	125	H	79	85	83	135
110	G	–	74	72	111	126	H	80	86	84	136
111	G	–	–	–	–	127	H	–	–	–	–
112	G	71 (2)	75 (2)	73 (2)	112 (2)	128	H	81	87	85	137

Notes to tables:

- (1) Information on MAX 7000S devices is preliminary.
- (2) In MAX 7000S devices, this pin may function as either a JTAG port or a user I/O pin. If the device is configured to use the JTAG ports for boundary-scan testing or for ISP, this pin is not available as a user I/O pin.

Table 14. EPM7160E & EPM7160S Dedicated Pin-Outs <i>Note (1)</i>			
Dedicated Pin	84-Pin J-Lead	100-Pin PQFP	160-Pin PQFP
INPUT/GCLK1	83	89	139
INPUT/GCLRn	1	91	141
INPUT/OE1	84	90	140
INPUT/OE2/GCLK2	2	92	142
TDI (2)	14	6	9
TMS (2)	23	17	22
TCK (2)	62	64	99
TDO (2)	71	75	112
GND	7, 19, 32, 42, 47, 59, 72, 82	13, 28, 40, 45, 61, 76, 88, 97	17, 42, 60, 66, 95, 113, 138, 148
VCCINT (5.0 V only)	3, 43	41, 93	61, 143
VCCIO (3.3 V or 5.0 V)	13, 26, 38, 53, 66, 78	5, 20, 36, 53, 68, 84	8, 26, 55, 79, 104, 133
No Connect (N.C.)	6, 39, 46, 79	–	1, 2, 3, 4, 5, 6, 34, 35, 36, 37, 38, 39, 40, 45, 46, 47, 74, 75, 76, 81, 82, 83, 84, 85, 86, 87, 115, 116, 117, 118, 119, 120, 124, 125, 126, 127, 154, 155, 156, 157
Total User I/O Pins	60	80	100

Table 15. EPM7160E & EPM7160S I/O Pin-Outs (Part 1 of 3) *Note (1)*

MC	LAB	84-Pin J-Lead	100-Pin PQFP	160-Pin PQFP	MC	LAB	84-Pin J-Lead	100-Pin PQFP	160-Pin PQFP
1	A	11	2	158	17	B	18	11	15
2	A	–	–	–	18	B	–	–	–
3	A	10	1	153	19	B	17	10	14
4	A	–	–	–	20	B	–	–	–
5	A	–	–	152	21	B	–	–	13
6	A	–	100	151	22	B	–	9	12
7	A	–	–	–	23	B	–	–	–
8	A	9	99	150	24	B	16	8	11
9	A	8	98	149	25	B	15	7	10
10	A	–	–	–	26	B	–	–	–
11	A	5	96	147	27	B	14 (2)	6 (2)	9 (2)
12	A	–	–	–	28	B	–	–	–
13	A	–	–	146	29	B	–	–	7
14	A	–	95	145	30	B	–	4	160
15	A	–	–	–	31	B	–	–	–
16	A	4	94	144	32	B	12	3	159
33	C	–	21	27	49	D	–	–	48
34	C	–	–	–	50	D	–	–	–
35	C	25	19	25	51	D	33	30	44
36	C	–	–	–	52	D	–	–	–
37	C	–	–	24	53	D	–	29	43
38	C	24	18	23	54	D	31	27	41
39	C	–	–	–	55	D	–	–	–
40	C	23 (2)	17 (2)	22 (2)	56	D	30	26	33
41	C	–	12	16	57	D	–	–	32
42	C	–	–	–	58	D	–	–	–
43	C	20	14	18	59	D	29	25	31
44	C	–	–	–	60	D	–	–	–
45	C	–	–	19	61	D	–	24	30
46	C	21	15	20	62	D	28	23	29
47	C	–	–	–	63	D	–	–	–
48	C	22	16	21	64	D	27	22	28

Table 15. EPM7160E & EPM7160S I/O Pin-Outs (Part 2 of 3) *Note (1)*

MC	LAB	84-Pin J-Lead	100-Pin PQFP	160-Pin PQFP	MC	LAB	84-Pin J-Lead	100-Pin PQFP	160-Pin PQFP
65	E	–	–	59	81	F	–	–	62
66	E	–	–	–	82	F	–	–	–
67	E	41	39	58	83	F	44	42	63
68	E	–	–	–	84	F	–	–	–
69	E	–	38	57	85	F	–	43	64
70	E	40	37	56	86	F	45	44	65
71	E	–	–	–	87	F	–	–	–
72	E	37	35	54	88	F	48	46	67
73	E	–	–	53	89	F	–	–	68
74	E	–	–	–	90	F	–	–	–
75	E	36	34	52	91	F	49	47	69
76	E	–	–	–	92	F	–	–	–
77	E	–	33	51	93	F	–	48	70
78	E	35	32	50	94	F	50	49	71
79	E	–	–	–	95	F	–	–	–
80	E	34	31	49	96	F	51	50	72
97	G	–	–	73	113	H	–	60	94
98	G	–	–	–	114	H	–	–	–
99	G	52	51	77	115	H	60	62	96
100	G	–	–	–	116	H	–	–	–
101	G	–	52	78	117	H	–	–	97
102	G	54	54	80	118	H	61	63	98
103	G	–	–	–	119	H	–	–	–
104	G	55	55	88	120	H	62 (2)	64 (2)	99 (2)
105	G	–	–	89	121	H	–	69	105
106	G	–	–	–	122	H	–	–	–
107	G	56	56	90	123	H	65	67	103
108	G	–	–	–	124	H	–	–	–
109	G	–	57	91	125	H	–	–	102
110	G	57	58	92	126	H	64	66	101
111	G	–	–	–	127	H	–	–	–
112	G	58	59	93	128	H	63	65	100

Table 15. EPM7160E & EPM7160S I/O Pin-Outs (Part 3 of 3) *Note (1)*

MC	LAB	84-Pin J-Lead	100-Pin PQFP	160-Pin PQFP	MC	LAB	84-Pin J-Lead	100-Pin PQFP	160-Pin PQFP
129	I	67	70	106	145	J	74	79	123
130	I	–	–	–	146	J	–	–	–
131	I	68	71	107	147	J	75	80	128
132	I	–	–	–	148	J	–	–	–
133	I	–	–	108	149	J	–	–	129
134	I	–	72	109	150	J	–	81	130
135	I	–	–	–	151	J	–	–	–
136	I	69	73	110	152	J	76	82	131
137	I	70	74	111	153	J	77	83	132
138	I	–	–	–	154	J	–	–	–
139	I	71 (2)	75 (2)	112 (2)	155	J	80	85	134
140	I	–	–	–	156	J	–	–	–
141	I	–	–	114	157	J	–	–	135
142	I	–	77	121	158	J	–	86	136
143	I	–	–	–	159	J	–	–	–
144	I	73	78	122	160	J	81	87	137

Notes to tables:

- (1) Information on MAX 7000S devices is preliminary.
- (2) For MAX 7000S devices, this pin may function as either a JTAG port or a user I/O pin. If the device is configured to use the JTAG ports for boundary-scan testing or with ISP, this pin is not available as a user I/O pin.

Dedicated Pin	160-Pin PGA	160-Pin PQFP
INPUT/GCLK1	M8	139
INPUT/GCLRn	N8	141
INPUT/OE1	P8	140
INPUT/OE2/GCLK2	R8	142
TDI (2)	P9	146
TMS (2)	G15	23
TCK (2)	G2	98
TDO (2)	R7	135
GND	C4, C6, C11, D7, D9, D13, G4, H12, J4, M7, M9, M13, N4, N11	3, 18, 32, 47, 57, 64, 66, 81, 96, 111, 126, 138, 143, 148
VCCINT (5.0 V only)	C7, C9, N7, N9	56, 65, 137, 144
VCCIO (3.3 V or 5.0 V)	C5, C10, C12, D3, G12, H4, J12, M3, N5, N12	10, 25, 40, 55, 74, 89, 103, 118, 133, 155
No Connect (N.C.)	A1, A2, A14, A15, R1, R2, R14, R15	1, 11, 39, 54, 67, 82, 110, 120
Total User I/O Pins	120	120

Table 17. EPM7192E & EPM7192S I/O Pin-Outs (Part 1 of 2) *Note (1)*

MC	LAB	160-Pin PGA	160-Pin PQFP	MC	LAB	160-Pin PGA	160-Pin PQFP	MC	LAB	160-Pin PGA	160-Pin PQFP
1	A	M12	156	17	B	L14	8	33	C	H14	21
2	A	–	–	18	B	–	–	34	C	–	–
3	A	P11	154	19	B	M14	7	35	C	J13	20
4	A	–	–	20	B	–	–	36	C	–	–
5	A	P12	153	21	B	M15	6	37	C	H15	19
6	A	P10	152	22	B	N14	5	38	C	J15	17
7	A	–	–	23	B	–	–	39	C	–	–
8	A	R12	151	24	B	N15	4	40	C	J14	16
9	A	N10	150	25	B	P15	2	41	C	K15	15
10	A	–	–	26	B	–	–	42	C	–	–
11	A	R11	149	27	B	N13	160	43	C	K13	14
12	A	–	–	28	B	–	–	44	C	–	–
13	A	R10	147	29	B	P14	159	45	C	L15	13
14	A	P9 (2)	146 (2)	30	B	P13	158	46	C	K14	12
15	A	–	–	31	B	–	–	47	C	–	–
16	A	R9	145	32	B	R13	157	48	C	L13	9
49	D	D15	33	65	E	B12	45	81	F	D8	60
50	D	–	–	66	E	–	–	82	F	–	–
51	D	E15	31	67	E	B13	44	83	F	A9	59
52	D	–	–	68	E	–	–	84	F	–	–
53	D	E14	30	69	E	C13	43	85	F	C8	58
54	D	F15	29	70	E	B14	42	86	F	B9	53
55	D	–	–	71	E	–	–	87	F	–	–
56	D	F13	28	72	E	C14	41	88	F	A10	52
57	D	G14	27	73	E	D12	38	89	F	B10	51
58	D	–	–	74	E	–	–	90	F	–	–
59	D	F14	26	75	E	B15	37	91	F	A11	50
60	D	–	–	76	E	–	–	92	F	–	–
61	D	G13	24	77	E	D14	36	93	F	B11	49
62	D	G15 (2)	23 (2)	78	E	C15	35	94	F	A12	48
63	D	–	–	79	E	–	–	95	F	–	–
64	D	H13	22	80	E	E13	34	96	F	A13	46

Table 17. EPM7192E & EPM7192S I/O Pin-Outs (Part 2 of 2) *Note (1)*

MC	LAB	160-Pin PGA	160-Pin PQFP	MC	LAB	160-Pin PGA	160-Pin PQFP	MC	LAB	160-Pin PGA	160-Pin PQFP
97	G	A8	61	113	H	A3	76	129	I	E3	88
98	G	–	–	114	H	–	–	130	I	–	–
99	G	B8	62	115	H	B4	77	131	I	F3	90
100	G	–	–	116	H	–	–	132	I	–	–
101	G	A7	63	117	H	B3	78	133	I	E2	91
102	G	A6	68	118	H	C3	79	134	I	F2	92
103	G	–	–	119	H	–	–	135	I	–	–
104	G	B7	69	120	H	B2	80	136	I	E1	93
105	G	A5	70	121	H	B1	83	137	I	G3	94
106	G	–	–	122	H	–	–	138	I	–	–
107	G	B6	71	123	H	C2	84	139	I	F1	95
108	G	–	–	124	H	–	–	140	I	–	–
109	G	A4	72	125	H	C1	85	141	I	G1	97
110	G	B5	73	126	H	D2	86	142	I	G2 (2)	98 (2)
111	G	–	–	127	H	–	–	143	I	–	–
112	G	D4	75	128	H	D1	87	144	I	H1	99
145	J	H2	100	161	K	L2	113	177	L	R3	125
146	J	–	–	162	K	–	–	178	L	–	–
147	J	J1	101	163	K	N1	114	179	L	R4	127
148	J	–	–	164	K	–	–	180	L	–	–
149	J	H3	102	165	K	L3	115	181	L	M4	128
150	J	J3	104	166	K	P1	116	182	L	R5	129
151	J	–	–	167	K	–	–	183	L	–	–
152	J	K1	105	168	K	M2	117	184	L	P5	130
153	J	J2	106	169	K	N2	119	185	L	R6	131
154	J	–	–	170	K	–	–	186	L	–	–
155	J	K2	107	171	K	P2	121	187	L	P6	132
156	J	–	–	172	K	–	–	188	L	–	–
157	J	K3	108	173	K	N3	122	189	L	N6	134
158	J	L1	109	174	K	P3	123	190	L	R7 (2)	135 (2)
159	J	–	–	175	K	–	–	191	L	–	–
160	J	M1	112	176	K	P4	124	192	L	P7	136

Notes to tables:

- (1) Information on MAX 7000S devices is preliminary.
- (2) For MAX 7000S devices, this pin may function as either a JTAG port or a user I/O pin. If the device is configured to use the JTAG ports for ISP, this pin is not available as a user I/O pin.

Table 18. EPM7256E & EPM7256S Dedicated Pin-Outs *Note (1)*

Dedicated Pin	160-Pin PQFP (2)	192-Pin PGA	208-Pin RQFP
INPUT/GCLK1	139	P9	184
INPUT/GCLR _n	141	R9	182
INPUT/OE1	140	T9	183
INPUT/OE2/GCLK2	142	U9	181
TDI (3)	146	U10	176
TMS (3)	23	H15	127
TCK (3)	98	H3	30
TDO (3)	135	U8	189
GND	3, 18, 32, 47, 57, 64, 66, 81, 96, 111, 126, 138, 143, 148	C7, C13, D4, D8, D10, G14, H4, K14, L4, P8, P10, P15, R4, R11	14, 32, 50, 72, 75, 82, 94, 116, 134, 152, 174, 180, 185, 200
VCCINT (5.0 V only)	56, 65, 137, 144	D7, D11, P7, P11	74, 83, 179, 186
VCCIO (3.3 V or 5.0 V)	10, 25, 40, 55, 74, 89, 103, 118, 133, 155	C5, C11, D14, G4, H14, K4, L14, P3, R5, R14	5, 23, 41, 63, 85, 107, 125, 143, 165, 191
No Connect (N.C.)	–	–	1, 2, 51, 52, 53, 54, 103, 104, 105, 106, 155, 156, 157, 158, 207, 208.
Total User I/O Pins	128	160	160

Table 19. EPM7256E & EPM7256S I/O Pin-Outs (Part 1 of 4) *Note (1)*

MC	LAB	160-Pin PQFP (2)	192-Pin PGA	208-Pin RQFP	MC	LAB	160-Pin PQFP (2)	192-Pin PGA	208-Pin RQFP
1	A	2	U17	153	17	B	12	N17	141
2	A	–	–	–	18	B	–	–	–
3	A	1	R16	154	19	B	11	M16	142
4	A	–	–	–	20	B	–	–	–
5	A	160	P14	159	21	B	9	M15	144
6	A	–	U16	160	22	B	–	P17	145
7	A	–	–	–	23	B	–	–	–
8	A	159	R15	161	24	B	8	N16	146
9	A	158	U15	162	25	B	7	R17	147
10	A	–	–	–	26	B	–	–	–
11	A	157	T15	163	27	B	6	P16	148
12	A	–	–	–	28	B	–	–	–
13	A	156	U14	164	29	B	5	T17	149
14	A	–	U13	166	30	B	–	N15	150
15	A	–	–	–	31	B	–	–	–
16	A	154	T14	167	32	B	4	T16	151
33	C	39	B17	108	49	D	49	A14	92
34	C	–	–	–	50	D	–	–	–
35	C	38	C15	109	51	D	48	B12	93
36	C	–	–	–	52	D	–	–	–
37	C	37	C17	110	53	D	46	B13	95
38	C	–	C16	111	54	D	–	A15	96
39	C	–	–	–	55	D	–	–	–
40	C	36	D17	112	56	D	45	B14	97
41	C	35	D15	113	57	D	44	A16	98
42	C	–	–	–	58	D	–	–	–
43	C	34	E17	114	59	D	43	C14	99
44	C	–	–	–	60	D	–	–	–
45	C	33	D16	115	61	D	42	B16	100
46	C	–	E15	117	62	D	–	B15	101
47	C	–	–	–	63	D	–	–	–
48	C	31	F16	118	64	D	41	A17	102

Table 19. EPM7256E & EPM7256S I/O Pin-Outs (Part 2 of 4) *Note (1)*

MC	LAB	160-Pin PQFP (2)	192-Pin PGA	208-Pin RQFP	MC	LAB	160-Pin PQFP (2)	192-Pin PGA	208-Pin RQFP
65	E	153	U12	168	81	F	21	J16	130
66	E	–	–	–	82	F	–	–	–
67	E	152	R13	169	83	F	20	J15	131
68	E	–	–	–	84	F	–	–	–
69	E	151	U11	170	85	F	19	K17	132
70	E	–	T13	171	86	F	–	J14	133
71	E	–	–	–	87	F	–	–	–
72	E	150	T11	172	88	F	17	K16	135
73	E	149	T12	173	89	F	16	K15	136
74	E	–	–	–	90	F	–	–	–
75	E	147	R12	175	91	F	15	L17	137
76	E	–	–	–	92	F	–	–	–
77	E	146 (3)	U10 (3)	176 (3)	93	F	14	L16	138
78	E	–	R10	177	94	F	–	M17	139
79	E	–	–	–	95	F	–	–	–
80	E	145	T10	178	96	F	13	L15	140
97	G	30	E16	119	113	H	60	C9	79
98	G	–	–	–	114	H	–	–	–
99	G	29	F17	120	115	H	59	D9	80
100	G	–	–	–	116	H	–	–	–
101	G	28	F15	121	117	H	58	C10	81
102	G	–	G16	122	118	H	–	A10	84
103	G	–	–	–	119	H	–	–	–
104	G	27	G15	123	120	H	54	A11	86
105	G	26	G17	124	121	H	53	B10	87
106	G	–	–	–	122	H	–	–	–
107	G	24	H17	126	123	H	52	A12	88
108	G	–	–	–	124	H	–	–	–
109	G	23 (3)	H15 (3)	127 (3)	125	H	51	B11	89
110	G	–	J17	128	126	H	–	A13	90
111	G	–	–	–	127	H	–	–	–
112	G	22	H16	129	128	H	50	C12	91

Table 19. EPM7256E & EPM7256S I/O Pin-Outs (Part 3 of 4) *Note (1)*

MC	LAB	160-Pin PQFP (2)	192-Pin PGA	208-Pin RQFP	MC	LAB	160-Pin PQFP (2)	192-Pin PGA	208-Pin RQFP
129	I	128	U6	197	145	J	100	J2	27
130	I	–	–	–	146	J	–	–	–
131	I	129	T5	196	147	J	101	J3	26
132	I	–	–	–	148	J	–	–	–
133	I	130	U7	195	149	J	102	K1	25
134	I	–	T6	194	150	J	–	J4	24
135	I	–	–	–	151	J	–	–	–
136	I	131	T7	193	152	J	104	K2	22
137	I	132	R6	192	153	J	105	K3	21
138	I	–	–	–	154	J	–	–	–
139	I	134	R7	190	155	J	106	L1	20
140	I	–	–	–	156	J	–	–	–
141	I	135 (3)	U8 (3)	189 (3)	157	J	107	L2	19
142	I	–	R8	188	158	J	–	M1	18
143	I	–	–	–	159	J	–	–	–
144	I	136	T8	187	160	J	108	L3	17
161	K	91	F3	38	177	L	61	B9	78
162	K	–	–	–	178	L	–	–	–
163	K	92	F1	37	179	L	62	C8	77
164	K	–	–	–	180	L	–	–	–
165	K	93	E2	36	181	L	63	A9	76
166	K	–	G2	35	182	L	–	A8	73
167	K	–	–	–	183	L	–	–	–
168	K	94	G3	34	184	L	67	A7	71
169	K	95	G1	33	185	L	68	B8	70
170	K	–	–	–	186	L	–	–	–
171	K	97	H1	31	187	L	69	A6	69
172	K	–	–	–	188	L	–	–	–
173	K	98 (3)	H3 (3)	30 (3)	189	L	70	B7	68
174	K	–	J1	29	190	L	–	A5	67
175	K	–	–	–	191	L	–	–	–
176	K	99	H2	28	192	L	71	C6	66

Table 19. EPM7256E & EPM7256S I/O Pin-Outs (Part 4 of 4) *Note (1)*

MC	LAB	160-Pin PQFP (2)	192-Pin PGA	208-Pin RQFP	MC	LAB	160-Pin PQFP (2)	192-Pin PGA	208-Pin RQFP
193	M	119	U1	4	209	N	109	N1	16
194	M	–	–	–	210	N	–	–	–
195	M	120	R2	3	211	N	110	M2	15
196	M	–	–	–	212	N	–	–	–
197	M	121	R3	206	213	N	112	M3	13
198	M	–	U2	205	214	N	–	P1	12
199	M	–	–	–	215	N	–	–	–
200	M	122	P4	204	216	N	113	N2	11
201	M	123	U3	203	217	N	114	R1	10
202	M	–	–	–	218	N	–	–	–
203	M	124	T3	202	219	N	115	P2	9
204	M	–	–	–	220	N	–	–	–
205	M	125	U4	201	221	N	116	T1	8
206	M	–	U5	199	222	N	–	N3	7
207	M	–	–	–	223	N	–	–	–
208	M	127	T4	198	224	N	117	T2	6
225	O	82	B1	49	241	P	72	A4	65
226	O	–	–	–	242	P	–	–	–
227	O	83	C3	48	243	P	73	B6	64
228	O	–	–	–	244	P	–	–	–
229	O	84	C1	47	245	P	75	B5	62
230	O	–	D3	46	246	P	–	A3	61
231	O	–	–	–	247	P	–	–	–
232	O	85	D1	45	248	P	76	B4	60
233	O	86	C2	44	249	P	77	A2	59
234	O	–	–	–	250	P	–	–	–
235	O	87	E1	43	251	P	78	C4	58
236	O	–	–	–	252	P	–	–	–
237	O	88	E3	42	253	P	79	B2	57
238	O	–	D2	40	254	P	–	B3	56
239	O	–	–	–	255	P	–	–	–
240	O	90	F2	39	256	P	80	A1	55

Notes to tables:

- (1) Information on MAX 7000S devices is preliminary.
- (2) Be sure to perform a complete thermal analysis before committing a design to this device package. See the *Operating Requirements for Altera Devices Data Sheet* in this data book for more information.
- (3) For MAX 7000S devices, this pin may function as either a JTAG port or a user I/O pin. If the device is configured to use the JTAG ports for ISP, this pin is not available as a user I/O pin.

Pin-Out Diagrams

Figures 17 through 23 show the package pin-out diagrams for MAX 7000 devices.

Figure 17. 44-Pin Package Pin-Out Diagram

Package outlines not drawn to scale. Pin functions shown in parentheses are for MAX 7000S devices only.

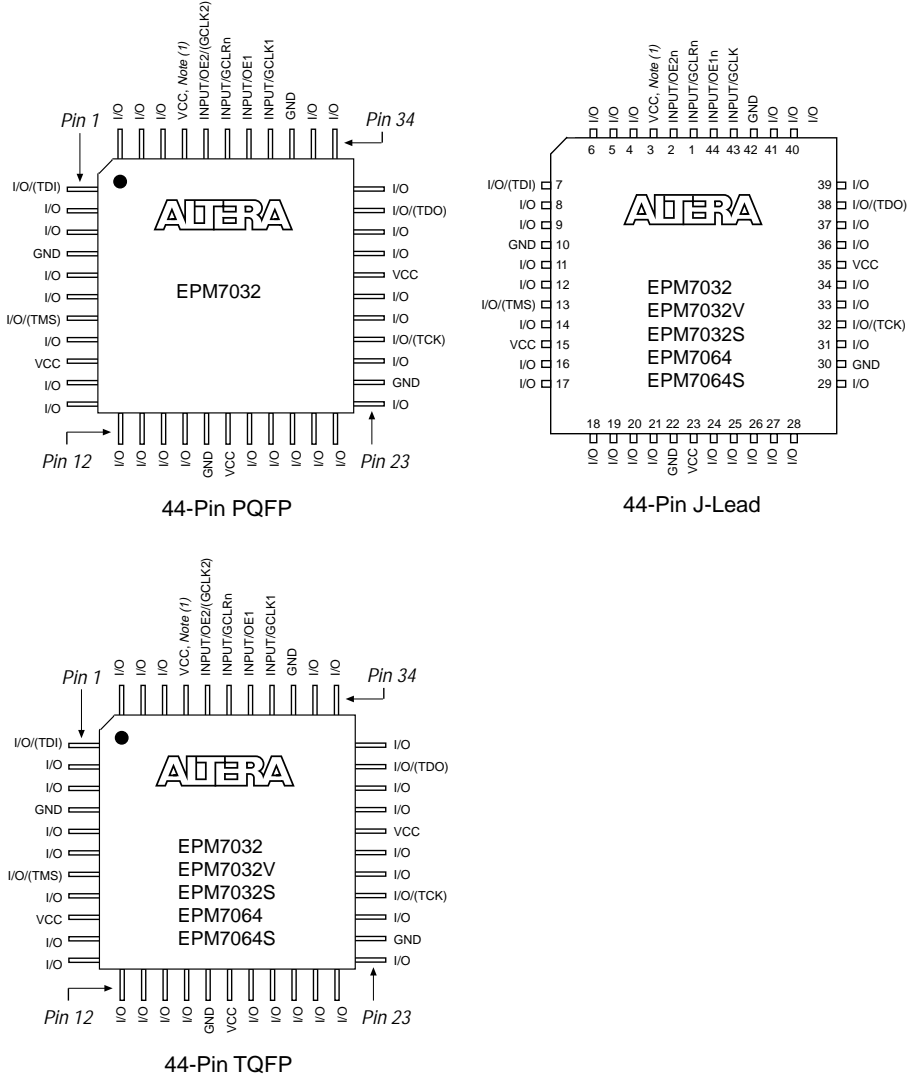

Note:

(1) This pin is a power-down pin (PDn) for the EPM7032V device.

Figure 18. 68-Pin Package Pin-Out Diagram

Package outlines not drawn to scale. Pin functions shown in parentheses are for MAX 7000S devices only.

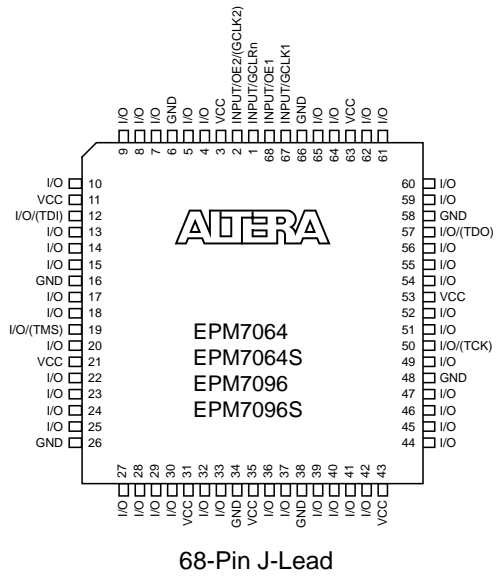
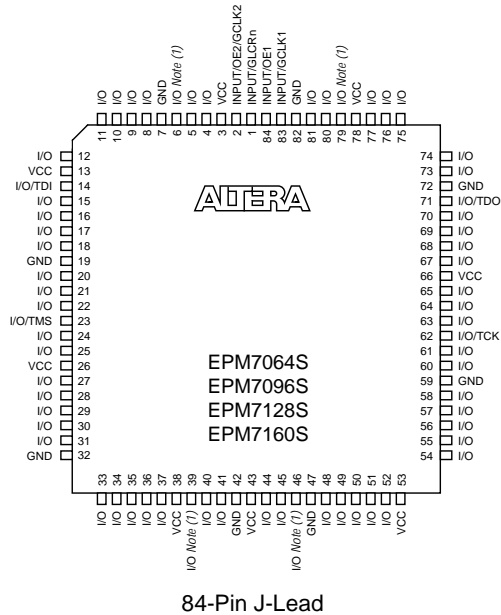

Figure 19. 84-Pin Package Pin-Out Diagram

Package outline not drawn to scale. Pin functions in parentheses are for MAX 7000S devices only.



Note:

- (1) Pins 6, 39, 46, and 79 are no-connect (N.C.) pins on EPM7096, EPM7096S, EPM7160E, and EPM7160S devices.

Figure 20. 100-Pin Package Pin-Out Diagram

Package outline not drawn to scale.

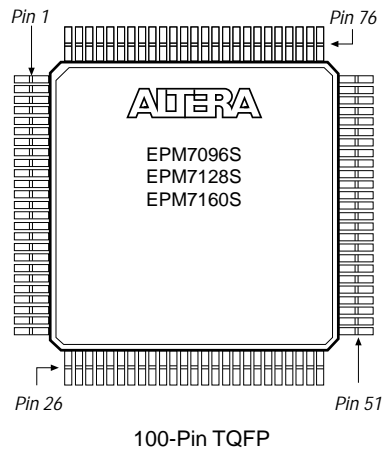
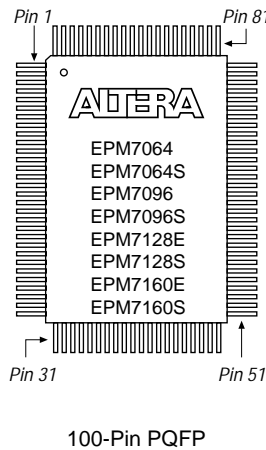

Figure 21. 160-Pin Package Pin-Out Diagram

Package outline not drawn to scale.

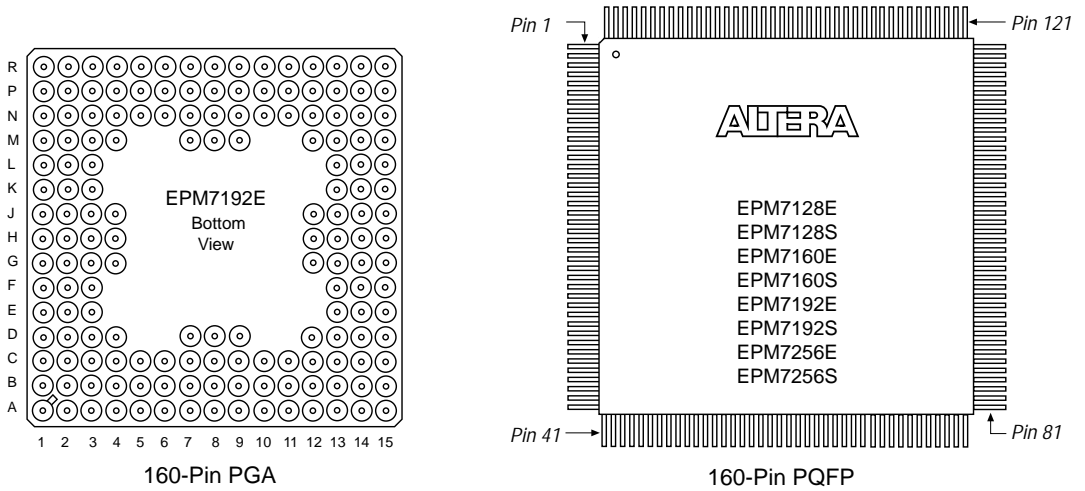

Figure 22. 192-Pin Package Pin-Out Diagram

Package outline not drawn to scale.

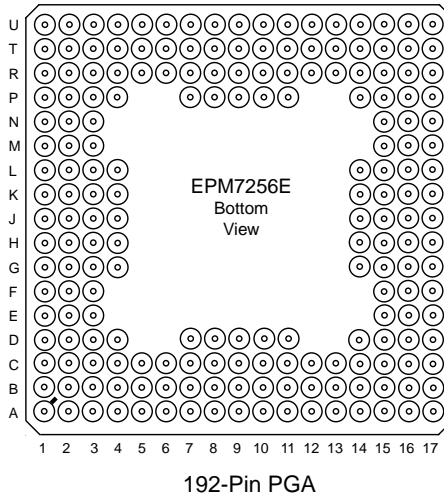
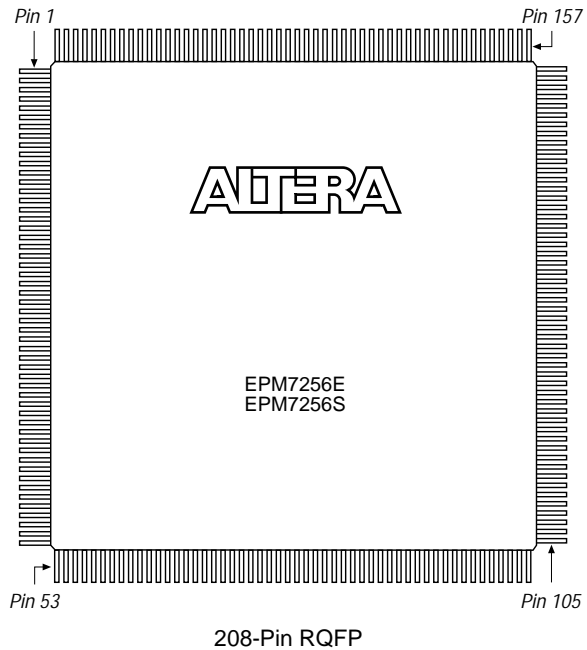

Figure 23. 208-Pin Package Pin-Out Diagram

Package outline not drawn to scale.



Copyright © 1995, 1996, 1997 Altera Corporation, 101 Innovation Drive,
San Jose, California 95134, USA, all rights reserved.

By accessing any information on this CD-ROM, you agree to be bound by
the terms of Altera's Legal Notice.

Preliminary Information

This data sheet supplement provides updated pin-out information for 100-pin EPM7128S devices in thin quad flat pack (TQFP) packages. This data sheet supplement should be used together with the *MAX 7000 Programmable Logic Device Family Data Sheet* in the Altera® **1996 Data Book**.

Tables 1 and 2 show updated pin-out information for the 100-pin EPM7128S device in the TQFP package. This data replaces the pin-out information provided in the Altera **1996 Data Book**.

Table 1. EPM7128S Dedicated Pin-Outs	
Dedicated Pin	100-Pin TQFP
INPUT/GCLK1	87
INPUT/GCLRn	89
INPUT/OE1	88
INPUT/OE2/GCLK2	90
TDI (1)	4
TMS (1)	15
TCK (1)	62
TDO (1)	73
GND	11, 26, 38, 43, 59, 74, 86, 95
VCCINT (5.0 V only)	39, 91
VCCIO (3.3 V or 5.0 V)	3, 18, 34, 51, 66, 82
No Connect (N.C.)	–
Total User I/O Pins	80

Table 2. EPM7128S I/O Pin-Outs (Part 1 of 2)

MC	LAB	100-Pin TQFP	MC	LAB	100-Pin TQFP
1	A	2	17	B	14
2	A	–	18	B	–
3	A	1	19	B	13
4	A	–	20	B	–
5	A	100	21	B	12
6	A	99	22	B	10
7	A	–	23	B	–
8	A	98	24	B	9
9	A	97	25	B	8
10	A	–	26	B	–
11	A	96	27	B	7
12	A	–	28	B	–
13	A	94	29	B	6
14	A	93	30	B	5
15	A	–	31	B	–
16	A	92	32	B	4 (1)
33	C	25	49	D	37
34	C	–	50	D	–
35	C	24	51	D	36
36	C	–	52	D	–
37	C	23	53	D	35
38	C	22	54	D	33
39	C	–	55	D	–
40	C	21	56	D	32
41	C	20	57	D	31
42	C	–	58	D	–
43	C	19	59	D	30
44	C	–	60	D	–
45	C	17	61	D	29
46	C	16	62	D	28
47	C	–	63	D	–
48	C	15 (1)	64	D	27

Table 2. EPM7128S I/O Pin-Outs (Part 2 of 2)

MC	LAB	100-Pin TQFP	MC	LAB	100-Pin TQFP
65	E	40	81	F	52
66	E	–	82	F	–
67	E	41	83	F	53
68	E	–	84	F	–
69	E	42	85	F	54
70	E	44	86	F	55
71	E	–	87	F	–
72	E	45	88	F	56
73	E	46	89	F	57
74	E	–	90	F	–
75	E	47	91	F	58
76	E	–	92	F	–
77	E	48	93	F	60
78	E	49	94	F	61
79	E	–	95	F	–
80	E	50	96	F	62 (1)
97	G	63	113	H	75
98	G	–	114	H	–
99	G	64	115	H	76
100	G	–	116	H	–
101	G	65	117	H	77
102	G	67	118	H	78
103	G	–	119	H	–
104	G	68	120	H	79
105	G	69	121	H	80
106	G	–	122	H	–
107	G	70	123	H	81
108	G	–	124	H	–
109	G	71	125	H	83
110	G	72	126	H	84
111	G	–	127	H	–
112	G	73 (1)	128	H	85

Note to tables:

- (1) This pin may function as either a Joint Test Action Group (JTAG) port or a user I/O pin. If the device is configured to use the JTAG ports for boundary-scan testing or for in-system programmability (ISP), this pin is not available as a user I/O pin.



2610 Orchard Parkway
San Jose, CA 95134-2020
(408) 894-7000
Applications Hotline:
(800) 800-EPLD
Customer Marketing:
(408) 894-7104
Literature Services:
(888) 3-ALTERA

Altera, MAX, MAX 7000, MAX 7000S, and EPM7128S are registered trademarks of Altera Corporation. The following are trademarks of Altera Corporation: MAX+PLUS II, AHDL, and FLEX 10K. Altera acknowledges the trademarks of other organizations for their respective products or services mentioned in this document. Altera products are protected under numerous U.S. and foreign patents and pending applications, maskwork rights, and copyrights. Altera warrants performance of its semiconductor products to current specifications in accordance with Altera's standard warranty, but reserves the right to make changes to any products and services at any time without notice. Altera assumes no responsibility or liability arising out of the application or use of any information, product, or service described herein except as expressly agreed to in writing by Altera Corporation. Altera customers are advised to obtain the latest version of device specifications before relying on any published information and before placing orders for products or services.

Copyright © 1996 Altera Corporation. All rights reserved.



I.S. EN ISO 9001



MAX 7000 Programmable Logic Device Family

March 1997, ver. 4.2

Data Sheet Supplement

Preliminary Information

This data sheet supplement provides pin-out information for EPM7064S, EPM7096S, and EPM7160S devices in 100-pin thin quad flat pack (TQFP) packages. This data sheet supplement must be used together with the *MAX 7000 Programmable Logic Device Family Data Sheet* in the Altera® **1996 Data Book**.

Tables 1 through 6 provide pin-out information for EPM7064S, EPM7096S, and EPM7160S devices.

Table 1. EPM7064S Dedicated Pin-Outs

Pin Name	100-Pin TQFP
INPUT/GCLK1	87
INPUT/GCLRn	89
INPUT/OE1	88
INPUT/OE2/GCLK2	90
TDI, <i>Note (1)</i>	4
TMS, <i>Note (1)</i>	15
TCK, <i>Note (1)</i>	62
TDO, <i>Note (1)</i>	73
GNDINT	38, 86
GNDIO	11, 26, 43, 59, 74, 95
VCCINT (5.0 V Only)	39, 91
VCCIO (3.3 V or 5.0 V)	3, 18, 34, 51, 66, 82
No Connect (N.C.)	1, 2, 5, 7, 22, 24, 27, 28, 49, 50, 53, 55, 70, 72, 77, 78
Total User I/O Pins	64

Table 2. EPM7064S I/O Pin-Outs

MC	LAB	100-Pin TQFP	MC	LAB	100-Pin TQFP
1	A	14	17	B	37
2	A	13	18	B	36
3	A	12	19	B	35
4	A	10	20	B	33
5	A	9	21	B	32
6	A	8	22	B	31
7	A	6	23	B	30
8	A	4 (1)	24	B	29
9	A	100	25	B	25
10	A	99	26	B	23
11	A	98	27	B	21
12	A	97	28	B	20
13	A	96	29	B	19
14	A	94	30	B	17
15	A	93	31	B	16
16	A	92	32	B	15 (1)
33	C	40	49	D	63
34	C	41	50	D	64
35	C	42	51	D	65
36	C	44	52	D	67
37	C	45	53	D	68
38	C	46	54	D	69
39	C	47	55	D	71
40	C	48	56	D	73 (1)
41	C	52	57	D	75
42	C	54	58	D	76
43	C	56	59	D	79
44	C	57	60	D	80
45	C	58	61	D	81
46	C	60	62	D	83
47	C	61	63	D	84
48	C	62 (1)	64	D	85

Table 3. EPM7096S Dedicated Pin-Outs

Pin Name	100-Pin TQFP
INPUT/GCLK1	87
INPUT/GCLRn	89
INPUT/OE1	88
INPUT/OE2/GCLK2	90
TDI, <i>Note (1)</i>	4
TMS, <i>Note (1)</i>	15
TCK, <i>Note (1)</i>	62
TDO, <i>Note (1)</i>	73
GNDINT	38, 86
GNDIO	11, 26, 43, 59, 74, 95
VCCINT (5.0 V Only)	39, 91
VCCIO (3.3 V or 5.0 V)	3, 18, 34, 51, 66, 82
No Connect (N.C.)	7, 22, 35, 42, 55, 70, 83, 94
Total User I/O Pins	72

Table 4. EPM7096S I/O Pin-Outs (Part 1 of 2)

MC	LAB	100-Pin TQFP	MC	LAB	100-Pin TQFP
1	A	6	17	B	21
2	A	–	18	B	–
3	A	5	19	B	20
4	A	4 <i>(1)</i>	20	B	19
5	A	2	21	B	17
6	A	1	22	B	16
7	A	–	23	B	–
8	A	100	24	B	15 <i>(1)</i>
9	A	99	25	B	14
10	A	–	26	B	–
11	A	98	27	B	13
12	A	97	28	B	12
13	A	96	29	B	10
14	A	93	30	B	9
15	A	–	31	B	–
16	A	92	32	B	8

Table 4. EPM7096S I/O Pin-Outs (Part 2 of 2)

MC	LAB	100-Pin TQFP	MC	LAB	100-Pin TQFP
33	C	37	49	D	40
34	C	–	50	D	–
35	C	36	51	D	41
36	C	33	52	D	44
37	C	32	53	D	45
38	C	31	54	D	46
39	C	–	55	D	–
40	C	30	56	D	47
41	C	29	57	D	48
42	C	–	58	D	–
43	C	28	59	D	49
44	C	27	60	D	50
45	C	25	61	D	52
46	C	24	62	D	53
47	C	–	63	D	–
48	C	23	64	D	54
65	E	56	81	F	71
66	E	–	82	F	–
67	E	57	83	F	72
68	E	58	84	F	73 (1)
69	E	60	85	F	75
70	E	61	86	F	76
71	E	–	87	F	–
72	E	62 (1)	88	F	77
73	E	63	89	F	78
74	E	–	90	F	–
75	E	64	91	F	79
76	E	65	92	F	80
77	E	67	93	F	81
78	E	68	94	F	84
79	E	–	95	F	–
80	E	69	96	F	85

Table 5. EPM7160S Dedicated Pin-Outs

Pin Name	100-Pin TQFP
INPUT/GCLK1	87
INPUT/GCLRn	89
INPUT/OE1	88
INPUT/OE2/GCLK2	90
TDI, <i>Note (1)</i>	4
TMS, <i>Note (1)</i>	15
TCK, <i>Note (1)</i>	62
TDO, <i>Note (1)</i>	73
GNDINT	38, 86
GNDIO	11, 26, 43, 59, 74, 95
VCCINT (5.0 V Only)	39, 91
VCCIO (3.3 V or 5.0 V)	3, 18, 34, 51, 66, 82
No Connect (N.C.)	–
Total User I/O Pins	80

Table 6. EPM7160S I/O Pin-Outs (Part 1 of 3)

MC	LAB	100-Pin TQFP	MC	LAB	100-Pin TQFP
1	A	100	17	B	9
2	A	–	18	B	–
3	A	99	19	B	8
4	A	–	20	B	–
5	A	–	21	B	–
6	A	98	22	B	7
7	A	–	23	B	–
8	A	97	24	B	6
9	A	96	25	B	5
10	A	–	26	B	–
11	A	94	27	B	4 <i>(1)</i>
12	A	–	28	B	–
13	A	–	29	B	–
14	A	93	30	B	2
15	A	–	31	B	–
16	A	92	32	B	1

Table 6. EPM7160S I/O Pin-Outs (Part 2 of 3)

MC	LAB	100-Pin TQFP	MC	LAB	100-Pin TQFP
33	C	19	49	D	–
34	C	–	50	D	–
35	C	17	51	D	28
36	C	–	52	D	–
37	C	–	53	D	27
38	C	16	54	D	25
39	C	–	55	D	–
40	C	15 (1)	56	D	24
41	C	10	57	D	–
42	C	–	58	D	–
43	C	12	59	D	23
44	C	–	60	D	–
45	C	–	61	D	22
46	C	13	62	D	21
47	C	–	63	D	–
48	C	14	64	D	20
65	E	–	81	F	–
66	E	–	82	F	–
67	E	37	83	F	40
68	E	–	84	F	–
69	E	36	85	F	41
70	E	35	86	F	42
71	E	–	87	F	–
72	E	33	88	F	44
73	E	–	89	F	–
74	E	–	90	F	–
75	E	32	91	F	45
76	E	–	92	F	–
77	E	31	93	F	46
78	E	30	94	F	47
79	E	–	95	F	–
80	E	29	96	F	48

Table 6. EPM7160S I/O Pin-Outs (Part 3 of 3)

MC	LAB	100-Pin TQFP	MC	LAB	100-Pin TQFP
97	G	–	113	H	58
98	G	–	114	H	–
99	G	49	115	H	60
100	G	–	116	H	–
101	G	50	117	H	–
102	G	52	118	H	61
103	G	–	119	H	–
104	G	53	120	H	62 (1)
105	G	–	121	H	67
106	G	–	122	H	–
107	G	54	123	H	65
108	G	–	124	H	–
109	G	55	125	H	–
110	G	56	126	H	64
111	G	–	127	H	–
112	G	57	128	H	63
129	I	68	145	J	77
130	I	–	146	J	–
131	I	69	147	J	78
132	I	–	148	J	–
133	I	–	149	J	–
134	I	70	150	J	79
135	I	–	151	J	–
136	I	71	152	J	80
137	I	72	153	J	81
138	I	–	154	J	–
139	I	73 (1)	155	J	83
140	I	–	156	J	–
141	I	–	157	J	–
142	I	75	158	J	84
143	I	–	159	J	–
144	I	76	160	J	85

Note to tables:

- (1) This pin can function as either a JTAG port or a user I/O pin. If the device is programmed to use the JTAG ports, this pin is not available as a user I/O pin.



2610 Orchard Parkway
San Jose, CA 95134-2020
(408) 544-7000
<http://www.altera.com>
Applications Hotline:
(800) 800-EPLD
Customer Marketing:
(408) 894-7104
Literature Services:
(888) 3-ALTERA
lit_req@altera.com

Altera, MAX, MAX 7000, EPM7064S, EPM7096S, and EPM7160S are trademarks and/or service marks of Altera Corporation in the United States and other countries. Altera acknowledges the trademarks of other organizations for their respective products or services mentioned in this document. Altera products are protected under numerous U.S. and foreign patents and pending applications, maskwork rights, and copyrights. Altera warrants performance of its semiconductor products to current specifications in accordance with Altera's standard warranty, but reserves the right to make changes to any products and services at any time without notice. Altera assumes no responsibility or liability arising out of the application or use of any information, product, or service described herein except as expressly agreed to in writing by Altera Corporation. Altera customers are advised to obtain the latest version of device specifications before relying on any published information and before placing orders for products or services.

Copyright © 1997 Altera Corporation. All rights reserved.

