

CHC[®] CTS-112R4

User Manual



Version 1.0
English

Make your work more efficient

Table of content

1.	Features	5
2.	Cautions	6
3.	Safety guide	7
4.	Description of the instrument	8
4.1.	Instrument components	8
4.2.	Keyboard description	9
4.3.	Functional keys	11
4.4.	Star (★) key mode.....	13
5.	Description of the instrument	14
5.1.	Power On/Off.....	14
5.2.	Setting of tilt correction on vertical and horizontal angles	14
5.3.	Setting distance measurement mode.....	16
5.4.	Setting of tilt correction on vertical and horizontal angles	16
5.5.	Reflecting signal	17
5.6.	Setting atmospheric correction	18
5.6.1.	Setting the atmospheric correction value directly.....	18
5.6.2.	Calculating the atmospheric correction based on temperature and pressure...19	
5.7.	Correction on atmospheric refraction error and earth curvature.....	20
5.8.	Setting minimum reading of setting angle/distance	20
5.9.	Setting auto power OFF	22
5.10.	Setting instrument constant	23
5.11.	Select a code file	24
6.	Preparation for measurements	25
6.1.	Unpacking and storage of instrument	25
6.2.	Instrument setup	25
6.2.1.	Leveling and Centering the Instrument by plumb bob	25
6.2.2.	Centering by using the laser plummet.....	26
6.3.	Loading, unloading, charging the battery and its information	27
6.4.	Reflecting prism	28
6.5.	Mounting and dismounting instrument from tribrach	28
6.6.	Eyepiece adjustment and collimating object	29
6.7.	Method of inputting, alphanumeric characters	29
7.	Angles measurements	31
7.1.	Measuring horizontal and vertical angles.....	31
7.2.	Shift the horizontal angle (right/left).....	32
7.3.	Setting horizontal angle	32
7.3.1.	Setting by [HOLD].....	32
7.3.2.	Setting by Inputting through the Keyboard	33
7.4.	Shift between V angle and V%.....	34
7.5.	Repetitious angle measurement.....	35
7.6.	Shift between azimuth and vertical angle	37

8.	Distance measurements	38
8.1.	Distance measurements	38
8.2.	Setting measurement mode	39
8.3.	Stakeout	40
8.4.	Offset measurement	41
8.4.1.	Angle offset	41
8.4.2.	Distance offset	43
8.4.3.	Plane offset	45
8.4.4.	Column offset	47
9.	Coordinates measurements	50
9.1.	Procedure of coordinates measurements	50
9.2.	Setting coordinates of occupied point	52
9.3.	Setting the instrument height	53
9.4.	Setting the target height	54
10.	Data collection	55
10.1.	Operation procedure	55
10.2.	Selecting a file for data collection	56
10.3.	Occupied point and backsight point	56
10.3.1.	Example for setting the occupied point	57
10.4.	Data collect offset measurement mode	57
10.4.1.	Angle offset measurement	58
10.4.2.	Distance offset measurement	60
10.4.3.	Plane offset measurement	61
10.4.4.	Column offset measurement	64
10.5.	Setting config of data collection	66
11.	Stakeout	67
11.1.	Stakeout procedure	67
11.2.	Preparation	67
11.2.1.	Setting the grid factor	67
11.2.2.	Selecting coordinate data file	68
11.2.3.	Setting occupied point	68
11.2.4.	Setting backsight point	69
11.3.	Setting a new point	70
11.3.1.	Side shot method	70
11.3.2.	Resection method	71
12.	Measurement program mode	75
12.1.	Remote height measurement (REM)	75
12.1.1.	Known prism height (e.g. H = 1.3 m)	75
12.1.2.	When prism height is unknown	77
12.2.	Tie distance	78
12.2.1.	MLM-1 (A-B, A-C)	79
12.2.2.	Using coordinate file	81
12.3.	Set Z coordinate of occupied point	82

12.3.1. Set Z coordinate occupied point using coordinate data file	82
12.3.2. Set Z coordinate of occupied point without coordinate data file.....	84
12.4. Area calculation	85
12.4.1. Area calculation from coordinate data file	85
12.4.2. Change the display unit	86
12.5. Measurement REOM point to line.....	87
13. Parameters	89
14. Memory management	90
14.1. File maintains.....	90
14.1.1. Setting the atmospheric correction value directly	90
14.1.2. Create a new file	91
14.1.3. Renaming a file	91
14.1.4. Delete a file.....	92
14.2. File output.....	92
14.3. Data transfer	93
14.4. Load data	94
15. Check and adjustment	95
15.1. Bubble level	95
15.2. Circular level	95
15.3. Adjustment of reticle	95
15.4. Perpendicularity of the line of sight to horizontal axis (2C)	96
15.5. Vertical index difference compensation	98
15.6. Adjustments of vertical index difference (I angle) and vertical angle 0 datum.....	98
15.7. Transverse axis error compensation adjustment.....	100
15.8. Optical plummet	101
15.9. Instrument constant (K).....	102
15.10. Parallel between line of sight and emitting photoelectric axis	103
15.11. Reflectorless EDM.....	103
15.12. Tribrach leveling screw	104
15.13. Related parts for reflector	104

1. Features

Makes fieldwork easier

Dual face keyboards with buttons illumination to minimize mistakes provides optimum viewing and convenience under any environmental conditions. Starkey button [★] immediately brings up necessary functions. Built-in laser plummet is equipped for quick instrument setup in all lighting conditions. Enables cable-free connection like mini-USB, SD as well as serial ports.

Better EDM performance

The CTS-112R 4 is one of the fastest total station in his class, with a distance measurement speed of 0.3 seconds. Reflectorless range is up to 400 m and distance measurement to single prism is 5000 m.

Absolute encoding disk

With absolute encoding disk, you can start your work directly as the instrument is powered on. Azimuth angle will be saved even if the power is off incidentally in the job.

Large memory size

Internal memory can store 30 000 points, however external SD card supports maximum 32 GB memory that can record 245 760 000 points.

Special surveying programs

Besides of ordinary surveying programs, such series of total station also has special surveying programs, such as remote height measurement, offset measurement, remote distance measurement, stake out, resection, area calculation, road design and stake out, etc., which are enough to meet the needs of professional measurement and surveying measurement.

2. Cautions



CAUTION

- 1) Do not collimate the objective lens direct to sunlight without a filter.
- 2) Do not store the instrument in high and low temperature to avoid the sudden or great change of temperature.
- 3) When the instrument is not in use, place it in the case and avoid shock, dust and humidity.
- 4) If there is great difference between the temperature in work site and that in store place, you should leave the instrument in the case till it adapts to the temperature of environment.
- 5) If the instrument has not been used for a long time, you should remove the battery for separate storage. The battery should be charged once a month.
- 6) When transporting the instrument should be placed in carrying case, it is recommended that cushioned material should be used around the case for support.
- 7) For less vibration and better accuracy, the instrument should be set up on a wooden tripod rather than an aluminum tripod.
- 8) Clean exposed optical parts with degreased cotton or less tissue only!
- 9) Clean the instrument surface with a woolen cloth after use. If it gets wet, dry it immediately.
- 10) Before opening, inspect the power, functions and indications of the instrument as well as initial setting and correction parameters.
- 11) Unless the user is a maintenance specialist, do not attempt to disassemble the instrument by yourself even if you find the instrument abnormal.
- 12) The CTS-112R4 is reflectorless total station and emits visible laser. Do not shoot at eyes.

3. Safety guide

**WARNING**

The total station is equipped with an EDM of a laser grade of 3R/a. It is verified by the following labels. On the vertical tangent screw sticks an indication label "CLASS III LASER PRODUCT". A similar label is stick on the opposite side. This product is classified as Class 3R laser product, which accords to the following standards. IEC60825-1:2001 "SAFETY OF LASER PRODUCTS". Class 3R/a laser product: It is harmful to observe laser beam continuously. User should avoid sighting the laser at the eyes. It can reach 5 times the emitting limit of Class2/II with a wavelength of 400 mm-700 mm.

**WARNING**

Continuously looking straight at the laser beam is harmful.

Prevention:

Do not stare at the laser beam or point the laser beam to other's eyes. Reflected laser beam is a valid measurement to the instrument.

**WARNING**

When the laser beam emits on prism, mirror, metal surface, window, etc., it is dangerous to look straight at the reflex.

Prevention:

Do not stare at the object which reflects the laser beam. When the laser is switched on (under EDM mode), do not look at it on the optical path or near the prism. It is only allowed to observe the prism with the telescope of total station.

**WARNING**

Improper operation on laser instrument of Class 3R will bring dangers.

Prevention:

To avoid being harmed, each user is required to take safety precautions, and take everything under control within the distance that would incur dangers (according to IEC60825-1:2001).

The following shows the explanation related to the key sections of the Standard. Laser instrument of Class 3R is applicable outdoors and in construction field (measurement, defining lines, leveling).

- Only those persons who are trained with related course and authenticated can install, adjust, and operate this kind of laser instrument.
- Stand related warning symbols in the scale of use.
- Prevent any person to look straight at or use optical instrument to observe the laser beam.
- To prevent the harm caused by laser, block the laser beam at the end of the working route.
- When the laser beam exceeds the limit area (harmful distance) and when there are motivating persons, stopping the laser beam is a must.
- The optical path of the laser should be set higher or lower than the line of sight.
- When the laser instrument is not in use, take care of it properly. The person who is not authenticated is not allowed to use.
- Prevent the laser beam from irradiating plane mirror, metal surface, window, etc.; especially beware of the surface of plane mirror and concave mirror.



Harmful distance means the maximum distance between the start point and the point which the laser is weakened to a degree that doesn't harm people.

4. Description of the instrument

4.1. Instrument components

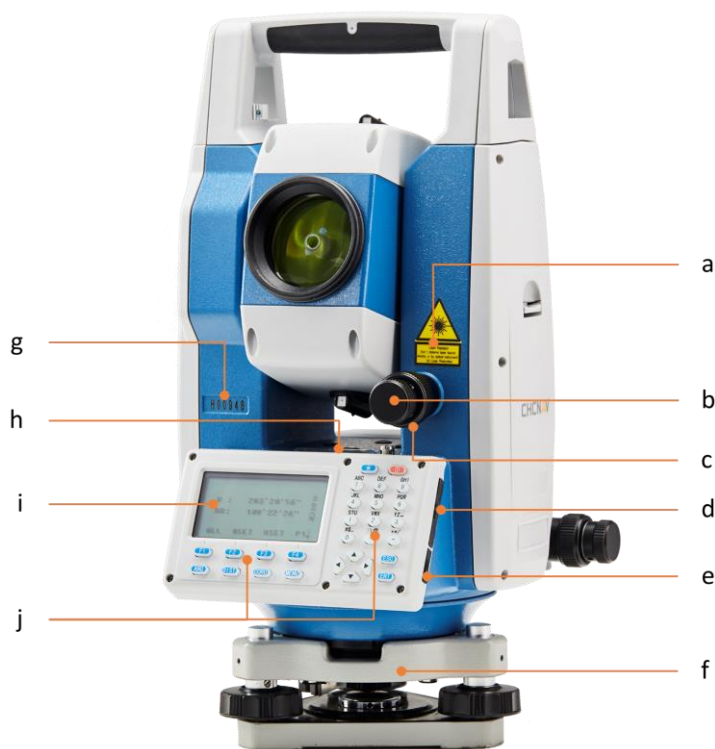

- a) Laser class label
- b) Vertical drive
- c) Vertical clamp
- d) SD card port
- e) Mini-USB interface
- f) Tribrach
- g) Instrument serial number
- h) Bubble level
- i) I Face display
- j) I Face keyboard

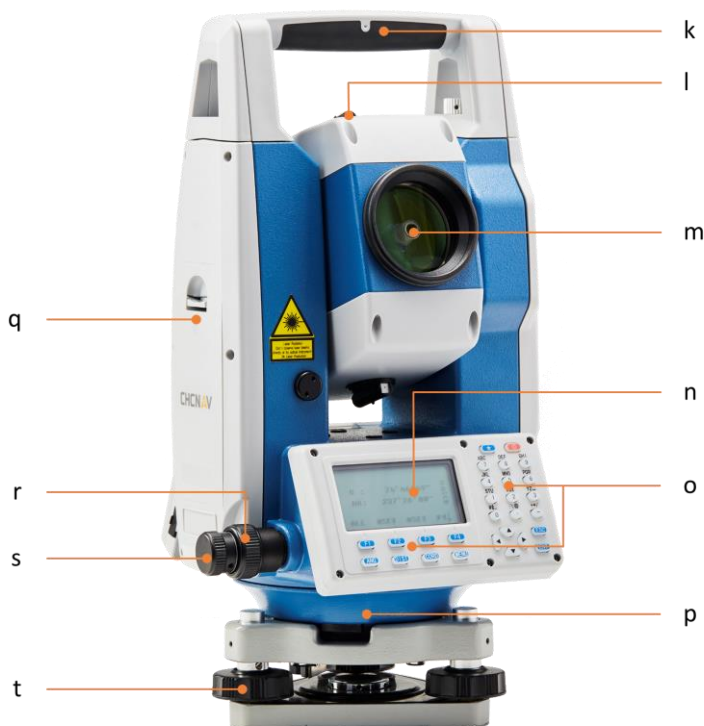

- k) Carrying handle with mounting screw
- l) Optical sight
- m) Objective with integrated EDM
- n) II Face display
- o) II Face keyboard
- p) Laser plummet
- q) Battery cover
- r) Horizontal clamp
- s) Horizontal drive
- t) Leveling screw

4.2. Keyboard description

When total station power on, it will show angel measurement mode screen (three-page menu).

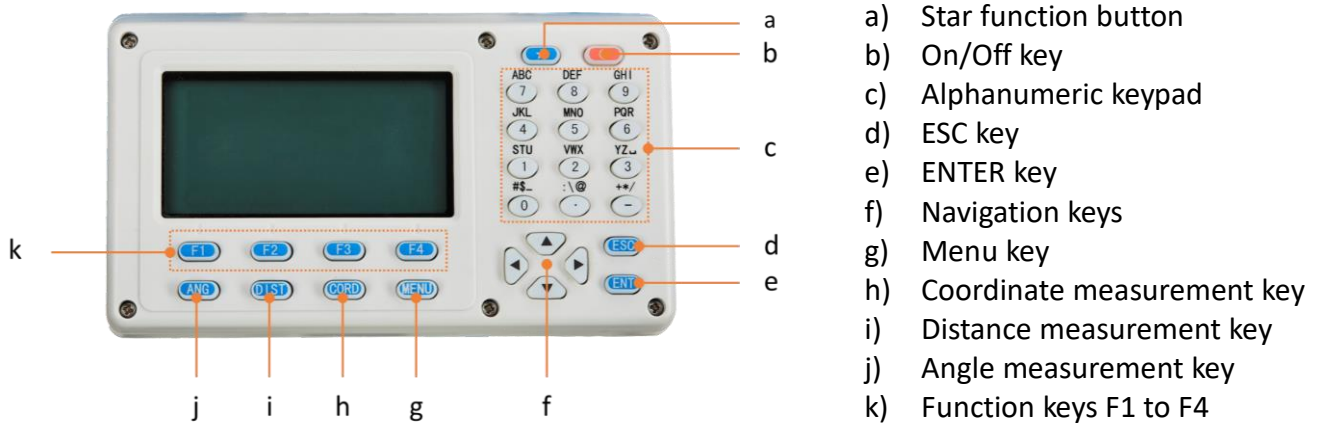

Keys

Device	Description
	On / Off button. Switches the instrument on or off.
	Star function button. Choose reflector type, plummet intensity, crosshair and display illumination.
	Angle measurement key. Angle measurement mode functionality.
	Distance measurement key. Distance measurement mode functionality.
	Coordinate measurement key. Coordinates mode functionality.
	Menu key. Including manage known points, stakeout, storage manage, device version and settings.
	Navigation keys.
	Esc key. Exit from the current interface.
	Enter key. Confirms an entry and continues to the next field.
	Function keys that are assigned the variable functions displayed at the bottom of the screen.
	Alphanumeric keypad for entry of text and numerical values.

Displayed symbols

Symbol	Description
V%:	vertical angle (slope)
HR:	horizontal angle(right)
HL:	horizontal angle(left)
HD:	horizontal distance
VD:	vertical distance
SD:	slop distance
N:	coordinate N
E:	coordinate E
Z:	coordinate Z
*	EDM (electronic distance meter) is under operation.
m:	meter as the unit
ft:	foot as the unit
fi:	foot and inch as the unit

4.3. Functional keys

ANGLE MEASUREMENT MODE (3 interface menus)

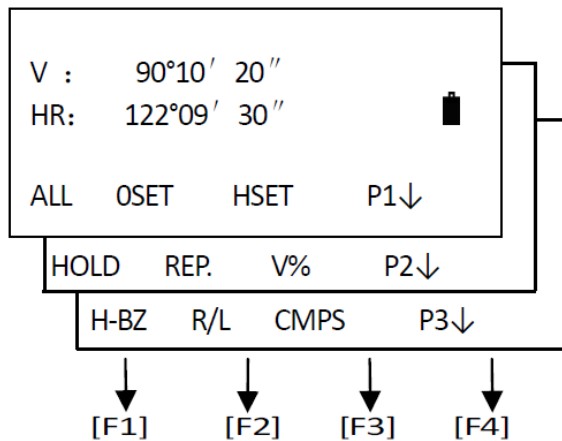

Page1

ALL: Start angle measurement and save the results in respective job. (Measurement files and coordinates files are selected in DATA COLLECT menu.)

OSET: Set horizontal angle to 0 degree

HSET: Input a horizontal angle by keyboard

P1↓: Display the soft key functions in page2

Page2

HOLD: Lock the reading of horizontal angle

REP.: Repeat measuring on horizontal angle

V%: Shift between vertical angle/slope percentage

P2↓: Display the soft key functions on page3

Page3

H-BZ: Set ON/OFF for the beep when the horizontal angle reaches 0°, 90°, 180°, 270°

R/L: Shift between right/left angle of horizontal angle

CMPS: Shift the display format of vertical angle (vertical angle/azimuth angle)

P3↓: Display the soft key functions on page1

DISTANCE MEASUREMENT MODE (2 interface menus)

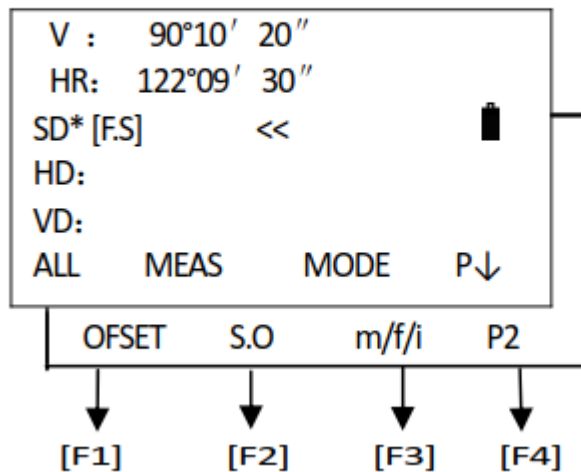

Page1

ALL: Start distance measurement and save the results in respective job. (Measurement files and coordinates files are selected in DATA COLLECT menu.)

MEAS: Start distance measurement

MODE: Shift the distance measurement modes (F.S/F.N/F.R/T.R)

P1↓: Display the soft key functions in page2

Page2

OFFSET: Offset measurement mode

S.O: Distance stake out mode

m/f/i: Set distance unit (meter/feet/feet. inch)

P2↓: Display the soft key functions in page1

COORDINATES MEASUREMENT MODE (3 interface menus)

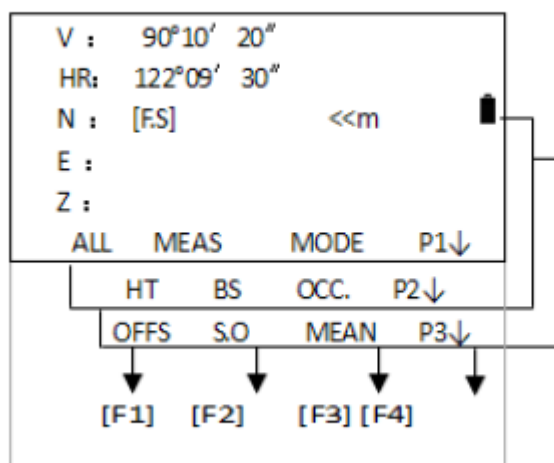

Page1

ALL: Start coordinates measurement and save the results in respective job. (Measurement files and coordinates files are selected in DATA COLLECT menu.)

MEAS: Start coordinates measurement

MODE: Shift the distance measurement modes (F.S/F.N/F.R/T.R)

P1↓: Display the soft key functions in page2

Page2

HT: Set the instrument height and target height

BS: Set the coordinates of the backsight point

OCC.: Set the coordinates of the occupied point

P2↓: Display the soft key functions in page3

Page3

OFFS: Offset measurement mode

S.O: Coordinates stake out mode

MEAN: Set the measuring time of fine measurement

P3↓: Display the soft key functions in page1

4.4. Star (★) key mode

Press ★, the screen will show:

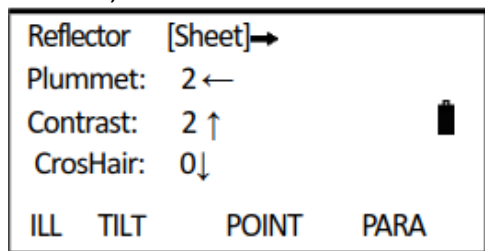

Press Star key [★], you can set the below items:

- 1) Contrast: Press [↓], you can adjust the contrast of the LCD.
- 2) Illumination:
Press [F1]: turn on the background light
Press [F1] again: turn off the background light
- 3) Tilt Compensation: press [F2] to enter to settings of tilt compensation. Press [F1] or [F3] to switch tilt sensor ON/OFF.
- 4) Reflector: Press [★] to set the reflector type. Press [→] every time to shift the reflector type among Prism/NON-P/Sheet.
- 5) Pointer: Press [F3] to activate the visible laser beam.
- 6) Parameter: Press [F4] to select "PARA", you can set the prism constant, PPM value, temperature and atmospheric pressure and check the reflecting signal.

5. Description of the instrument

5.1. Power On/Off

1) Turn on the power, the screen will show:

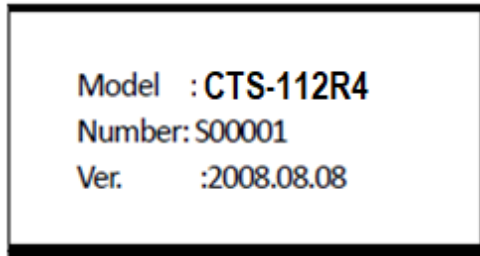

2) Insert a SD card, the instrument will start to detect the SD card.

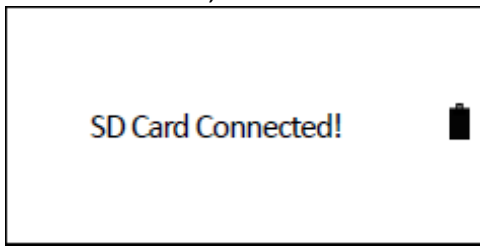

3) After inspection, you can enter to measurement mode automatically.

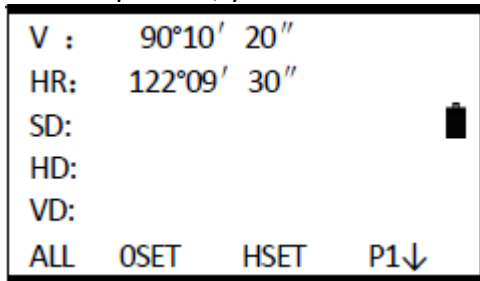

Hold [POWER] for 3 seconds to switch off the power.

5.2. Setting of tilt correction on vertical and horizontal angles

When activating the tilt sensor, it will show the correction value of vertical and horizontal angles because the instrument is not perfectly leveled. To ensure the measurement accuracy, the tilt sensor should be activated (single/dual axis), which will facilitate you to level the instrument better. When the tilt sensor interface appears, it needs to be leveled manually.

- The CTS-112R series can automatically correct the horizontal and vertical angle readings deviations which are caused by tilt of instrument's vertical axis on X and Y direction.
- The CTS-112R series provide 3 tilt correction modes: disable tilt sensor, X-ON (single axis) and XYON (dual axis). Dual axis compensation: correct the errors of horizontal angle caused by the index error of vertical angle and tilt of vertical axis. When it exceeds the limit, the tilt sensor interface will appear. User should level the instrument manually. Single axis compensation: correct the index error of vertical angle. When it exceeds the correction limit of vertical angle, the tilt sensor interface will appear.
- Disable tilt sensor: close the tilt compensator.

If the instrument operates under an unstable status or windy days, the vertical angle displays unstably. In such circumstances, the tilt sensor should be disabled, so that it will avoid the instrument from displaying error messages as well as abortion of measurement caused by the tilt sensor exceeding the correction limit.

- 1) Enter Star (★) key mode.

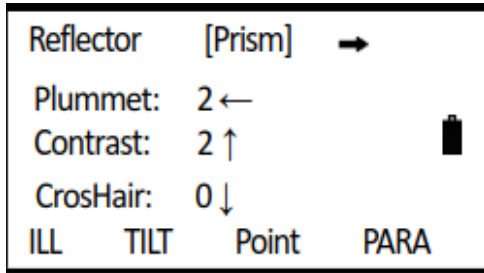

- 2) Press [F2] to enter to tilt correction settings.

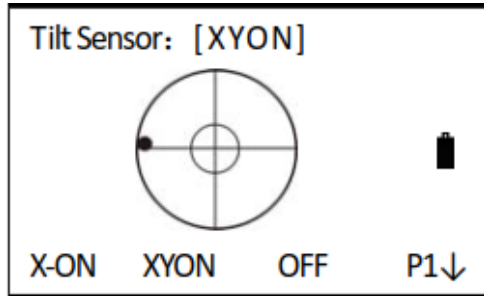

- 3) When the tilt of instrument exceeds the correction range, it needs leveling manually. Follow the steps described in "Instrument Setup" to center the black dot, as shown on the right. Single Axis: only corrects the vertical angle. Dual Axis: corrects vertical and horizontal angles.

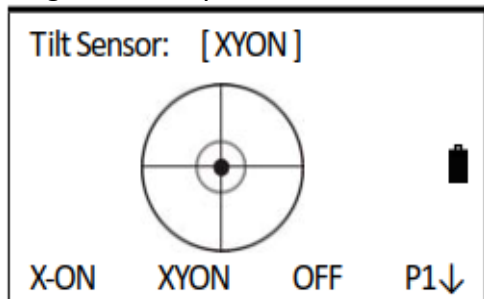

- 4) Press [F4] (↓) to display the tilt value on X (horizontal) and Y (vertical) direction. It needs leveling manually. Rotate the screws on the tribrach to level the instrument. Press [ESC], return to Star key mode. Press [F3] to disable the correction.

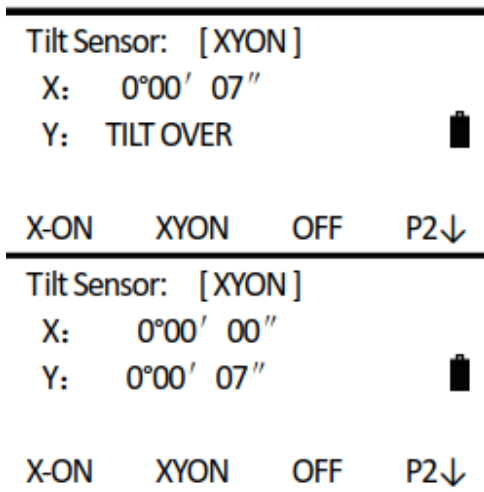

- 5) If the tilt sensor is disabled, press [F1] (X-ON) or [F2] (XYON) to activate the correction function.

5.3. Setting distance measurement mode

Total station CTS-112R series can adopt visible laser distance measurement and invisible IR distance measurement. Prism, NON-prism and reflecting sheet are selectable as reflector. User can set a mode according to the job requirement.

- 1) Enter Star (★) key mode.

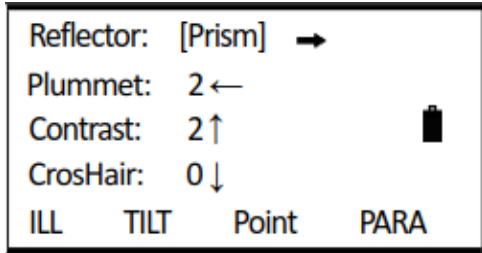

- 2) Press [MENU] to select the type of reflector. Press [MENU] every time to shift among Prism/ NON-P sheet. Press [ESC] to save the settings and return to measurement mode.

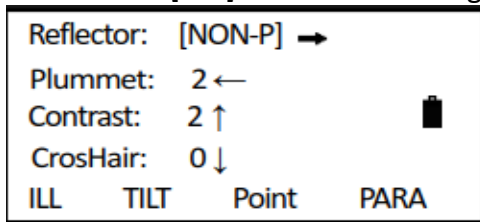

5.4. Setting of tilt correction on vertical and horizontal angles

When using prism as reflector, it is required to set the prism constant before measurement. As the prism constant is set, such constant will be maintained even after power off.

- 1) Enter to Star (★) key mode and press [F4] (PARA).

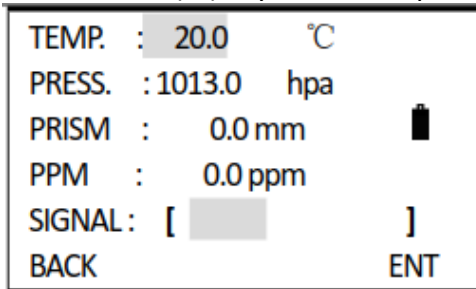

- 2) Press [▼] to move down to prism constant item.

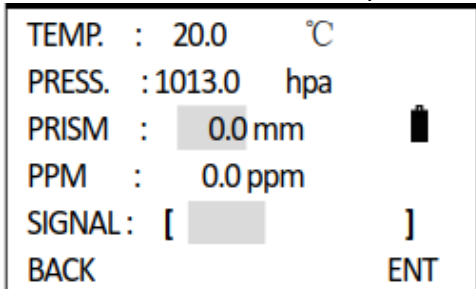

3) Input prism constant correction vale and press [F4] (ENT). Press [ESC] to return to Star key mode.

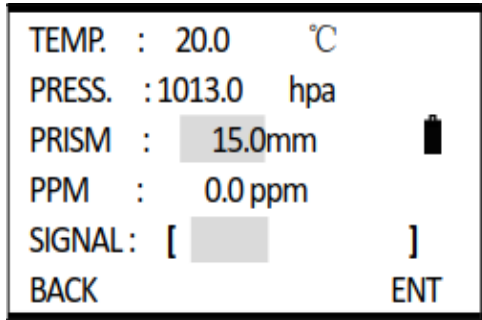

Refer to section 6.7 “Method of inputting, alphanumeric characters” to learn how to input numbers or characters. Inputting range: -99.9 mm to +99.9 mm Step length: 0.1 mm.

5.5. Reflecting signal

Reflecting signal function displays the intensity of EDM’s reflecting signal. It helps user to collimate the target in tough conditions. In circumstance that target is not easy to be found, this function will help you easily collimate the target.

1) Enter Star (★) key mode.

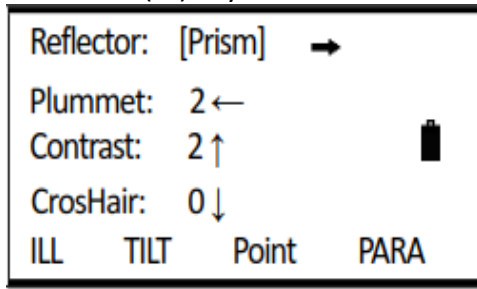

2) Press [F4] (PARA) to display the intensity (signal) of the reflecting light. It will show the intensity by a column.

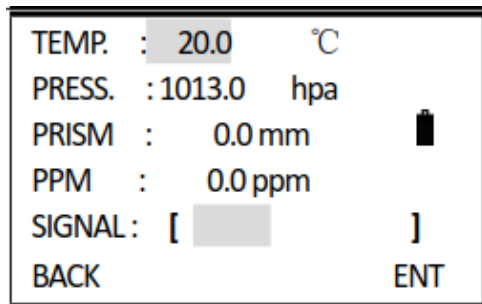

When receiving the reflecting light, the instrument will buzz. To disable the buzzer, refer to section 13 “Parameters”.

3) Press [ESC] to return to Star key mode.

5.6. Setting atmospheric correction

When during distance measurement, the result may be affected by atmospheric condition. To overcome the affection of the atmospheric condition, it is necessary to use make correction through atmospheric correction constant during distance measurement.

- Temperature: the temperature of the surrounding air.
- Pressure: the atmospheric pressure surrounding the instrument.
- PPM: the atmospheric correction calculated and estimated.

Standard atmospheric condition of total station CTS-112R series (i.e. the atmospheric condition when the atmospheric correction value is 0):

- Pressure: 1013hPa
- Temperature: 20°C

Calculation of atmospheric correction:

$$\text{PPM} = 278.44 - 0.294922 P / (1 + 0.003661T)$$

In the formula:

- Correction coefficient (unit: ppm)
- P: pressure (unit: hpa)
- T: temperature (unit: °C)



When the unit of atmospheric pressure is mmHg, follow this formula: 1 hPa = 0.75 mmHg

5.6.1. Setting the atmospheric correction value directly

Measure the temperature and press, then calculate the atmospheric correction value (PPM) through the atmospheric correction graph or the formula.

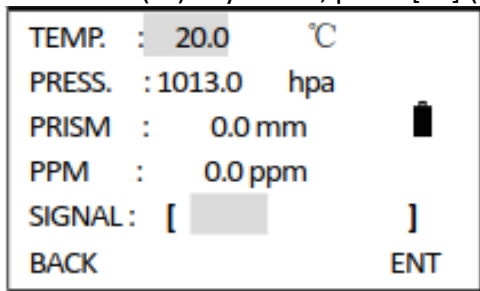

- 1) Enter Star (★) key mode, press [F4] (PARA).

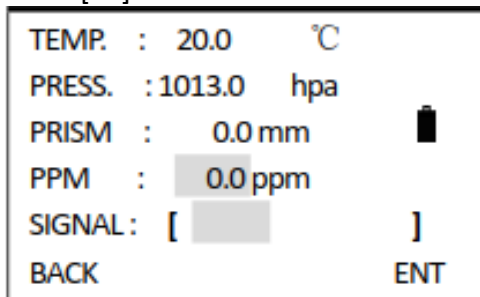

- 2) Press [▼] to move down to PPM item.



- 3) Input the atmospheric correction value, and press [F4] (ENT) to return to Star key mode.

TEMP. : 20.0	°C	
PRESS. : 1013.0	hpa	
PRISM : 0.0	mm	
PPM : 4.0	ppm	
SIGNAL : []
BACK		ENT
Reflector: [Prism] →		
Plummet: 2	←	
Contrast: 2	↑	
CrosHair: 0	↓	
ILL	TILT	Point PARA



Refer to 6.7 “Method of inputting, alphanumeric characters” to learn how to input numbers or characters. Inputting range: -99.9 mm to +99.9 mm Step length: 0.1 mm.

5.6.2. Calculating the atmospheric correction based on temperature and pressure

Measure the temperature and pressure of the surrounding air previously. E.g. temperature: +25°C, pressure: 1017.5 hPa

- 1) Enter Star (★) key mode.

TEMP. : 20.0	°C	
PRESS. : 1013.0	hpa	
PRISM : 0.0	mm	
PPM : 0.0	ppm	
SIGNAL : []
BACK		ENT

- 2) Press [F4] (PARA) to enter to parameter settings. Input the temperature and pressure values, the system will calculate the PPM value automatically according to the values you input.

TEMP. : 20.0	°C	
PRESS. : 1017.5	hpa	
PRISM : 0.0	mm	
PPM : 3.5	ppm	
SIGNAL : []
BACK		ENT

3) Press [F4] (ENT) to return to Star key mode.

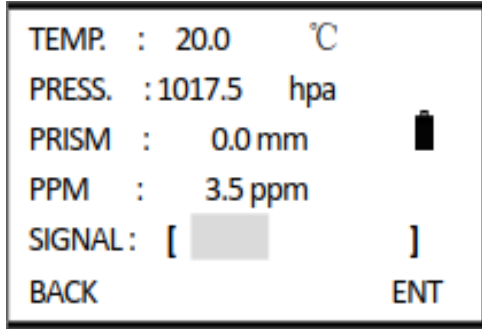

Refer to 6.7 “Method of inputting, alphanumeric characters” to learn how to input numbers or characters.

Inputting range of temperature: -30° +60°C (step: 0.1°C) or -22 +140°F (step: 0.1°F)

Inputting range of pressure: 560-1066 hPa (step: 0.1 hPa) or 420~800 mmHg (step length: 0.1 mmHg) or 16.5-31.5 inHg (step: 0.1 inHg)

If the PPM calculated according to temperature and press input is beyond ±999.9 ppm, the system will return to Step 2 automatically and you should input the value again.

5.7. Correction on atmospheric refraction error and earth curvature

During horizontal distance measurement and height difference measurement, the instrument corrects the atmospheric refraction error and earth curvature automatically. Formula of correction on atmospheric refraction error and earth curvature:

Horizontal distance after correction:

$$D=S * [\cos\alpha+ \sin\alpha * S * \cos\alpha (K-2) / 2Re]$$

Vertical difference after correction:

$$H= S * [\sin\alpha + \cos\alpha * S * \cos\alpha (1-K) / 2Re]$$

If you do not correct the atmospheric refraction error and earth curvature, the formula for HD and VD:

- $D = S \cdot \cos\alpha$
- $H = S \cdot \sin\alpha$

In the formula:

- $K = 0.14$ - coefficient of atmospheric refraction
- $Re = 6370$ km - radius of earth curvature
- α (or β) - vertical angle measured from horizontal plane (vertical angle)
- S - slide distance



The default value of the atmospheric refraction is set to $K = 0.14$. K can be set to 0.14 or 0.2. It can also be closed. To modify the K value, refer to section 13 “Parameters”.

5.8. Setting minimum reading of setting angle/distance

Setting of minimum reading, the units of angle/distance measurement are selectable.

Angle unit : 1"/ 5"/ 10"/ 0.1"

Distance Unit: 1 mm/ 0.1 mm

[E.g.] Minimum Reading: 0.1"

- 1) Press [MENU] to enter to 1/2 of main menu, and press [5] (PARAMETERS).

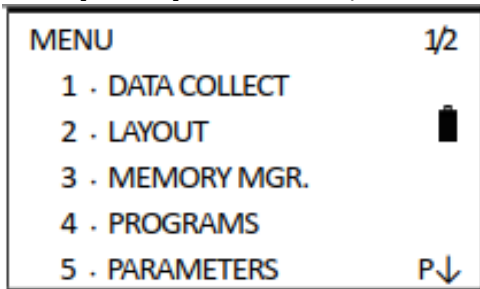

- 2) Press [3] (OTHER SET).

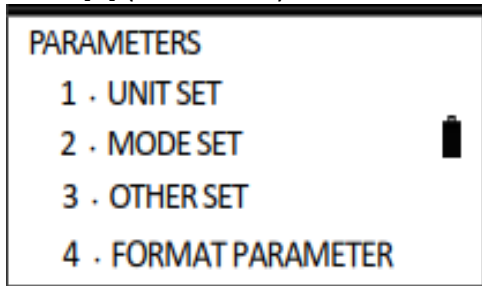

- 3) Press [1] (Min Angle Read).

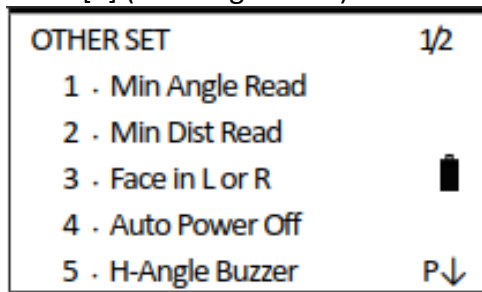

- 4) Press [1]~[4] to set the minimum angle reading. e.g.: Press [4] (0.1 second) and press [F4] (OK).

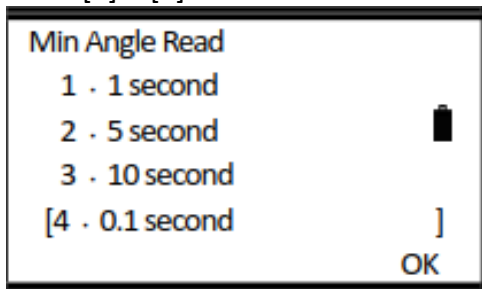

- 5) Return to menu of OTHER SET.

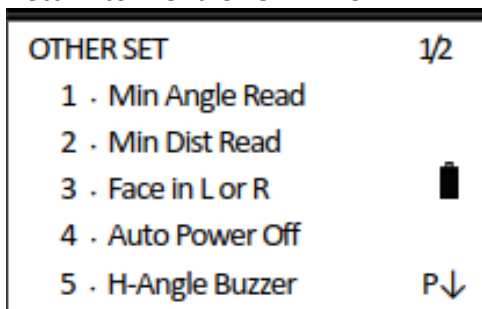

5.9. Setting auto power OFF

When no key is pressed, or no survey is implemented in 30 minutes, the instrument will be switched off automatically.

- 1) Press [MENU] to enter to 1/2 of the main menu, and press [5] (PARAMETERS).

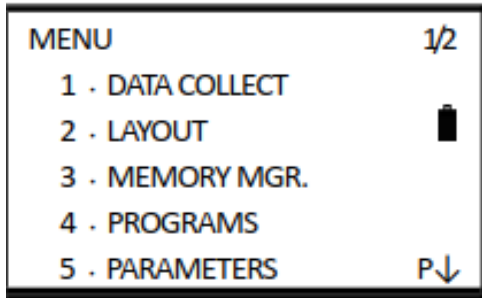

- 2) Press [3] (OTHER SET).

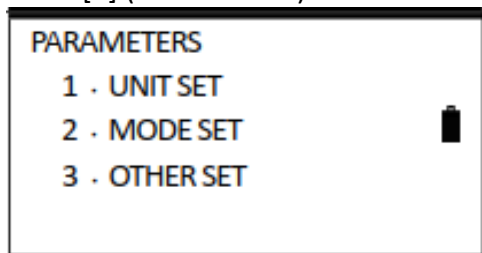

- 3) Press [4] (Auto Power Off).

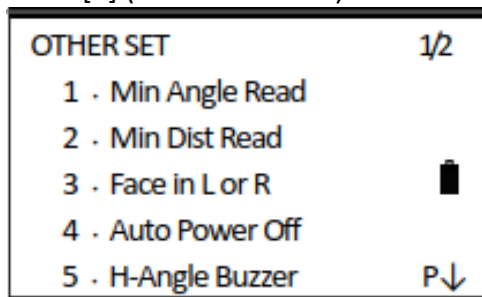

- 4) Press [1] (OFF) or [2] (ON), and press [F4] (OK).

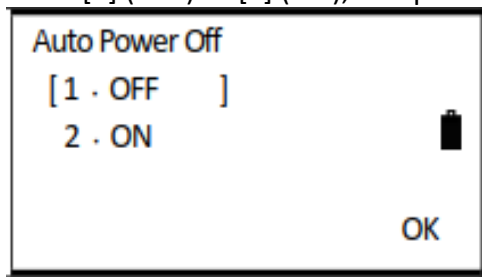

- 5) Return to menu of OTHER SET.

5.10. Setting instrument constant

Follow the method described in section 15.9 “Instrument constant (K)” to calculate the additive constant of the instrument. Setting of instrument constant is stated below.

- 1) Press [MENU] to enter to the main menu, and press [F4] (P↓) to turn to 2/2, then press [2].

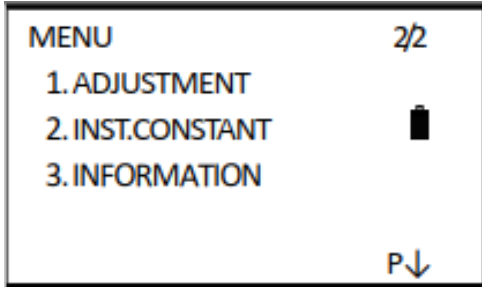

- 2) It displays the instrument constants and multiplication constant. Input the instrument constant and press [F4] (ENT).

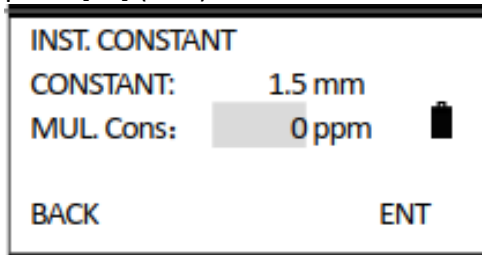

- 3) Return to 2/2 of the menu.2/2.

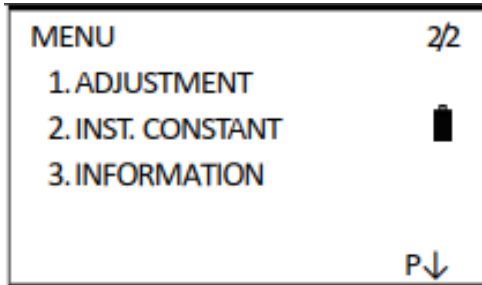

- 4) Press [ESC] to cancel the settings.



Refer to 6.7 “Method of inputting, alphanumeric characters” to learn how to input numbers or characters.



The instrument constant is strictly preset before release. Users are not recommended to modify such settings in normal use, unless user has implemented a precise measure (e.g. measurement made by professional inspection organization in a standard baseline field) and needs to modify the default settings.

5.11. Select a code file

- 1) Press [MENU] to enter to the main menu, press [3] into MEMORY MGR, press [4] into SELECT CODE FILE.

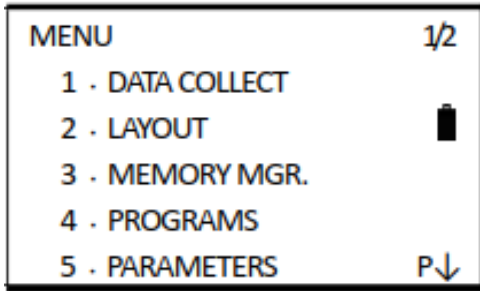

- 2) When it displays the interface of selecting a code file, enter the file name of the code you want to call up.

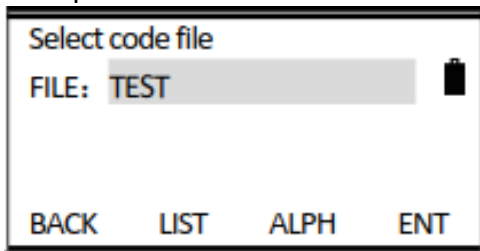

Refer to 6.7 “Method of inputting, alphanumeric characters” to learn how to input numbers or characters.

- 3) You can also press [F2] (LIST) to display the list in the memory. Press [F4] (OK) or [ENT] to enter to it and display the code list.

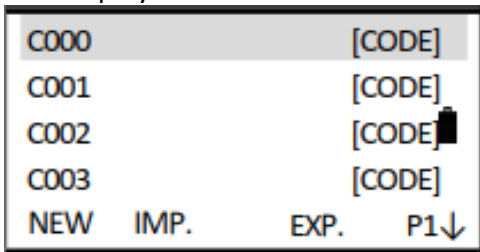

Refer to section 14 “Memory management” to know more about the instruction of disk list and operation.

- 4) Press [▲] or [▼] to move up or down to select a code file. Press [F4] to turn the page.

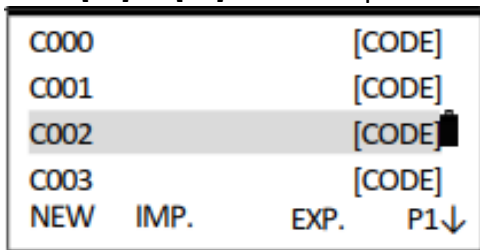

- 5) Press [ENT] (ENT). Succeed to call up a file. Back to MENU interface.

6. Preparation for measurements

6.1. Unpacking and storage of instrument

Unpacking of instrument

Place the case lightly with the cover upward, and unlock the case, take out the instrument.

Storage of instrument

Cover the telescope cap, place the instrument into the case with the vertical clamp screw and circular vial upwards (Objective lens towards tribrach), and slightly tighten the vertical clamp screw and lock the case.

6.2. Instrument setup

Mount the instrument to the tripod. Level and center the instrument precisely to ensure the best performance.

6.2.1. Leveling and Centering the Instrument by plumb bob

- 1) Set up the tripod.
- 2) First, extend the extension legs to suitable length, make the tripod head parallel to the ground and tighten the screws.
- 3) Make the center of the tripod and the occupied point approximately on the same plumb line.
- 4) Step on the tripod to make sure if it is well stationed on the ground.
- 5) Attaching the instrument on the tripod.
- 6) Place the instrument carefully on the tripod head and slide the instrument by loosening the tripod screw. If the plumb bob is positioned right over the center of the point, slightly tighten the tripod.
- 7) Roughly leveling the instrument by using the circular vial.
- 8) Turn the leveling screw A and B to move the bubble in the circular vial, in which case the bubble is located on a line perpendicular to a line running through the centers of the two leveling screw being adjusted .

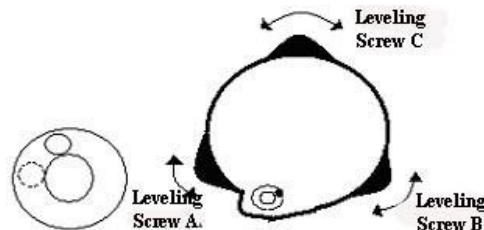

- 9) Turn the leveling screw C to move the bubble to the center of the circular vial.

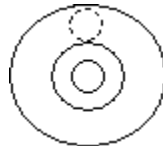

- 10) Precisely leveling by using the plate vial.

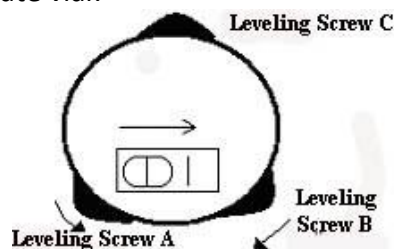

- 11) Rotate the instrument horizontally by loosening the horizontal clamp screw and place the plate vial parallel to the line connecting leveling screw A and B, and then bring the bubble to the center of the plate vial by turning the leveling screws A and B.
- 12) Rotate the instrument 90°(100g) around its vertical axis and turn the remaining leveling screw or leveling C to center the bubble once more.

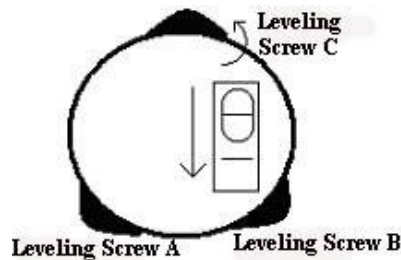

- 13) Repeat the steps 1 and 2 for each 90° (100 gon) rotation of the instrument and check whether the bubble is correctly centered in all directions.

6.2.2. Centering by using the laser plummet

- 1) Set up the tripod.
- 2) Lift tripod to suitable height, ensure equal length of three legs, spread and make tripod head parallel to the ground, and place it right above the measurement station point. Prop up tripod on the ground and fix one leg.
- 3) Install instrument and collimate the point
- 4) Set instrument carefully on tripod, tighten the central connecting screw. Hold the other two unfixed legs with both hands and adjust position of these two legs through observation of laser plummet. As it approximately aims at the station point, make all three legs fixed on the ground. Adjust three leg screws of the instrument to make laser plummet collimate precisely to the station point.
- 5) Use circular vial to roughly level the instrument.
- 6) Adjust length of three legs of tripod; make the circular vial bubble of the instrument in the middle.
- 7) Use plate vial to level the instrument accurately.
- 8) Rotate the instrument horizontally by loosening the Horizontal Clamp Screw and place the plate vial parallel to the line connecting leveling screw A and B, and then bring the bubble to the center of the plate vial by turning the leveling screws A and B.
- 9) Rotate the instrument 90°C, make it perpendicular to the connecting line of level screws A and B. Turn level screw C to make the bubble of the plate vial in the middle.
- 10) Precisely centering and leveling.
- 11) Through observation of laser plummet, slightly loosen the central connecting screw and move the instrument evenly (Don't rotate the instrument), making the instrument precisely collimating to the station point. Then tighten the central connecting screw and level the instrument precisely again.
- 12) Repeat this operation till the instrument collimate precisely to the measurement station point.

6.3. Loading, unloading, charging the battery and its information

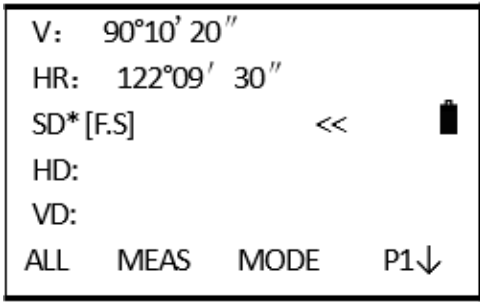

Symbol	Description
	Battery is full, good for operation)
	When displaying this status, the battery can be used for an hour; if you are not sure the time it has used, please prepare a substitutional battery or charge the battery
	The battery is low. Please abort the job and change or charge the battery
	Twinkles and disappears. It will just take several minutes when the symbol twinkles and finally disappears. The battery is empty and please change and charge the battery

Notice:

- The battery operating time will vary depending on the environmental conditions such as ambient temperature, charging time, the number of times of charging and discharging etc. It is recommended for safety to charge the battery beforehand or to prepare spare full charged batteries.
- The battery power remaining display shows the power level regarding the current measurement mode. The distance measurement mode consumes more power than angle measurement mode, so the power enough for the latter is not sure applicable for the previous one. Pay attention to this when switching angle measurement mode to distance measurement mode, because insufficient battery power might lead to interrupted operation.

Cautions for unloading the battery:

When unloading the battery, please switch off the instrument in case the instrument may be damaged.

Charging the battery

Charge the battery with the appropriate charger (LC-01). Before charging, link the charger with the electrical outlet first. Unload the battery from the instrument and connect the charger plug with the charging outlet of the battery. When the indicator light of the charger is red, it means the battery is being charged. When the light is green, it means the battery is charged and full, please pull out the plug.

Cautions for charging

- The charger has built-in circuitry for protection from overcharging. However, do not leave the charger plugged into the power outlet after recharging is completed.
- Be sure to recharge the battery at a temperature of 0°~±45°C, recharging may be abnormal beyond the specified temperature range .

- When the indicator lamp does not light after connecting the battery and charger, either the battery or the charger may be damaged. Please connect professionals for repairing.

Cautions for storage:

- Rechargeable battery can be repeatedly recharged 300 to 500 times. Complete discharge of the battery may shorten its service life.
- To get the maximum battery life, be sure to recharge it at least once a month.

6.4. Reflecting prism

When measuring distance, a reflector prism needs to be placed at the target place. Reflector systems come with single prism and triple prisms, which can be mounted with tribrach onto a tripod or mounted onto a prism pole. Reflector systems can be self-configured by users according to job.



6.5. Mounting and dismounting instrument from tribrach

Dismounting

If necessary, the instrument (including reflector prisms with the same tribrach) can be dismounted from tribrach. Loosen the tribrach locking screw in the locking knob with a screwdriver. Turn the locking knob about 180° counter-clockwise to disengage anchor jaws and take off the instrument from tribrach.

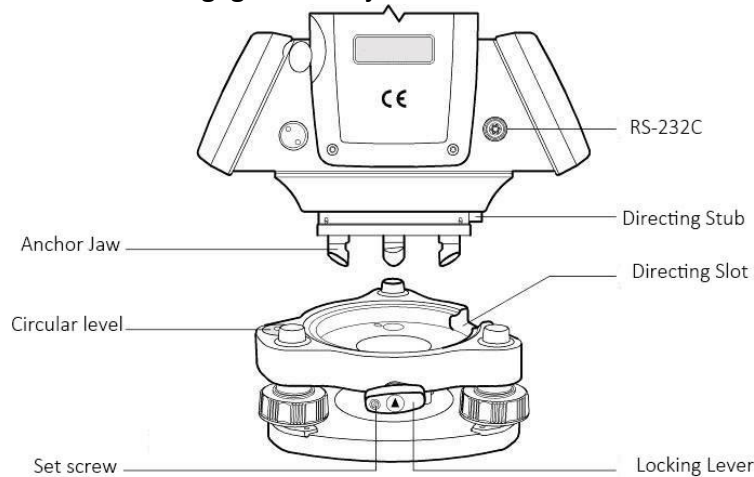

Mounting

Insert three anchor jaws into holes in tribrach and line up the directing stub with the directing slot. Turn the locking knob about 180° clockwise and tighten the locking screw with a screwdriver.

6.6. Eyepiece adjustment and collimating object

Method of collimating object (for reference)

- 1) Sight the telescope to bright place and rotate the eyepiece tube to make the reticle clear.
- 2) Collimate the target point with top of the triangle mark in the coarse collimator. (Keep a certain distance between eye and the coarse collimator).
- 3) Make the target image clear with the telescope focusing screw.



If there is parallax when your eye moves up, down or left, right, it means the diopter of eyepiece lens or focus is not well adjusted and accuracy will be influenced, so you should adjust the eyepiece tube carefully to eliminate the parallax.

6.7. Method of inputting, alphanumeric characters

Total station CTS-112R series is equipped with alphanumeric keyboards. User can input number and characters during operation.

Inputting numbers

Example1: input the instrument height in data collect mode.

- 1) The arrowhead points to the item which needs to be input. Press [▲] [▼] to move up or down the arrowhead.

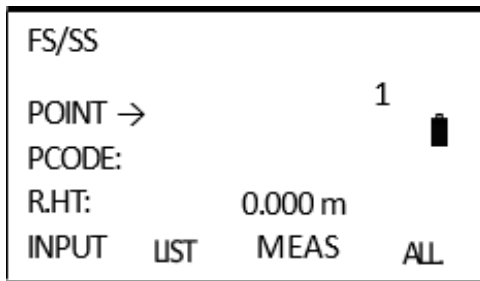

- 2) Press [▼] to move the “→” to the item of “R.HT”.
- 3) Press [F1] (INPUT) to activate the inputting function. The item of reflector height will appear a cursor.

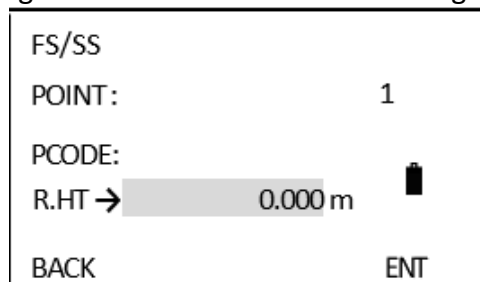
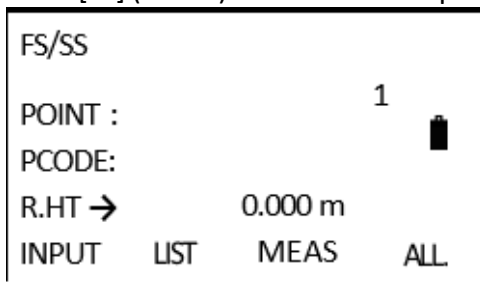

- 4) Press [1] to input a “1”.
- 5) Press [.] to input a “.”.
- 6) Press [5] to input a “5”.
- 7) After inputting, press [F4] to confirm.

Then the instrument height is defined to 1.5 m.

Inputting angle

Example2: input the angle 90°10'20".

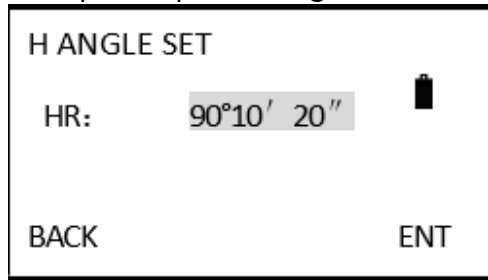

The screenshot shows a calculator screen with the text "H ANGLE SET" at the top. Below it, "HR:" is followed by a highlighted input field containing "90°10' 20" and a battery icon. At the bottom left is the "BACK" button and at the bottom right is the "ENT" button.

- 1) Press [9] to input a "9"; press [0] to input a "0". Press [.] to input the unit "°".
- 2) Press [1] to input a "1"; press [0] to input a "0". Press ['] to input the unit "'".
- 3) Press [2] to input a "2"; press [0] to input a "0". Press [F4] to confirm.

Then the horizontal angle is defined as 90°10'20".



When "ALPH" shows, it means you can type numbers, while "NUM" shows, it means you can type characters.

Press [F1] (BACK) to delete the characters or numbers you entered.

7. Angles measurements

7.1. Measuring horizontal and vertical angles

Go to angle measurement mode.



- 1) Procedure: aim the first target A.

Operation: collimate A

V :	82°09' 30"	
HR :	90°09' 30"	
ALL	OSET	HSET P1↓

- 2) Procedure: press [F2] (OSET) and [F4] (YES) to define the horizontal angle of target A to 0°00'00".

Operation: [F2] [F4]

H ANGLE O SET?		
[NO]	[YES]	
V :	82°09' 30"	
HR:	0°00' 00"	
ALL	OSET	HSET P1↓

- 3) Procedure: aim the second target B, it displays the V/H of target B.

Operation: collimate B

V :	92°09' 30"	
HR:	67°09' 30"	
ALL	OSET	HSET P1↓

Method to shoot the target (for reference)

- 1) Sight the telescope to the bright sky. Turn the focusing ring until you can see the cross hair clearly.
- 2) Aim the target by observing through the tip of the triangle on the telescope. Keep some distance between your eyes and the eyepiece.
- 3) Rotate the telescope focusing nob until the object can be seen clearly.



If there are deviations when moving your eye up, down, left or right, it proves that the focus or the diopter of the eyepiece is not adjusted well, which will affect the observation accuracy. You should focus and adjust the eyepiece sleeve carefully to eliminate such errors.

7.2. Shift the horizontal angle (right/left)

Go to angle measurement mode.

- 1) Procedure: press [F4] (↓) twice to turn to P3.

Operation: [F4] x 2

V :	122°09' 30"		
HR:	90°09' 30"		
ALL	OSET	HSET	P1↓
HOLD	REP.	V%	P2↓
H-BZ	R/L	CMPS	P3↓

- 2) Procedure: press [F2] (R/L) to shift the mode from horizontal right angle (HR) to left angle (HL).

Operation: [F2]

V :	122°09' 30"		
HL:	269°50' 30"		
H-BZ	R/L	CMPS	P3↓

- 3) Procedure: press [F2] again to return to the mode of horizontal right angle (HR).



Every pressing on [F2] (R/L) is to shift between HR/HL.

7.3. Setting horizontal angle

7.3.1. Setting by [HOLD]

Go to angle measurement mode.

- 1) Procedure: rotate telescope to the horizontal angle which is to be defined by horizontal tangent screw.

Operation: display the angle

V :	122°09' 30"		
HR:	90°09' 30"		
ALL	OSET	HZET	P1↓

- 2) Procedure: press [F4] to turn to P2.

Operation: [F4]

V :	122°09' 30"		
HR:	90°09' 30"		
HOLD	REP.	V%	P2↓

-
- 3) Procedure: press [F1] (HOLD).
Operation: [F1]

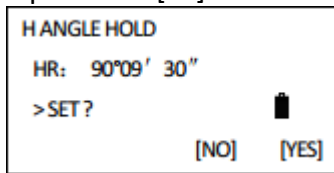

- 4) Procedure: aim to the target point.
Operation: aim the target

- 5) Procedure: press [F4] (YES) to hold the horizontal angle. Return to angle measurement mode as shown on the right.

Operation: [F4]

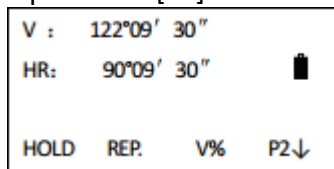

To return to last mode, press [F3] (NO).

7.3.2. Setting by Inputting through the Keyboard

Go to angle measurement mode.

- 1) Procedure: aim to the target point and press [F3] (HSET).
Operation: collimate [F3]

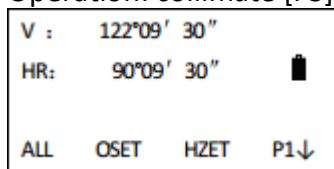

- 2) Procedure: input the desired horizontal angle by the keyboard and press [F4] (ENT), e.g. 150°10'20\"/>
Operation: [F4]

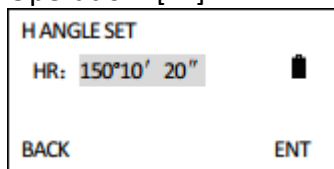

- 3) Procedure: Hz angle is defined.

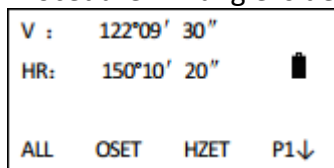

Refer to 6.7 “Method of inputting, alphanumeric characters” to learn how to input numbers or characters. Input the angle units “°”, “’” and “”” by press [.]

7.4. Shift between V angle and V%

Go to angle measurement mode.

- 1) Procedure: press [F4] (↓) to turn to P2.

Operation: [F4]

V :	90° 10' 20"		
HR:	120° 09' 30"		
ALL	OSET	HZET	P1↓
OSET	REP.	V%	P2↓

- 2) Procedure: press [F3] (V %).

Operation: [F3]

V :	10.30%		
HR:	120° 09' 30"		
HOLD	REP.	V%	P2↓



Press [F3] (V%) to shift the mode displaying.

When the height exceeds 45° (100%), it will show "<Over>" (beyond the survey range)

- 3) Procedure: press [F4] (↓) to turn to P2.

Operation: [F4]

V :	90° 10' 20"		
HR:	120° 09' 30"		
ALL	OSET	HZET	P1↓
OSET	REP.	V%	P2↓

- 4) Procedure: press [F3] (V %).

Operation: [F3]

V :	10.30%		
HR:	120° 09' 30"		
HOLD	REP.	V%	P2↓



Press [F3] (V%) to shift the mode displaying.

When the height exceeds 45° (100%), it will show "<Over>" (beyond the survey range)

7.5. Repetitious angle measurement

Under horizontal angle (HR) measurement mode, user can implement repetitious angle measurement. Make sure it is under horizontal angle (HR) measurement mode.

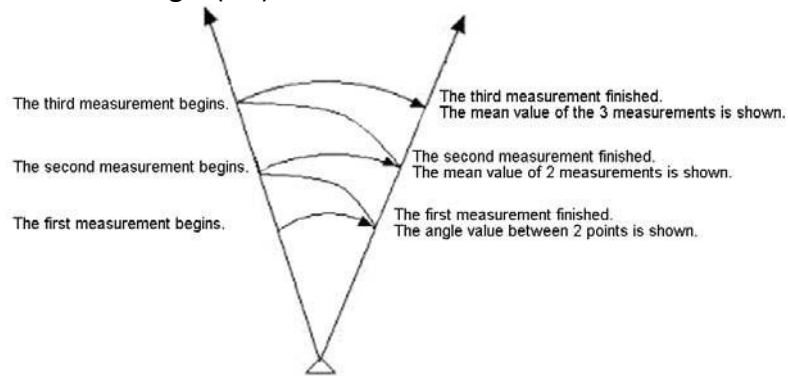

- 1) Procedure: press [F4] (↓) to turn to P2.

Operation: [F4]

V:	90°10' 20"		
HR:	120°09' 30"		
ALL	OSET	HSET	P1↓
HOLD	REP.	V%	P2↓

- 2) Procedure: press [F2] (REP).

Operation: [F2]

Rep-Angle Count	[0]
Ht:	90°10' 20"
Hm:	
HR :	90°09' 30"
OSET	EXIT HOLD

- 3) Procedure: aim to target A and press [F1] (OSET).

Operation: collimate A [F1]

Repetition Angle	
OSET?	
[NO]	[YES]

- 4) Procedure: press [F4] (YES).

Operation: [F4]

Rep-Angle Count	[0]
Ht:	0°00' 00"
Hm:	
HR :	0°00' 00"
OSET	EXIT HOLD

- 5) Procedure: aim to target B by rotating the horizontal clamp and tangent screws, and press [F4] (HOLD).

Operation: collimate B [F4]

Rep-Angle Count	[1]
Ht: 120°20' 00"	
Hm: 120°20' 00"	
HR : 120°20' 00"	
OSET EXIT REL	

- 6) Procedure: aim A again by adjusting horizontal clamp and tangent screws and press F3] (REL).

Operation: collimate A [F3]

Rep-Angle Count	[1]
Ht: 120°20' 00"	
Hm: 120°20' 00"	
HR : 120°09' 30"	
OSET EXIT HOLD	

- 7) Procedure: aim B again and press [F4] (HOLD).

Operation: collimate B [F4]



Rep-Angle Count	[2]
Ht: 240°40' 00"	
Hm: 120°20' 00"	
HR : 120°18' 00"	
OSET EXIT REL	

- 8) Procedure: Repeat procedure 6 and 7 until desired times of measurement are finished. E.g. repeat 6 times.

Rep-Angle Count	[6]
Ht: 722°00' 00"	
Hm: 120°20' 00"	
HR : 120°20' 00"	
OSET EXIT REL HOLD	

- 9) Procedure: to quit the repetitious angle measurement, press [F2] (EXIT) and press [F4] (YES) to return to normal angle measurement mode.

Operation: [F2] [F4]

Repetition Angle	
Exit ?	
[NO]	[YES]
<hr/>	
V : 90°10' 20"	
HR: 120°09' 30"	
HOLD	REP. V% P2↓



Horizontal angle can be totaled from 3600°00'00" to minimum reading. Under horizontal right angle: E.g.: when minimum reading is 5", horizontal angle can be totaled to ±3599°59'55".

When the difference between the measured angle result and the first result exceed ±30", then an error message will show.

7.6. Shift between azimuth and vertical angle

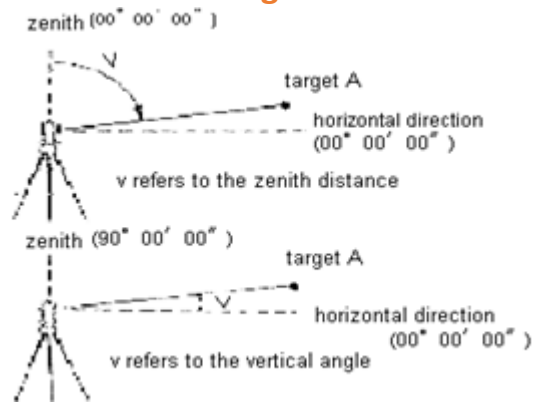

- 1) Procedure: press [F4] (↓) twice to turn to P3.

Operation: [F4] x 2

V :	19°51' 27"		
HR:	170°30' 20"		🔋
ALL	OSET	HSET	P1↓
CMPS	R/L	FILE	P3↓

- 2) Procedure: Press [F1] (CMPS).

Operation: [F3]

V :	70°08' 33"		
HR:	170°30' 20"		🔋
CMPS	R/L	FILE	P3↓



Every pressing [F1] (CMPS) can shift these 2 modes.

8. Distance measurements

User should avoid measuring distance to targets with high reflectivity (e.g. traffic light) neither in IR distance measurement mode or in laser reflectorless distance mode, otherwise the measured distance is incorrect or inaccurate.

When pressing [MEAS], the total station will measure the distance from the instrument to the target. During distance measurement, if laser will pass cars, animals or shaking branches block the light path, some light beams maybe reflected to the instrument, which will lead a wrong result of measurement. Under the mode of reflectorless and reflecting sheet, user should avoid the light path being blocked by other objects.

Reflectorless distance measurements

- Make sure the laser beam is not reflected by any reflecting objects nearby.
- When starting distance measurement, EDM will measure the distance to the target on the light path. If there're passing objects (like cars, rain, snow or frog), EDM will measure the distance to the nearest object.
- When measuring a longer distance, the laser beam may deviate from the line of sight, which will affect the accuracy. This is because the emitting point of laser beam may not coincide the point which is collimated by the crosshair. Thus, users are recommended to adjust the instrument precisely to ensure the laser beam is consistent with the collimation line (refer to section 15.11 "Reflectorless EDM").
- Do not measure the same target with 2 instruments.

To implement precise distance measurement to the prism, user should adopt standard mode (Prism mode).

Laser distance measurement with reflecting sheet

Reflecting sheet can be also used in laser distance measurement. To ensure a high accuracy, please make sure the laser beam is perpendicular to the reflecting sheet, coupled with precise adjustment (refer to section 15.11 "Reflectorless EDM").

Ensure the right additive constant of different prisms

Before measure the distance, atmospheric correction and prism constant are needed to be set. Please refer to section 5 "Description of the instrument" know more about how to set atmospheric correction and prism constant.

8.1. Distance measurements

- 1) Procedure: press [DIST] to enter to interface of distance measurement. Start distance survey.
Operation: [DIST]

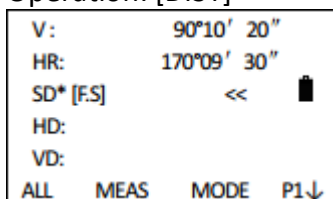

Under electronic distance measurement (EDM), the symbol "*" will show on the screen.

2) Procedure: it displays the measured distances.

```
V:      90°10' 20"
HR:     170°09' 30"
SD*     241.551m
HD:     235.343m
VD:     36.551m
ALL  MEAS  MODE  P1↓
```



Units of distance: "m" (meter), "ft" (feet), "fi" (feet inch).

If the measurement result is affected by atmospheric agitation, the instrument will repeat the survey operation automatically.

3) Procedure: press [F1] (ALL) to start measurement and record the data. After measurement, press [F4] (YES) to return to distance measurement mode. After the measurement of one point is finished, the name of next point will be automatically +1. Repeat the procedure above to start new measurement.

Operation: [F1] [F4]

```
V:      90°10' 20"
HR:     170°09' 30"
SD*     241.551m
HD:     235.343m
VD:     36.551m
> REC.? [NO] [YES]

POINT: 1
PCODE: SOUTH
V : 90°10' 20"
HR: 170°09' 30"
SD: 241.551m
< Complete >
```



Refer to section 10 "Data collection".

8.2. Setting measurement mode

Total station CTS-112R series provide measurement modes as following: Fine.S/F.3/F.R/T.R. Under F.3 mode, the instrument will measure 3 times and calculate the average value.

1) Procedure: press [DIST] to enter to distance measurement interface. Start distance measurement.

Operation: [DIST]

```
V:      90°10' 20"
HR:     170°09' 30"
SD* [F.S] <<
HD:
VD:
ALL  MEAS  MODE  P1↓
```

- 2) Procedure: press [F3] (MODE) to shift measurement modes among F.S/F.3/F.R/T.R.

Operation: [F3]

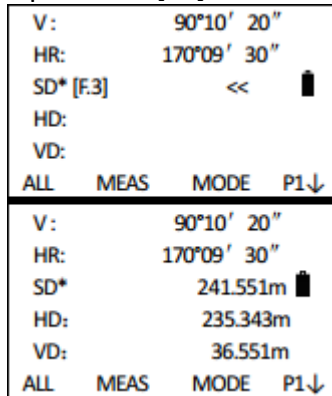

8.3. Stakeout

This function can display the difference between the distance measured and the distance of stakeout. During stake-out, user can choose any mode (HD, VD and SD) to stake out.

- 1) Procedure: press [F4] under distance measurement mode to enter to P2.

Operation: [F4]

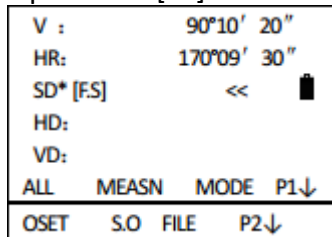

- 2) Procedure: press [F2] (S.O) to display the data of previous settings.

Operation: [F2]

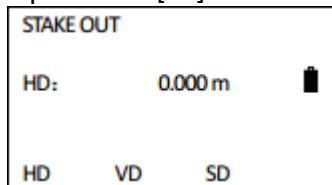

- 3) Procedure: press [F1]-[F3] to select the stake out mode. F1:HD, F2:VD, F3:SD. E.g.: press [F1] (HD) to adopt horizontal distance stake out.

Operation: [F1]

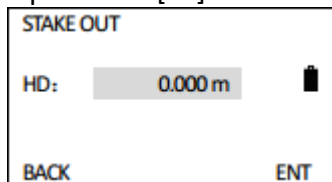

- 4) Procedure: input distance to stake out (e.g. 3.500 m) After inputting, press [F4] (ENT).

Operation: input 3.500 [F3]

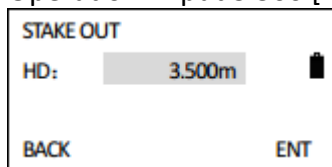



Press [F1] (NEXT) to return to Procedure4.

5) Procedure: aim to the target (prism) and start to measure. It displays the difference between the distance measured and the distance to stake out

Operation: aim to prism

V :	99°46' 02"		
HR:	160°52' 06"		
SD:	2.164 m		🔋
dHD:	-1.367 m		
VD:	-0.367 m		
OFSET	S.O	FILE	P2↓

6) Procedure: move the prism until the difference close to 10.

V :	99°46' 02"		
HR:	160°52' 06"		
SD:	2.164 m		🔋
dHD:	0.000 m		
VD:	-0.367 m		
OFSET	S.O	FILE	P2↓

8.4. Offset measurement

There are 4 offset measurement modes:

- Angle offset measurement
- Distance offset measurement
- Plane offset measurement
- Column offset measurement

8.4.1. Angle offset

If it is difficult to set up a prism directly, for example the center of a tree, this mode is helpful. It only needs to set the prism on the point which has the same horizontal distance to the instrument as that of the prism to the instrument. Then define the instrument height/target height to start offset measurement, you can get the coordinates of the center of the object.

When measuring the coordinates of A1 which is the projection of A0, set the instrument height/target height. Only measure the coordinates of A0: only define the instrument height (set target height as 0). Before the offset measurement, define the instrument height/target height first. Refer to section 9.2 "Setting coordinates of occupied point".

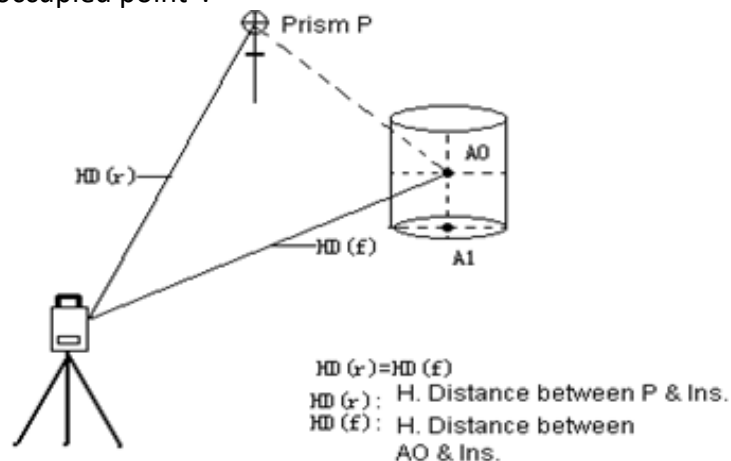

1) Procedure: press [F4] (P1↓) under distance measurement mode to enter to P2.

Operation: [F4]

V :	99°46' 01"		
HR:	161°00' 52"		
SD*	2.207 m		
HD:	-1.326 m		
VD:	-0.374 m		
ALL	MEAS	MODE	P1↓
OFSET	S.O	FILE	P2↓

2) Procedure: press [F1] (OFSET).

Operation: [F1]

Offset
1. ANG. OFFSET
2. DIST. OFFSET
3. PLANE OFFSET
4. COLUMN OFFSET

3) Procedure: press [1] (ANG. OFFSET) to enter to angle offset measurement mode.

Operation: [1]

ANG. OFFSET	
HR:	170°01' 15"
SD:	
HD:	
VD:	
MEAS	

4) Procedure: aim to prism (P) and press [F1] (MEAS). It measures the distance between the instrument and the prism.

Operation: collimate P

ANG. OFFSET	
HR:	170°01' 58"
SD* [T.R]	<
HD:	
VD:	
Measuring.....	
ANG. OFFSET	
HR:	170°01' 55"
SD*	2.207 m
HD:	2.175 m
VD:	-0.374 m
NEXT	

5) Procedure: aim to A0 by horizontal clamp and tangent screws. It displays the SD, HD, and VD from the instrument to A0.

Operation: collimate A0

ANG. OFFSET	
HR:	160°01' 55"
SD*	2.557 m
HD:	2.175 m
VD:	1.278 m
NEXT	

6) Procedure: to display the coordinates of AO or A1 press [CORD].

Operation: [CORD]

ANG. OFFSET	
HR:	157°04' 300"
N :	34.004 m
E :	47.968 m
Z :	24.146 m
NEXT	



Press [ESC] to return to distance measurement mode.

8.4.2. Distance offset

If the radius of the tree or lake is known, now to measure the distance and coordinates of the center, you need to input the oHD (offset distance) as the following graph and measure P1 under the mode of distance offset. the distance and coordinates of P0 will be displayed in the screen.

Refer to section 9.2 "Setting coordinates of occupied point".

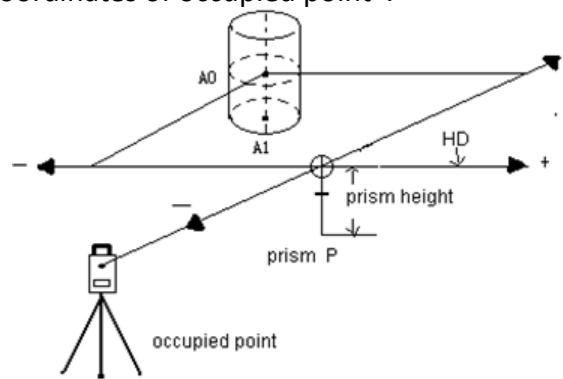

1) Procedure: press [F4] under distance measurement mode to enter to P2.

Operation: [F4]

V :	99°46' 01"		
HR:	157°01' 10"		
SD*	2.207 m		
HD:	-1.326 m		
VD:	-0.374 m		
ALL	MEAS	MODE	P1↓
OFSET	S.O	FILE	P2↓

2) Procedure: press [F1] (OFSET).

Operation: [F1]

Offset	
1.	ANG. OFFSET
2.	DIST. OFFSET
3.	PLANE OFFSET
4.	COLUMN OFFSET

3) Procedure: press [2] (DIST. OFFSET) to enter to offset measurement.

Operation: [2]

```
DIST. OFFSET
INPUT L or R oHD
: 0.000 m
INPUT FORWARD oHD
: 0.000 m
BACK ENT
```

4) Procedure: input offset distance of left or right, and forward. Then press [F4] (ENT).

Operation: input L/R, forward offset distance

```
DIST. OFFSET
INPUT L or R oHD
: 1.600 m
INPUT FORWARD oHD
: 2.000 m
BACK ENT
```

5) Procedure: aim to P1 and press [F1] (MEAS) to start measurement. When distance measurement is finished, it displays the measured result that is corrected by offset distance.

Operation: collimate P1 [F1]

```
DIST. OFFSET
HR: 157°15' 12"
SD*
HD:
VD:
MEAS

DIST. OFFSET
HR: 173°17' 25"
SD: 4.698 m
HD: 4.691 m
VD: 0.249 m
NEXT
```

6) Procedure: press [CORD] to display the coordinates of PO.

Operation: [CORD]

```
DIST. OFFSET
HR: 173°17' 25"
N : 31.314 m
E : 47.508 m
Z : 23.626 m
NEXT
```



Press [F1] (NEXT) to return to Procedure 4.

Press [ESC] to return to distance measurement mode.

8.4.3. Plane offset

This function can measure the point that cannot be measured directly, e.g. measure the distance or coordinates of a plane edge.

First, measure any 3 points of the plane (P1, P2, P3) in this mode. Then aim to P0. It will calculate and display the distance and coordinates of the intersection of collimation line and this plane.

Refer to section 9.2 "Setting coordinates of occupied point".

P1, P2, P3 are three random prism points.

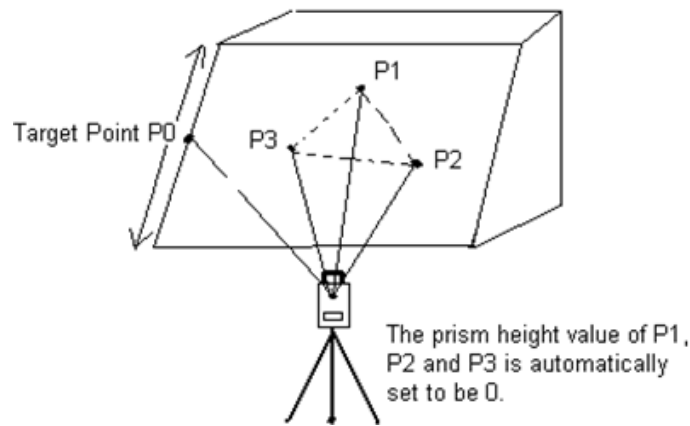

- 1) Procedure: press [F4] (P1↓) under distance measurement mode to enter to P2.

Operation: [F4]

V :	94°16' 23"	
HR:	143°46' 52"	
SD*	2.438 m	🔋
HD:	2.429 m	
VD:	-0.214 m	
ALL	MEAS	MODE P1↓
OFFSET	S.O	FILE P2↓

- 2) Procedure: press [F1] (OFFSET).

Operation: [F1]

Offset
1. ANG. OFFSET
2. DIST. OFFSET
3. PLANE OFFSET
4. COLUMN OFFSET

- 3) Procedure: press [3] (PLANE OFFSET).

Operation: [3]

PLANE OFFSET
No. 01
HR: 153°49' 46"
SD:
HD:
MEAS

-
- 4) Procedure: aim to the prism (P1) and press [F1] (MEAS). After measurement it will forward to the measurement of the second point.

Operation: collimate P1 [F1]

```
PLANE OFFSET
No.01
HR:      151°49' 46"
SD: [T,R]  <
HD:
Measuring.....
```

- 5) Procedure: measure the second and third point with the same method.

Operation: aim to P2 and press [F1]; aim to P3 and press [F1]

```
PLANE OFFSET
No.02
HR: 155°24' 05"
SD: [T,R]  <
HD:
Measuring.....

PLANE OFFSET
No.03
HR: 148°28' 58"
SD: [T,R]  <
HD:
Measuring.....
```

- 6) Procedure: it will calculate and display the distance and coordinates of the intersection of collimation line and this plane.

Operation: [2]

```
PLANE OFFSET
HR:      148°28' 58"
SD:      2.479 m
HD:      2.472 m
VD:      0.685 m
NEXT
```

- 7) Procedure: aim to the edge of the plane (P0).

Operation: collimate P0

```
PLANE OFFSET
HR:      157°57' 29"
SD:      3.068 m
HD:      3.059 m
VD:      0.703 m
NEXT
```

8) Procedure: press [CORD] to display the coordinates of P0.

Operation: [CORD]

PLANE OFFSET	
HR:	157°57' 29"
N :	33.644 m
E :	47.968 m
Z :	26.299 m
NEXT	



Press [F1] (NEXT) to return to Procedure4.

Press [ESC] to return to distance measurement mode.

8.4.4. Column offset

First, measure the distance to the point (P1) of the column surface directly. Then by measuring the azimuth angles of P2 and P3 on the column, you can calculate the distance, azimuth and coordinates of the column center. Azimuth of the column center is the average value of point of column surface (P2) and azimuth (P3).

Refer to section 9.2 "Setting coordinates of occupied point".

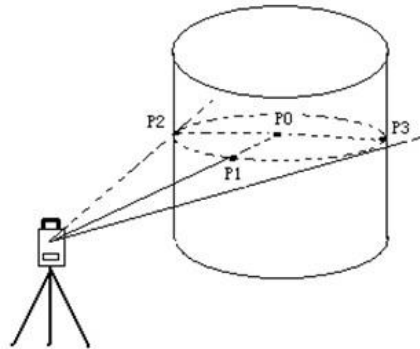

1) Procedure: press [F4] (P1↓) under distance measurement mode to enter to P2.

Operation: [F4]

V :	94°16' 23"		
HR:	143°46' 52"		
SD*	2.438 m		
HD:	2.429 m		
VD:	-0.214 m		
ALL	MEAS	MODE	P1↓
OFFSET	S.O	FILE	P2↓

2) Procedure: press [F1] (OFFSET).

Operation: [F1]

Offset	
1.	ANG. OFFSET
2.	DIST. OFFSET
3.	PLANE OFFSET
4.	COLUMN OFFSET

3) Procedure: press [4] (COLUMN OFFSET).

Operation: [4]

```
COLUMN OFFSET
Center
HR: 147°13' 57"
SD:
HD:
MEAS
```

4) Procedure: aim to the center of the column (P1) and press [F1] (MEAS) to start measuring. After measurement, the system will remind you to implement angle measurement of the left point(P2).

Operation: shoot P1 and press [F1]

```
COLUMN OFFSET
Center
HR: 147°13' 57"
SD: [T.R] <
HD:
>Measuring....
```

5) Procedure: aim to the left point of the column surface (P2) and [F4] (SET) to finish measurement. Then it will display the message to measure the angle of the right point (P3). When displaying "<Range Error>", it reminds you to focus on the right target.

Operation: collimate P2 and press [F4]

```
COLUMN OFFSET
LEFT
HR: 155°20' 03"
SD: 2.455 m
HD: 2.445 m
SET
```

6) Procedure: collimate the right of the column surface (P3) and press [F4] (SET). Then the distance between the instrument and the column center (P0) will be calculated.

Operation: collimate P3 and press [F4]

```
COLUMN OFFSET
RIGHT
HR: 122°08' 05"
SD: 2.455 m
HD: 2.445 m
SET

COLUMN OFFSET
HR: 113°43' 06"
SD: 0.219 m
HD: 2.863 m
VD: -0.219 m
NEXT
```

7) Procedure: to display the coordinates of P0, press [CORD].

Operation: [CORD]

COLUMN OFFSET	
HR:	113°43' 06"
N :	2.782 m 
E :	0.679 m
Z :	1.781 m
NEXT	



Press [F1] (NEXT) to return to Procedure4.

Press [ESC] to return to distance measurement mode.

9. Coordinates measurements

9.1. Procedure of coordinates measurements

When measuring the coordinates after inputting the instrument height and target height, you can measure the unknown coordinates directly.

- To define the coordinates of occupied point, refer to section 9.2 “Setting coordinates of occupied point”.
- To define the instrument height and target height, refer to 9.3 “Setting the instrument height” and 9.4 “Setting the target height”.
- To measure the coordinates, you should define the backsight point and measure the azimuth of backsight point first.

The coordinates of unknown point can be calculated by the formula below:

Coordinates of occupied point (N0, E0, Z0); the coordinates of the target corresponding to the center of the instrument (n, e, z); instrument height INS. HT; coordinates of unknown point (N1, E1, Z1); target height R. HT VD : Z(VD)

$$N1=N0+n \quad E1=E0+e \quad Z1=Z0+INS. HT+Z-R. HT$$

Coordinates of instrument center ((N0, E0, Z0+INS. HT)

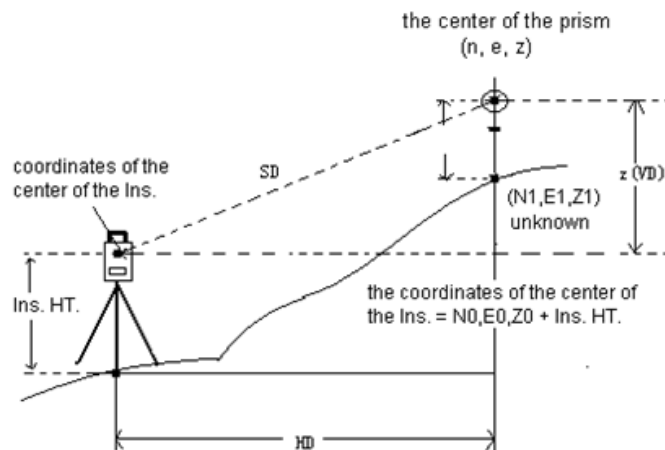

Caution during coordinates measurement: to define the coordinates of occupied point, instrument height, target height and backsight azimuth first.

1) Define the azimuth of known point A.

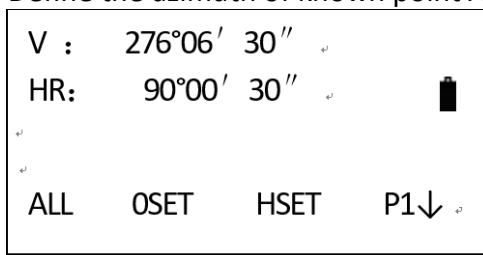

Inputting range: $-99999999.9999 \leq N, E, Z \leq +99999999.9999$ m

$-99999999.9999 \leq N, E, Z \leq +99999999.9999$ ft

$-99999999.11.7 \leq N, E, Z \leq +99999999.11.7$ ft+inch

2) Aim to target B and press [CORD].

```
V : 276°06' 30" ↵
HR: 90°09' 30" ↵
N *[F.S] < m 🔋 ↵
E : m ↵
Z : m ↵
ALL OSET HSET P1↓ ↵
```

3) Start measurement and press [F2] (ALL) to restart measurement.

```
V : 276°06' 30" ↵
HR: 90°09' 30" ↵
N : 36.001 m 🔋 ↵
E : 49.180 m ↵
Z : 23.834 m ↵
ALL OSET HSET P1↓ ↵
```

4) Press [F1] (ALL) to start coordinates measurement and record the result. After measurement, press [F4] (YES) to return to coordinates measurement. After measurement of one point, the system will add +1 to the point name. Repeat the procedures to restart a new measurement.

```
V : 276°06' 30" ↵
HR: 90°09' 30" ↵
N : 36.001 m 🔋 ↵
E : 49.180 m ↵
Z : 23.834 m ↵
> REC.? [NO] [YES] ↵
POINT: 1 ↵
PCODE: SOUTH ↵
N : 36.001 m 🔋 ↵
E : 49.180 m ↵
Z : 23.834 m ↵
< Complete > ↵
```

9.2. Setting coordinates of occupied point

By setting the coordinates of the instrument (occupied point) with respect to the origin of coordinates, the instrument can transform and display the coordinates of unknown point (target point) under this coordinates system.

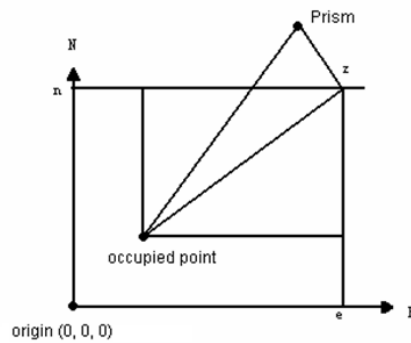

- 1) Under coordinates measurement mode, press [F4] (P1↓) to turn to P2.

V :	95°06' 30"	↵
HR:	86°01' 59"	↵
N :	0.168 m	↵
E :	2.430 m	↵
Z :	1.782 m	↵
ALL	MEAS	MODE P1↓ ↵
HT	BS	OCC. P2↓ ↵

- 2) Press [F3] (OCC.).

OCC.PT INPUT ↵		
NO	0.000	m ↵
EO:	0.000	m ↵
ZO:	0.000	m ↵
BACK		ENT ↵

- 3) Input coordinate N and press [F4].

OCC.PT INPUT ↵		
NO:	36.976	m ↵
EO:	0.000	m ↵
ZO:	0.000	m ↵
BACK		ENT ↵



Inputting range: $-99999999.9999 \leq N, E, Z \leq +99999999.9999$ m

$-99999999.9999 \leq N, E, Z \leq +99999999.9999$ ft

$-99999999.11.7 \leq N, E, Z \leq +99999999.11.7$ ft+inch

- 4) Input the coordinate E and Z with the same method. After inputting, return to coordinates measurement mode.

V :	95°06' 30"		
HR:	86°01' 59"		
N :	36.976 m		
E :	30.008 m		
Z :	47.112 m		
HT	BS	OCC.	P2↓

9.3. Setting the instrument height

Instrument height will be saved even the power is switched off.

- 1) Under coordinates measurement mode, press [F4] (P1↓) to turn to P2.

V :	95°06' 30"		
HR:	86°01' 59"		
N :	0.168 m		
E :	2.430 m		
Z :	1.782 m		
ALL	MEAS	MODE	P1↓
HT	BS	OCC.	P2↓

- 2) Press [F1] (HT) to display the instrument height and the target height.

HEIGHT INPUT		
INS.HT:	0.000 m	
R.HT :	0.000 m	
BACK		ENT

- 3) Input the instrument height and press [F4] (ENT).

HEIGHT INPUT		
INS.HT:	2.000 m	
R.HT :	0.000 m	
BACK		ENT



Inputting range: $-99999999.9999 \leq N, E, Z \leq +99999999.9999$ m

$-99999999.9999 \leq N, E, Z \leq +99999999.9999$ ft

$-99999999.11.7 \leq N, E, Z \leq +99999999.11.7$ ft+inch

9.4. Setting the target height

This function is used to acquire Z coordinates. Target height will be saved even the power is switched off.

- 1) Under coordinates measurement mode, press [F4] (P1↓) to turn to P2.

V :	95°06' 30"		
HR:	86°01' 59"		
N :	0.168 m		
E :	2.430 m		
Z :	1.782 m		
ALL	MEAS	MODE	P1↓
HT	BS	OCC.	P2↓

- 2) Press [F1] (HT) to display the instrument height and target height. Move to "R.HT".

HEIGHT INPUT			
INS.HT:	2.000 m		
R.HT :	<input type="text" value="0.000"/>		
BACK			ENT

- 3) Input target height, and press [F4] (ENT).

HEIGHT INPUT			
INS.HT:	2.000 m		
R.HT :	<input type="text" value="1.500"/>		
BACK			ENT



Inputting range: $-99999999.9999 \leq N, E, Z \leq +99999999.9999$ m

$-99999999.9999 \leq N, E, Z \leq +99999999.9999$ ft

$-99999999.11.7 \leq N, E, Z \leq +99999999.11.7$ ft+inch

10. Data collection

By pressing the MENU, the instrument will be in MENU 1/2 mode. Press 1 (DATA COLLECT)

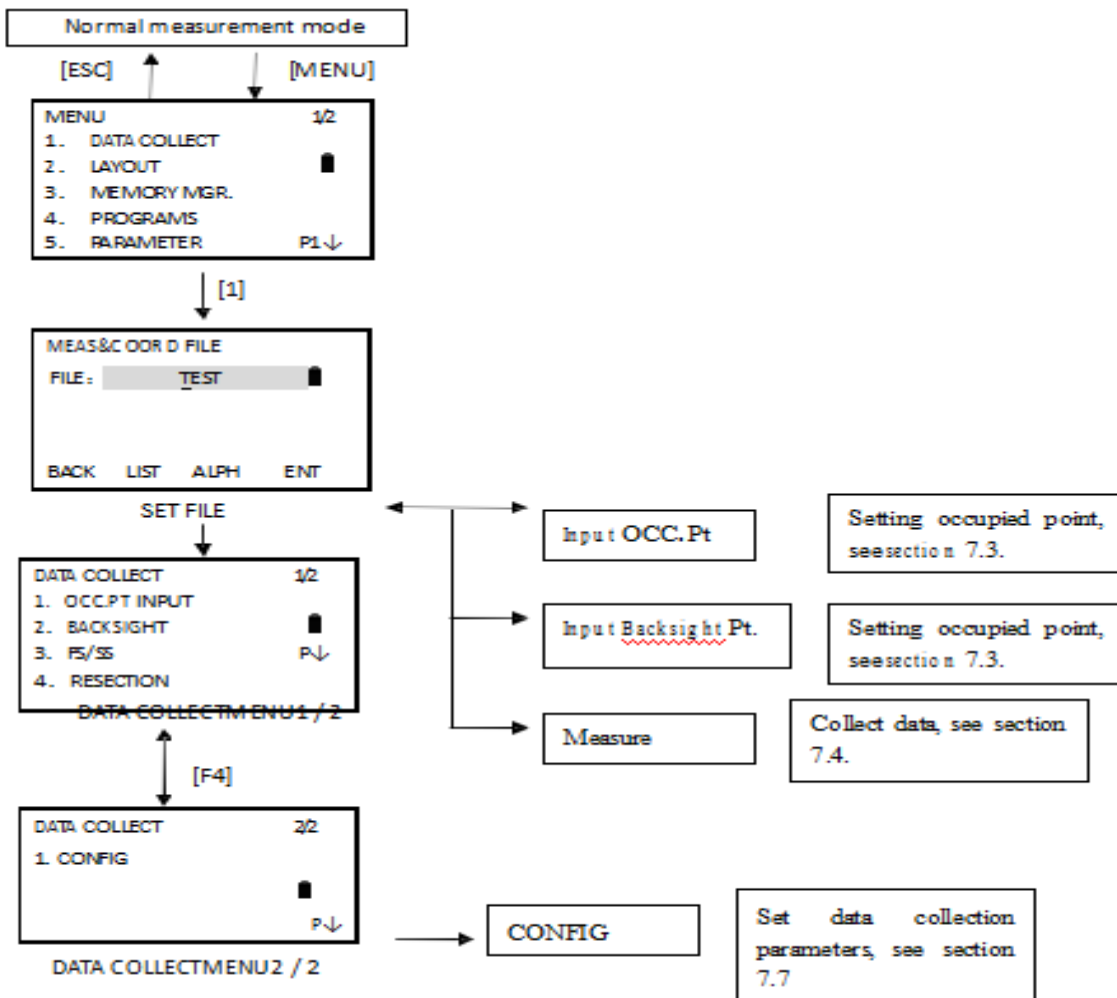

CTS-112R can store the measured data into the internal memory. The internal memory is divided as the measured data files and the coordinate data files.

10.1. Operation procedure

- 1) Select a data collection file.
- 2) Select "REC. coordinate file" and save the coordinate data converted from original data.
- 3) Select coordinate data file so that you can use occupied point coordinate data and backsight coordinate data. (If coordinate data of known point is not necessary for use, pass this step).
- 4) Set occupied point including Instrument height, point number and coordinate.
- 5) Set backsight point, direction and azimuth.
- 6) Start collecting and saving data.

10.2. Selecting a file for data collection

A file used by data collection mode must be selected at first. Then the screen of selection a file is displayed. A selection from data collection menu is possible in the data collecting menu of this mode.

- 1) Press [MENU] to enter MENU1/2, and then press [1] (DATA COLLECT).

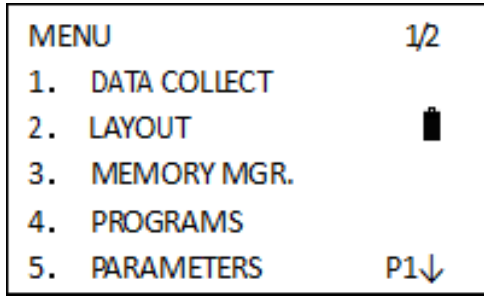

- 2) Press [F2] (LIST).

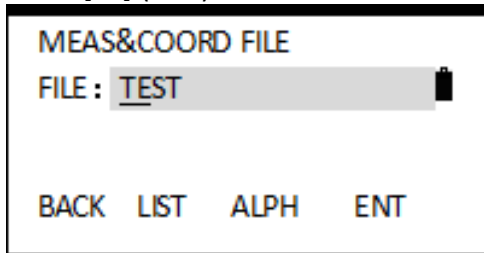

- 3) Press [ENT], success to call out file, and then the screen returns to DATA COLLECT MENU 1/2.

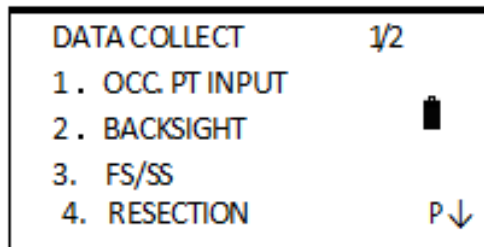

10.3. Occupied point and backsight point

The occupied point and direction angle in the data collect mode are linked with the occupied point and it is possible to set or change the occupied point and direction angle from the data collect mode.

Occupied point can be set by two setting methods as follow:

- Setting from the coordinate data stored in the internal memory
- Direct key input

The following three setting methods for back sight point can be selected:

- Setting from the coordinate data stored in internal memory
- Directly input the coordinate of back sight point
- Directly input the set angle



The setting of azimuth is decided by measurement.

How to save coordinate data into internal memory, please refer to section 14.4 "Load data".

10.3.1. Example for setting the occupied point

In case of setting occupied point from the coordinate data stored in the internal memory.

- 1) In DATA COLLECT Menu 1/2, press [1] (OCC. PT INPUT), then preexisting data are displayed.

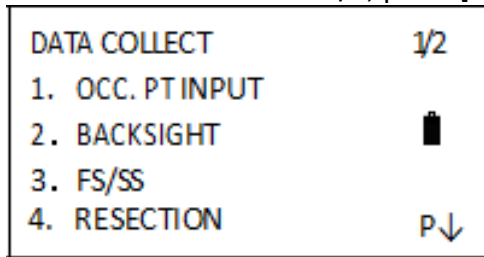

- 2) Press [F4] (ENT).

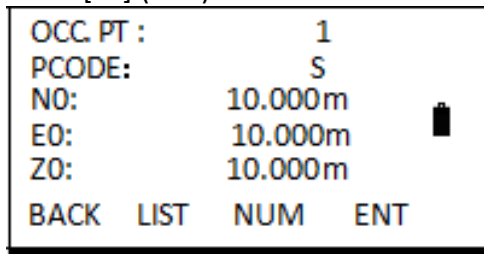

- 3) Press [F4] (INPUT INS.HT).

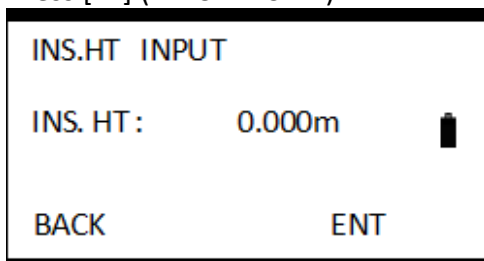

- 4) Press [F3] or [F4] to choose whether need to set Back sight.

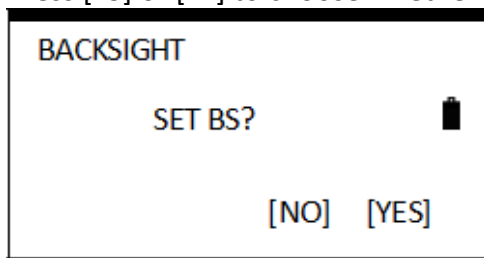

10.4. Data collect offset measurement mode

This mode is useful when it is difficult to set up the prism directly, for example at the center of a tree.

Data collect offset measurement has four measuring methods:

- Angle offset measurement
- Distance offset measurement
- Plane offset measurement
- Column offset measurement

10.4.1. Angle offset measurement

Place the prism at the same horizontal distance from the instrument as that of point A0 to measure. To measure the coordinates of the center position, operate the offset measurement after setting the instrument height or prism height.

- When measuring coordinates of ground point A1: Set the instrument height or prism height
- When measuring coordinates of point A0: Set the instrument height only (set the prism height as 0).

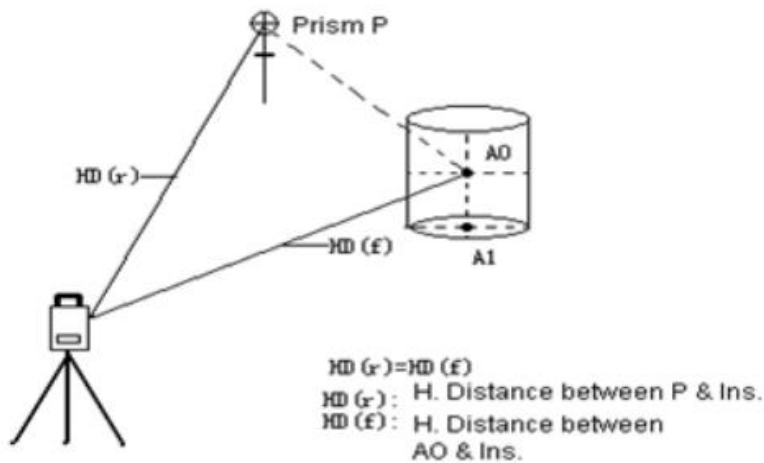

1) In DATA COLLECT → FS/SS mode.

FS/SS
POINT: 5
PCODE → CHC
R. HT: 1.000 m
INPUT VIEW MEAS ALL
ANG. DIST NEZ OFFS

2) Press [F4] (ANG. OFFSET).

Offset
1. ANG. OFFSET
2. DIST. OFFSET
3. PLANE OFFSET
4. COLUMN OFFSET

3) Aim to the prism center, and press [1] (MEAS) to measure.

ANG. OFFSET
HR: 90°00' 05"
SD:
HD:
VD:
MEAS

- 4) Press [F3] or [F4] choose to save or not.

```
ANG. OFFSET
HR:  90°01' 13"
N:    99.999 m
E:    102.328 m
Z:    10.543 m
>REC.?      [NO] [YES]
```

- 5) Rotate horizontal clamp and tangent screw to aim to the target point A0 and display its coordinate.

```
ANG. OFFSET
HR:  159°22' 55"
N:    98.116 m
E:    100.710 m
Z:    10.535 m
>REC.?      [NO] [YES]
```

- 6) If press [DIST], then SD, HD and VD are displayed.

```
ANG. OFFSET
HR:  159°21' 16"
SD:    2.041 m
HD:    2.013 m
VD:    0.335 m
>REC.?      [NO] [YES]
```

- 7) Press [F4](YES), data is recorded, and the next target offset is measured. Press [F4] (NEXT) and redefine ANG. OFFSET. Aim to the prism, and press [F1](MEAS). Press [F3] (CONT), then the basic point remains, and offset measuring of the next point carries on.

```
ANG. OFFSET
HR:  220°54' 57"
SD:
HD:
VD:
MEAS
```

10.4.2. Distance offset measurement

The measurement of a place apart from a prism is possible by inputting offset horizontal distance of front and back, right and left.

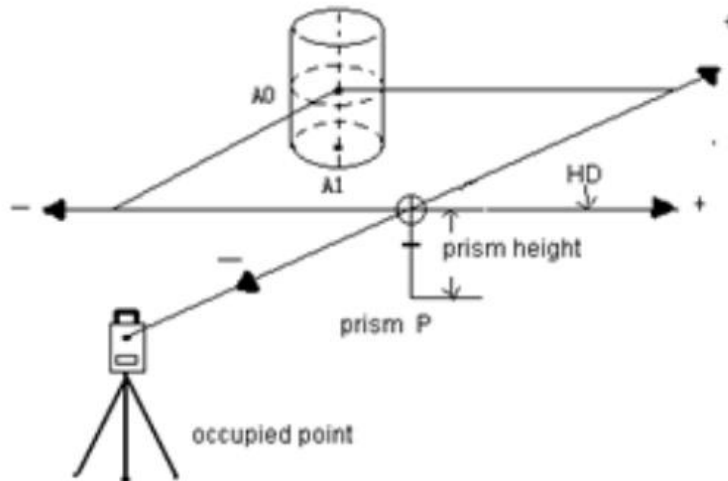

- 1) In the DATA COLLECT →FS/SS mode, press [F3] (MEAS), press [F4] (OFFS) in the prompted function menu.

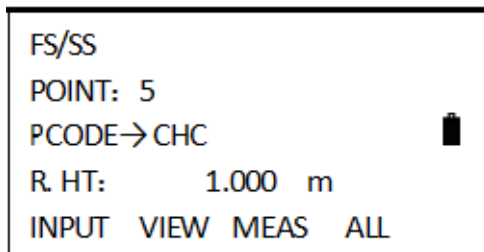

- 2) Press [2] (DIST. OFFSET).

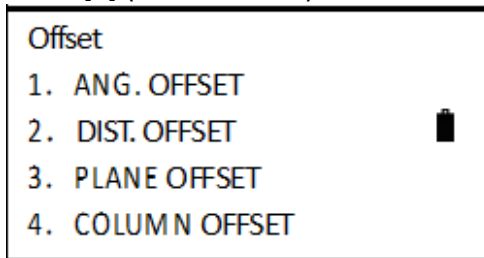

- 3) Input left or right offset value and forward oHD, press [F4] (ENT).

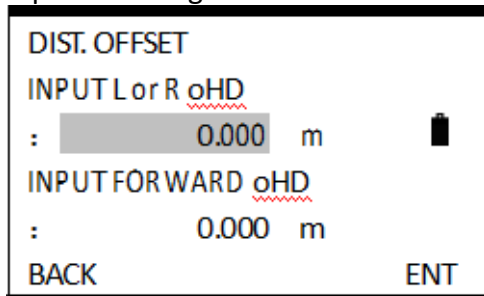

- 4) Aim to the target, press [F1] (MEAS).

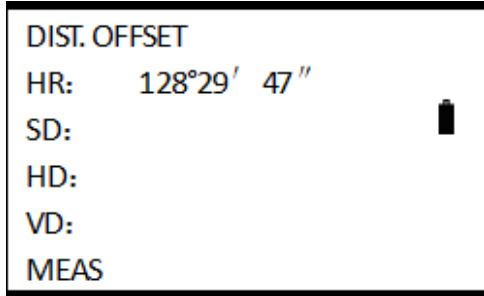

- 5) System runs measurement function. To carry on repeating measurement, press [F4] (SET).

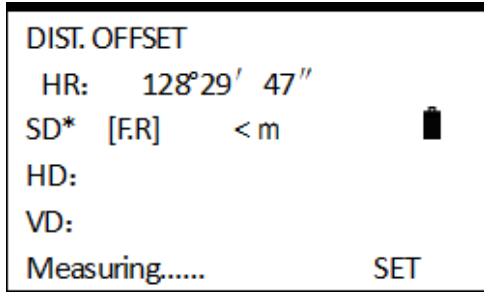

- 6) The result displays when measuring is over, you can press [CORD] to display the coordinates of the target. Press [F4] (YES) to record.

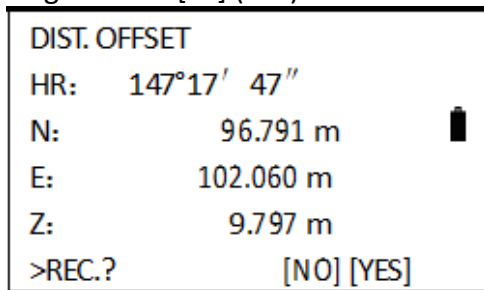

10.4.3. Plane offset measurement

Measurements will be taken for the place where direct measuring cannot be done, for example distance or coordinate measurement for an edge of a plane.

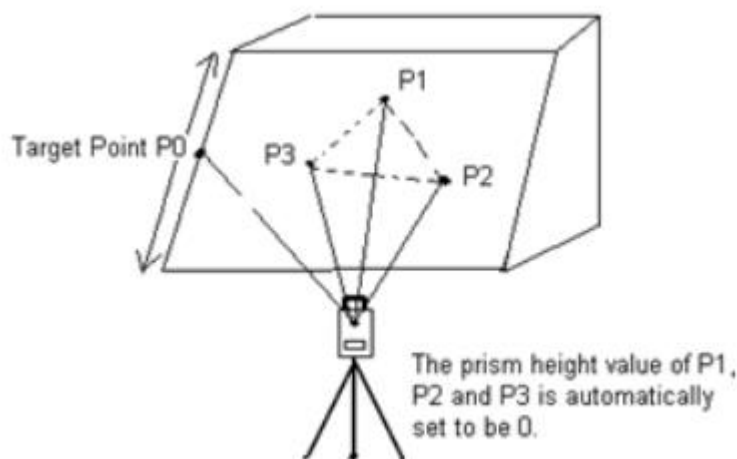

Three random prism points (P1, P2, P3) on a plane will be measured at first in the plane offset measurement to determine the measured plane. Aim to the measuring target point (P0) then the

instrument calculates and displays coordinate and distance value of cross point between collimation axis and of the plane. To set the coordinate value for the occupied station, refer to section 9.2 "Setting coordinates of occupied point".

- 1) Press [F3] (MEAS), press [F4] (OFFS) in the prompted function menu.

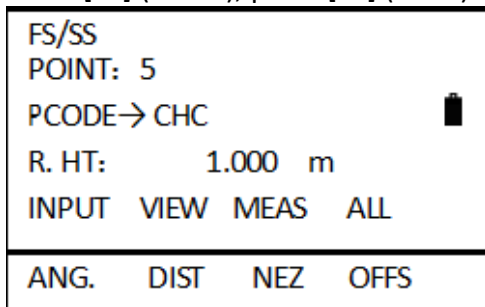

- 2) Press [3] (PLANE OFFSET).

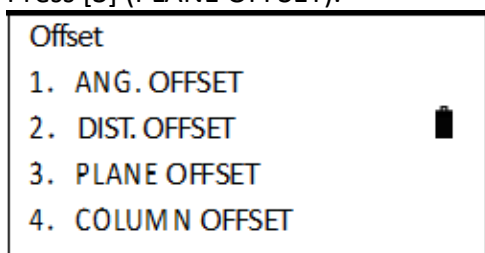

- 3) Collimate prism P1, and press [F1] (MEAS).

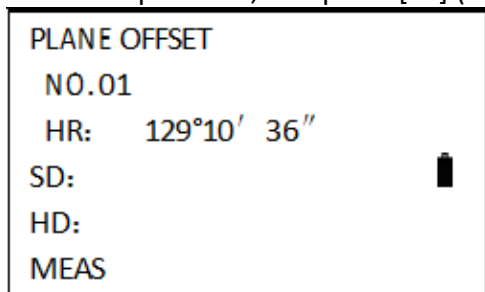

- 4) System runs measurement function. To carry on repeating measurement, press [F4] (SET).

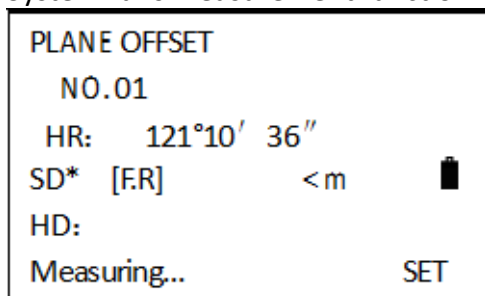

- 5) After measuring, the display indicates measurement to the 2nd point. Measure the 2nd and 3rd point in the same way.

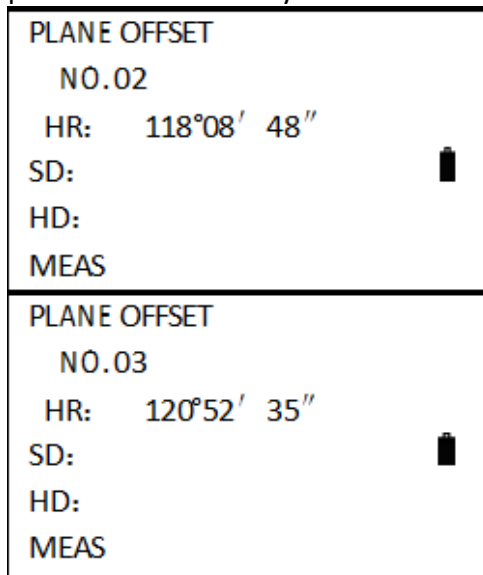

- 6) The result displays when measuring is over.

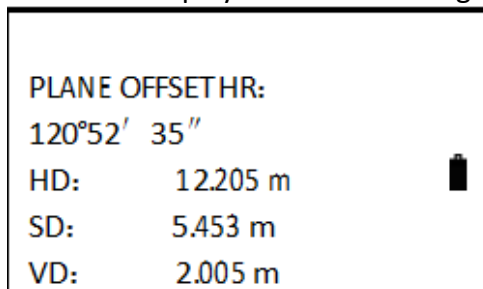

- 7) Press [CORD] to display the coordinates of this point.

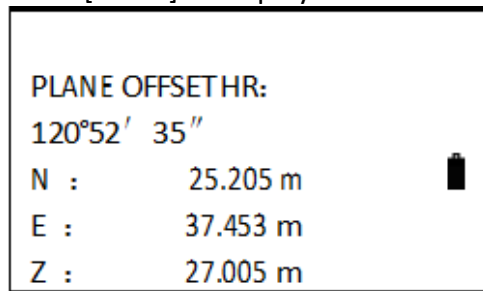

- 8) Press [F4] (YES), measuring data is recorded, and begin to measure the next target point.
9) Press [ESC] to redefine the plane.

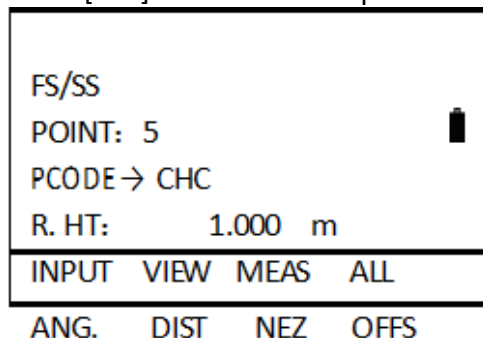



In case the calculation of plane was not successful by the measured three points, error displays. Start measuring over again from the first point:

- Data display is the mode beforehand of offset measurement mode.
- Error will be displayed when collimate to the direction which does not cross with the determined plane.

10.4.4. Column offset measurement

If it is possible to measure circumscription point (P1) of column directly the distance to the center of the column (P0), coordinate and azimuth can be calculated by measured circumscription points (P2) and (P3). The direction angle of the center of the column is 1/2 of total azimuth of circumscription points (P2) and (P3).

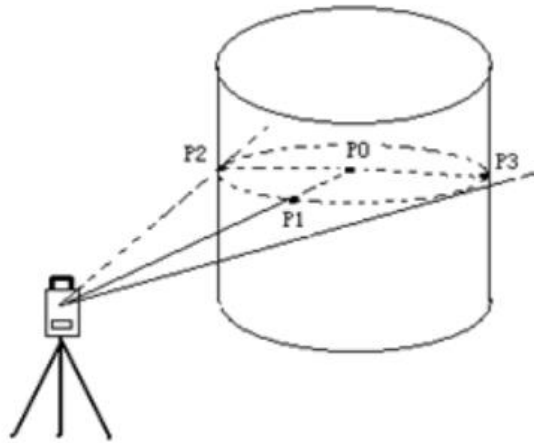

When setting the coordinate value for the occupied station, refer to section 9.2 “Setting coordinates of occupied point”.

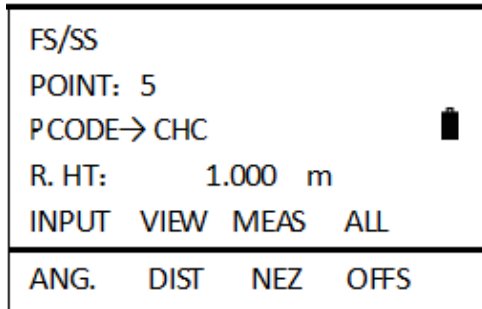

- 1) Press [F3] (MEAS), press [F4] (OFFS) in the prompted function menu.

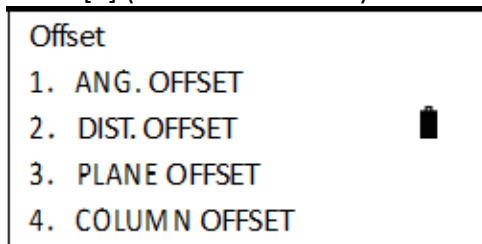

- 2) Press [4] (COLUMN OFFSET).



- 3) Aim the center of the column (P1) and press [F1] (MEAS) to start measuring.

COLUMN OFFSET		
Center		
HR:	170°30' 20"	
SD:		
HD:		
MEAS		
COLUMN OFFSET		
Center		
HR:	170°30' 20"	
SD*	[F.S.]	<- m
HD:		
Measuring.....		

- 4) After the measurement, angle measurement of the left side (P2) will be shown.
5) Collimate the left side of the column (P2) and press F4(SET)

COLUMN OFFSET		
Left		
HR:	170°30' 20"	
SD:	3.793 m	
HD:	3.717 m	
SET		

- 6) After measurement, angle measuring of the right side (P3) will be shown. Aim the right side of the column(P3) and press F4(SET).

COLUMN OFFSET		
Right		
HR:	200°30' 20"	
SD:	3.793 m	
HD:	3.717 m	
SET		

- 7) After measurement, the coordinates of P0 will be calculated and displayed.

COLUMN OFFSET		
HR:	120°30' 20"	
SD:	3.793 m	
HD:	3.717 m	
VD :	24.251 m	
>REC.?	[NO] [YES]	

8) To display coordinates PO point, press [CORD].

```
COLUMN OFFSET
HR:    120°30' 20"
E:     28.025 m
N:     39.390 m
Z:     25.024 m
>REC.? [NO] [YES]
```

9) Press F4 (YES), the data is recorded. Press ESC to exit the column offset mode and return to the previous mode.

```
FS/SS
POINT: 5
PCODE→CHC
R. HT: 1.000 m
INPUT  VIEW  MEAS  ALL
-----
ANG.   DIST  NEZ   OFFS
```

10.5. Setting config of data collection

In DATA COLLECT menu, press F4[P↓] to enter DATA COLLECT 2/2, and then press 2.[CONFIG]

1) NEZ AUTO CALC

During collecting data, choose whether to use the measured data to calculate coordinate data and save into the coordinate file automatically.

2) Collect seq

Set the sequence of data collection and edition. EDIT→MEAS: Set the PT# name, PCODE and target height firstly and then collect data. MEAS→EDIT: Collect data firstly, and then allow the customer to edit the collected PT# name, PCODE, target height.

3) Data confirm

Switch of recording data after collection.

ON: indicates whether to record.

4) SELECT SD/HD

Set the displaying sequence of data collection.

If need to change the setting when collecting data, you should set parameter at first.

11. Stakeout

Stakeout mode has two functions that are setting of stake points and setting new points using coordinate data in the internal memory. The coordinate data for stakeout maybe the points stored in the internal memory, or maybe inputted from keyboard. The coordinate data is loaded from PC to the internal memory via communication cable.

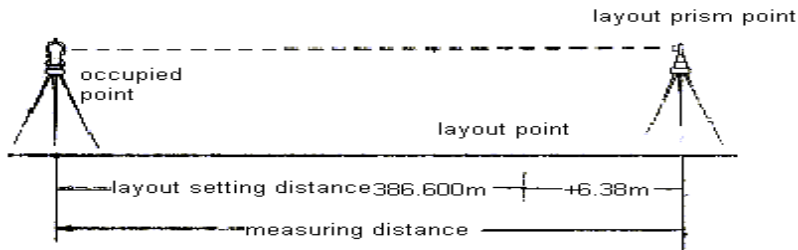

11.1. Stakeout procedure

There are the following steps:

- 1) Selecting stakeout file. You can call up the occupied point coordinate data, backsight coordinate data, and stakeout point data.
- 2) Setting occupied point.
- 3) Setting backsight point and azimuth angle.
- 4) Input stakeout point coordinates, and then starts.

11.2. Preparation

11.2.1. Setting the grid factor

Calculation Formula

- Elevation factor = $R / (R + \text{ELEV})$ R: The average radius of the earth ELEV: The elevation above mean sea level
- Scale factor in the surveying station
- Grid factor = Elevation factor \times Scale factor

Distance calculation

- $\text{HDg} = \text{HD} \times \text{Grid factor}$
HDg: Grid distance
HD: Ground distance
- Ground distance
 $\text{HD} = \text{HDg} / \text{Grid factor}$

How to set grid factor?

- 1) Press [MENU] -> [5] PARAMETERS-> [3] OTHER SET -> [F4] Page2 -> [5] GRID FACTOR.

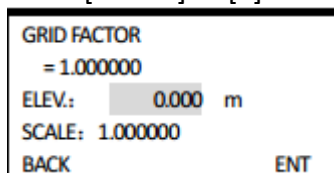

2) Input elevation, press [F4](ENT).

```
GRID FACTOR
= 1.000000
ELEV. : 2000.0 m
SCALE: 1.000000
BACK ENT
```



Input elevation: -9999 to +9999m(-32805 to +32805ft.)
Scale factor: 0.990000 to 1.010000

3) Enter scale factor in the same way.

```
GRID FACTOR
= 0.999686
ELEV. : 2000.000 m
SCALE: 0.999000
BACK ENT
```

4) The system calculates out the grid factor, press [F4] (ENT), then the display returns to LAYOUTMENU2/2.

```
GRID FACTOR
= 0.998687
ELEV. : 2000.000 m
SCALE: 0.999000
BACK ENT
```

11.2.2. Selecting coordinate data file

You can execute a stakeout from selected coordinate data file, also you can record new point measured data into the selected coordinate data file. When STAKEOUT MODE begins, a file can be selected in the same way.

11.2.3. Setting occupied point

Occupied point can be set by two setting methods as follow:

- Setting from the coordinate data stored in the internal memory
- Direct input of coordinate data

Example: setting the occupied point from the internal coordinate data file.

1) Press the [1] (OCC.PT INPUT) from the Layout menu 1/2.

```
LAYOUT
1.OCC. PT INPUT
2.BACKSIGHT
3.LAYOUT PT
4.SIDE SHOT
```

2) Input point 1, and then press [F4] (ENT).

```
OCC. PT : 1
PCODE: S
NO: 10.000m
EO: 10.000m
ZO: 10.000m
BACK LIST NUM ENT
```

3) Input INS.HT and press [F4] ENT.

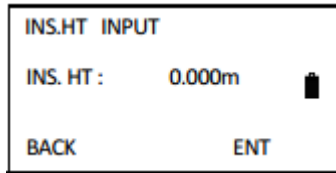

4) Press [F3] or [F4] to choose whether need to set backsight.

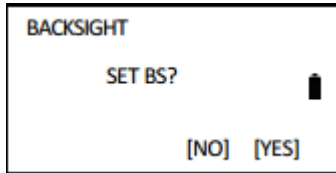

5) Press [ENT], success to call out file, and then the screen returns to DATA COLLECT MENU 1/2.

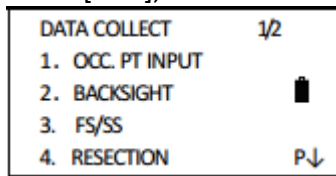

11.2.4. Setting backsight point

The following three setting methods for Backsight point can be selected:

- Setting from the coordinate data file stored in the internal memory.
- Direct input of coordinate data.
- Direct input of setting angle.

Example: Setting the backsight point from the internal coordinate data file

1) Press [2] (BACKSIGHT) in LAYOUT menu.

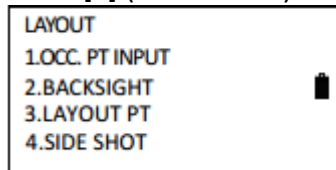

2) Press [1](BS COORD).

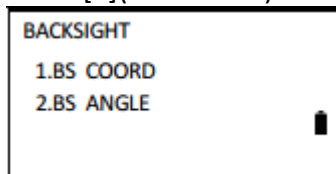

3) Display the coordinate of this point. Press [F4] (YES) and the display shows the azimuth.

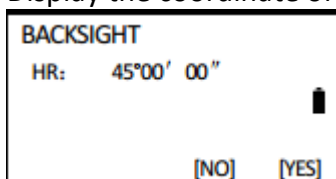

- 5) Aim to the backsight point, and press [F4] (YES) to show "Set". In two seconds, the display returns to LAYOUT menu 1/2.

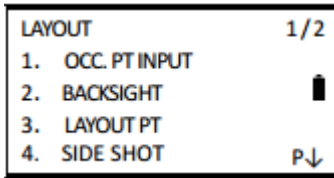

11.3. Setting a new point

New point is required, for example, when a layout point cannot be sighted from existing occupied points.

11.3.1. Side shot method

Set up the instrument at a known point and measure the coordinate of the new points by this side shot method.

- 1) Press [4] in LAYOUT Menu choose SIDE SHOT.

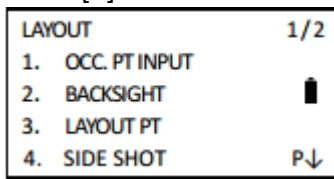

- 2) Press [F1] to input new point name, code and R.HT.

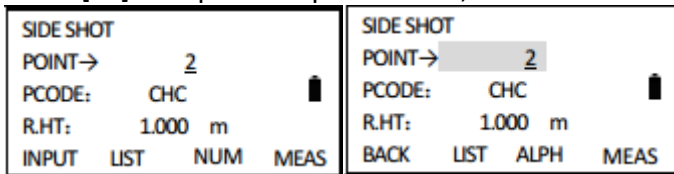

- 3) Aim to new point and press [F4] (MEAS) to measure.

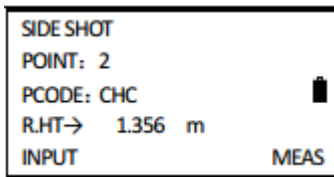

- 4) Measure the target.

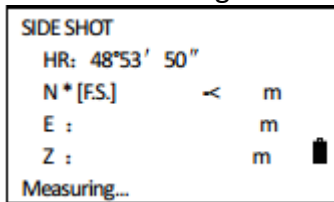

5) After measuring, the coordinate will be shown. Press [F4] (YES) to record. Point # and coordinates will be saved into coordinate data file. The next new point inputting menu displays, point# adding 1 automatically.

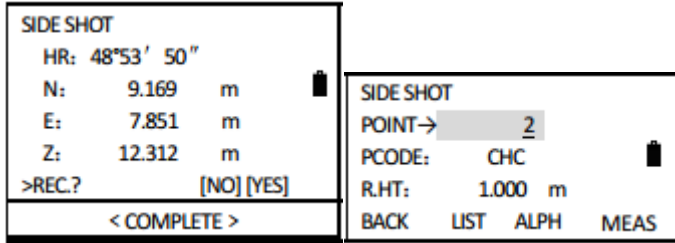

File can be input directly, press [F4] (ENT) to confirm.
 For Instruction of disk , please refer to section 14 “Memory management”.
 Press [F2](SRCH), enter the file name directly to launch the required COORD. FILE.
 Press [F3](EXIT), Display back to LAYOUTMENU.
 Refer to section 6.7 “Method of inputting, alphanumeric characters”.
 When the memory room is full, error message will display.

11.3.2. Resection method

Set up the instrument at a new point and calculate the coordinate of the new point using the coordinate data for maximum seven known points and the measurement made to these points. By following observation, resection is possible.

- Resection by distance measurement: 2 or more points must be measured.
- Resection by angle measurement: 3 or more points must be measured.
- Resection by angle measurement and distance measurement cannot be used together. When using resection by angle measurement, the direction of known points should be clockwise or anti-clockwise, and the angle between two points should not exceed 180.

An occupied point coordinate value will be calculated by the method of least squares. (In case that 3 known points are measured by angle measurement only, the value would not be calculated by the method of least squares).

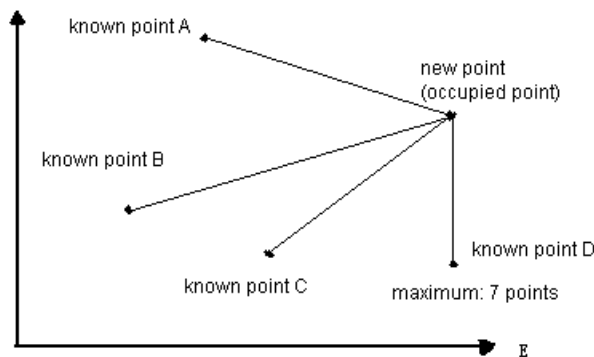

1) [F4] (P↓) from LAYOUTMENU1/2 to enter LAYOUT Menu 2/2, press [1] (RESECTION).

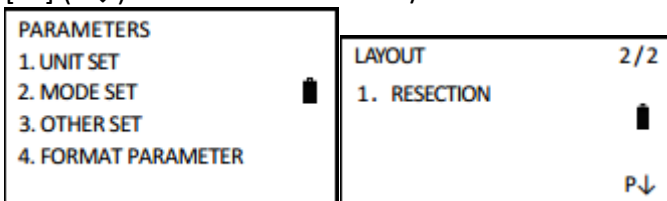

- 2) Press [F1](INPUT).

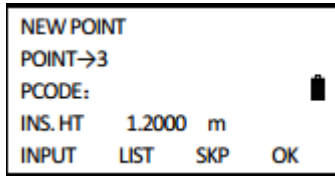

```
NEW POINT
POINT→3
PCODE:
INS. HT 1.2000 m
INPUT LIST SKP OK
```



If there is no need to save the new point data, press [F3](SKP) and start from step 5.

- 3) Enter the new point name, Pcode and instrument height. Press [F4] (ENT).

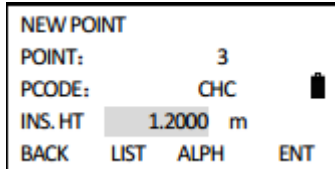

```
NEW POINT
POINT: 3
PCODE: CHC
INS. HT 1.2000 m
BACK LIST ALPH ENT
```



Refer to section 6.7 “Method of inputting, alphanumeric characters”.

- 4) System indicates to enter name of the target point, press [F1] (INPUT).

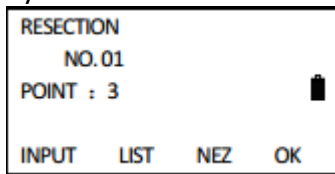

```
RESECTION
NO. 01
POINT : 3
INPUT LIST NEZ OK
```

- 5) Enter the point# of point A, and press [F4] (OK).

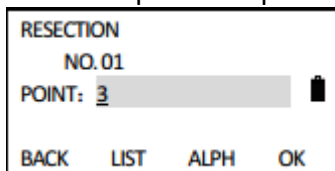

```
RESECTION
NO. 01
POINT: 3
BACK LIST ALPH OK
```



To enter the known point coordinate data, press [F3](NEZ).

- 6) The coordinates of the point display. Press [F4] (YES) to confirm.

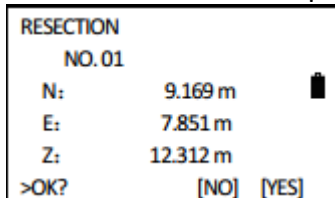

```
RESECTION
NO. 01
N: 9.169 m
E: 7.851 m
Z: 12.312 m
>OK? [NO] [YES]
```

- 7) The display indicates to enter target height, press [F4] (ENT) after inputting.

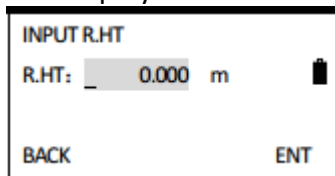

```
INPUT R.HT
R.HT: 0.000 m
BACK ENT
```

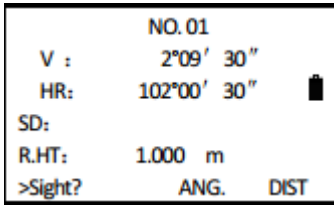

8) Aim the known point A and press [F3] (ANG.) or [F4](DIST). E.g. [F4] (DIST).

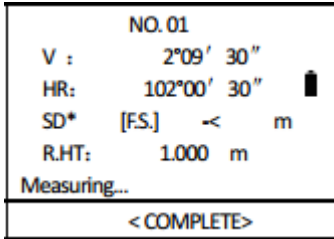

9) Start to measure.

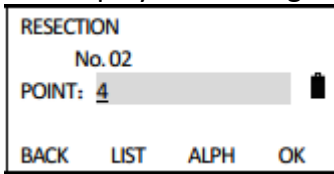

10) The display of entering known Point B shows.



11) Do the same as step 6-11 to measure point B, after using "DIST" to measure two known points, the residual error will be calculated.

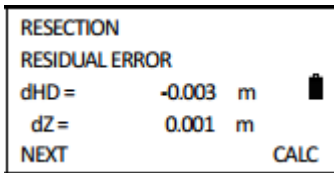

Residual error

- dHD (Horizontal distance between two known points) = Measured value - Calculated Value.
- dZ (Z coordinate of the new point calculated from known point A) - (Z coordinate of the new point calculated from known point B)

12) Press [F1](NEXT) to measure other known points. Maximum 7 points.

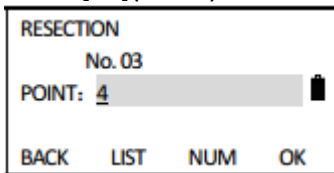

13) From step 6-11, known point C has been calculated. Press [F4] (Calc) to view results of resection.

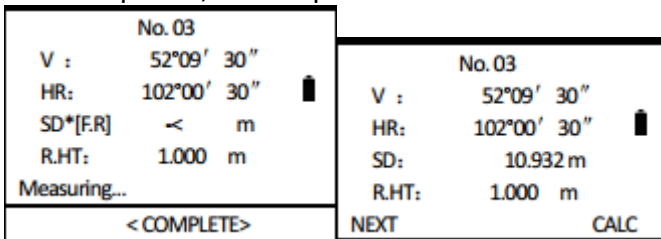

14) Display the standard deviation of the coordinate. Unit:(mm)

```
SD(n) = 4 mm
SD(e) = -6 mm
SD(z) = 1 mm
NEZ
```

15) Press [F4] (NEZ) to view coordinate of new points. Press [F4](YES) to record the data.

```
N: 12.322 m
E: 34.286 m
Z: 1.5772 m
>REC.? [NO] [YES]
```



If press [F3](SKP) in step 2, the new point data is not stored into the coordinate data file, only the value of occupied coordinate data is replaced by that of the calculated new point.

16) Coordinate of new point is saved into coordinate data file and the occupied point data will change to that of the calculated New Point. The system returns to layout menu.

```
LAYOUT 2/2
1. RESECTION
P↓
```

12. Measurement program mode

Press MENU key, and instrument will entry to menu mode. In this mode, you can set and check.

12.1. Remote height measurement (REM)

To obtain the target height in which user cannot lay prism, just lay the prism in any point above target on the plumb line, and then start REM.

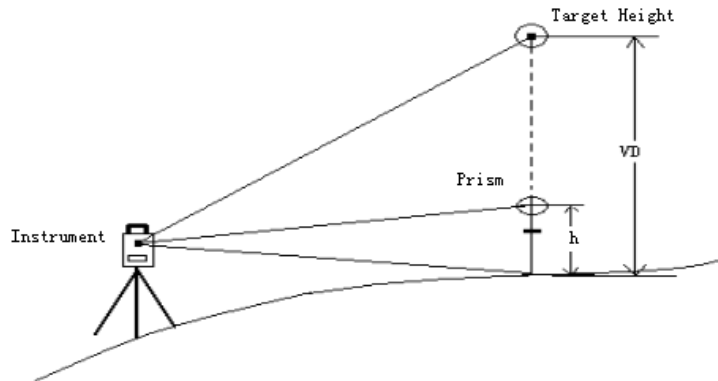

12.1.1. Known prism height (e.g. $h = 1.3$ m)

- 1) Press [MENU] and then [4] to enter PROGRAMS function.

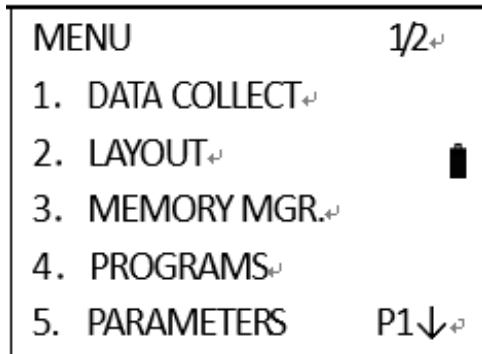

- 2) Press [1] (REM).

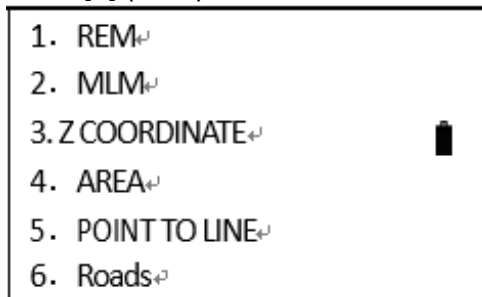

- 3) Press [1] and select the REM mode that requires inputting prism height.

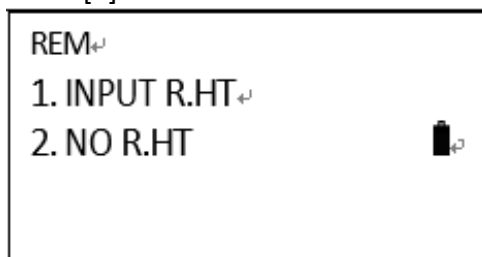

4) Input prism height, and press F4 (ENT).

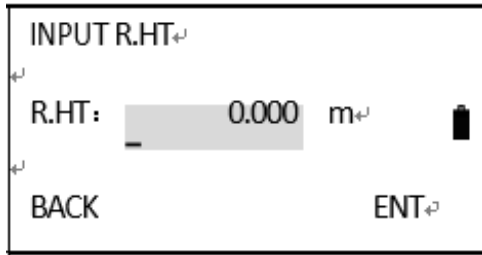

Refer to section 6.7 "Method of inputting, alphanumeric characters".

5) Collimate the prism, and press [F1] (Measure) to start measurement.

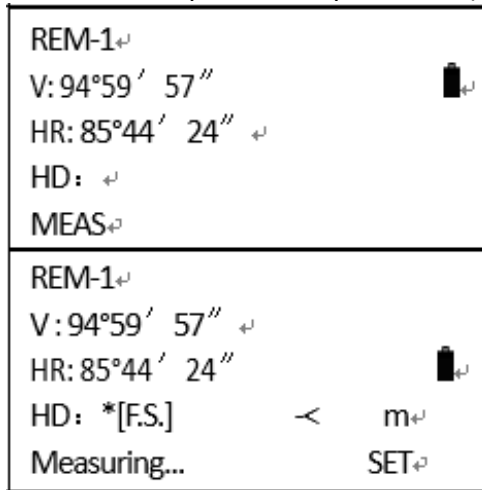

6) The position of prism was confirmed and displayed as right figure.

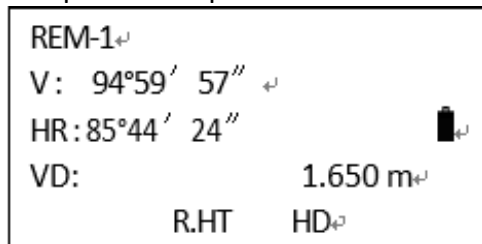

7) Aim to target K and display the vertical distance (VD) from prism center to target point.

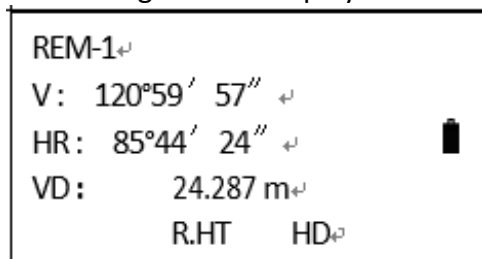

Press [F2](R.HT) to return to step d, and press [F3](HD) to return to step 5.
Press [ESC] to return to program menu.

12.1.2. When prism height is unknown

- 1) Press [2] to select the REM function which doesn't require to input prism height.

```
REM↵
1. INPUT R.HT↵
2. NO R.HT↵
```

- 2) Aim to prism center, and press [F1] (MEAS).

```
REM-2↵
<STEP-1>↵
V: 100°59' 57"↵
HR: 85°44' 24"↵
HD:↵
MEAS↵
```

- 3) System starts to measure.

```
REM-2↵
<STEP-1>↵
V: 100°59' 57"↵
HR: 85°44' 24"↵
HD* [F.3] < m↵
Measuring... SET↵
```

- 4) When the measurement is finished, display the horizontal distance between instrument and prism.
Press F4 (SET)

```
REM-2↵
<STEP-2>↵
V: 73°59' 57"↵
HR: 85°44' 24"↵
HD: 2.2999 m↵
SET↵
```

- 5) The position of prism is confirmed, press [F4] (SET)

```
REM-2↵
V: 73°13' 57"↵
HR: 44°44' 24"↵
VD: 0.000 m↵
V HD↵
```

6) Aim to ground point G, the position of GIS confirmed.

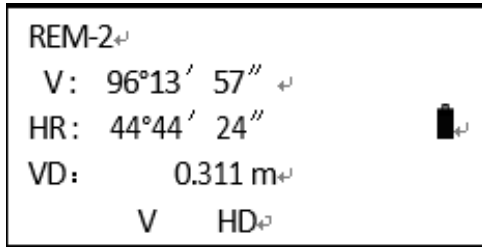

Press F3 (HD) key to return to step b; and press F2 (V) to return to step 5.

7) Collimate target point K and display the height difference(VD).

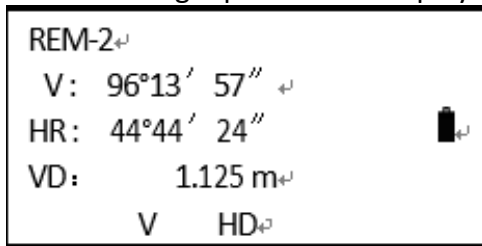

Press [ESC] to return to procedure menu.

12.2. Tie distance

Measure dHD, dSD, dVD and HR between two prisms. Also calculate by inputting coordinate value or list coordinate data file. There are two options for Tie distance:

- MLM-1 (A-B, A-C): measure A-B, A-C, A-D
- MLM-2 (A-B, B-C): measure A-B, B-C, C-D

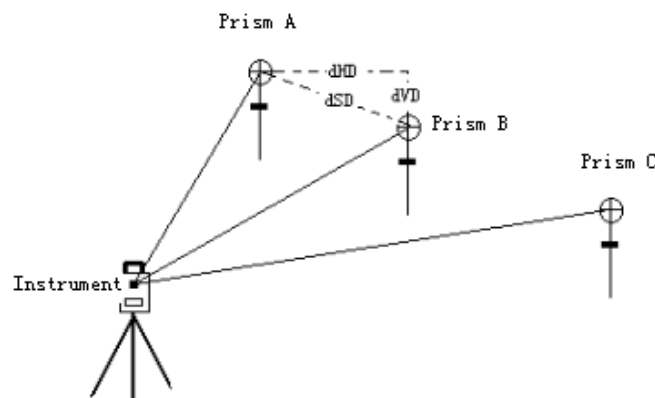

12.2.1. MLM-1 (A-B, A-C)

The measuring process of MLM-2 (A-B, B-C) mode is totally the same as MLM-1 mode.

1) Press [2] in program menu and select MLM.

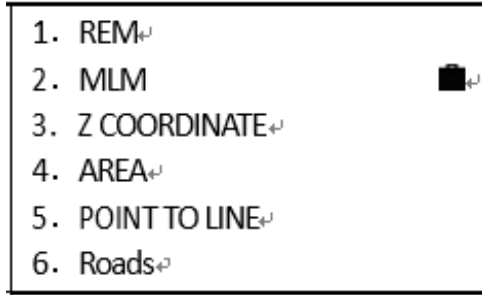

2) Press [1] to select MLM function of A-B, A-C.

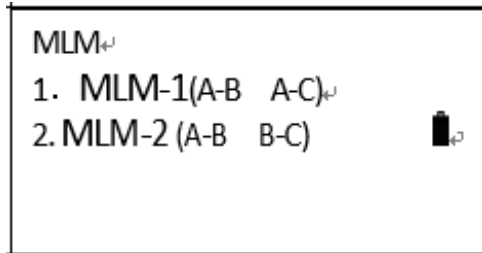

3) Aim to prism A, and press [F1](MEAS).

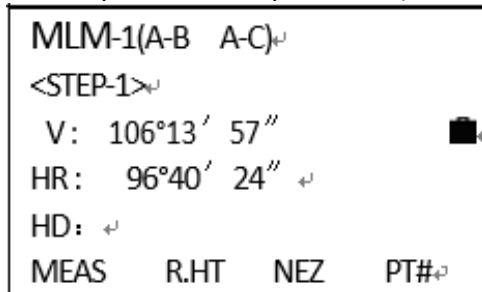

If the coordinate of target point is known, you can press F3 (NEZ) to enter it manually.

4) The HD from instrument to prism A is displayed after measurement.

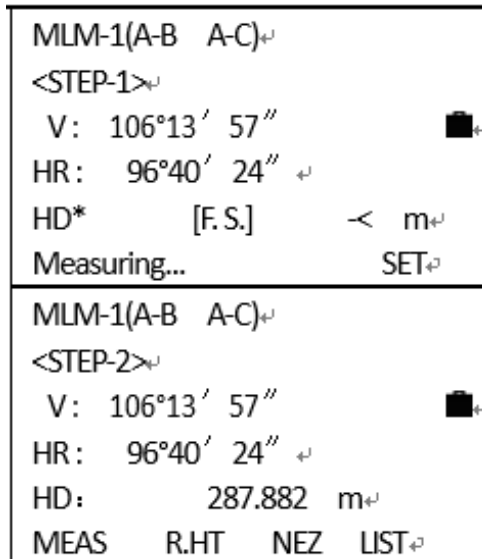

5) Aim to prism B, and press [F1] (MEAS).

```
MLM-1 (A-B A-C)↵
<STEP-2>↵
V: 106°13' 57" ↵
HR: 85°01' 24" ↵
HD: ↵
MEAS R.HT NEZ LIST↵
```

6) The HD from instrument to prism B is displayed after measurement.

```
MLM-1 (A-B A-C)↵
<STEP-2>↵
V: 106°13' 57" ↵
HR: 85°01' 24" ↵
HD*[F.S.] < m ↵
Measuring... SET↵
MLM-1 (A-B A-C)↵
<STEP-2>↵
V: 106°13' 57" ↵
HR: 85°01' 24" ↵
HD: 223.846 m↵
MEAS R.HT NEZ LIST↵
```

7) System calculates dSD, dHD and dVD between prism A and prism B according to the positions of points A and B.

```
MLM-1(A-B A-C)↵
dSD: 263.376 m
dHD: 21.416 m
dVD: 1.256 m↵
HR= 10°09' 30" ↵
NEXT↵
```

8) Press F1 (NEXT) to measure distance between A-C.

```
MLM-1 (A-B A-C)↵
<STEP-2>↵
V: 106°13' 57" ↵
HR: 85°01' 24" ↵
HD: ↵
MEAS R.HT NEZ LIST↵
```



If the coordinate of target point is known, you can press F3 (NEZ) to enter it manually.

- 9) Aim to prism C, and press [F1] (MEAS). The HD from instrument to prism C is displayed after measurement.

```

MLM-1 (A-B A-C)↵
<STEP-2>↵
V: 106°13' 57"
HR: 85°01' 24" ↵
HD:↵
MEAS  R.HT  NEZ  LIST↵
  
```

- 10) System calculates dSD, dHD and dVD between prism A and prism C according to the positions of points A and C.

```

MLM-1 (A-B A-C)↵
dSD:          0.774 m
dHD:          3.846 m
dVD:          12.256 m↵
HR = 86°25' 24" ↵
NEXT↵
  
```

- 11) Measure the distance between A-D, and repeat operation steps 9-10.



Press [ESC] to return to MLM menu.

12.2.2. Using coordinate file

It is possible to input coordinate value directly or calculate from coordinate data file.

- 1) Press [ENT] to use SELECT COORD. FILE, and then press [F3] (NEZ) to display the entering screen of NEZ in the right graph.

```

MLM-1 (A-B A-C)↵
<STEP-1>↵
V: 106°13' 57"
HR: 85°01' 24" ↵
HD: ↵
MEAS  R.HT  NEZ  LIST↵
-----
MLM-1 (A-B A-C)↵
N: 0.000 m↵
E: 0.000 m
Z: 0.000 m↵
BACK          HD  ENT↵
  
```



If the coordinate of target point is known, you can press F3 (NEZ) to enter it manually.

Press [F3] (HD) to return to MLM menu.

- 2) Press [F4] (PT#), the screen shows as the right graph. Press [F2] (LIST) to read coordinate from coordinate data file.

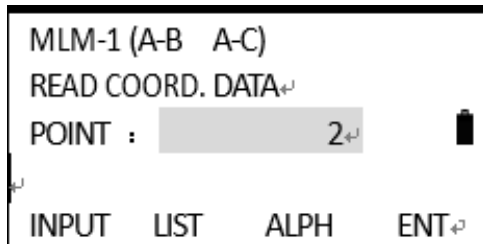

12.3. Set Z coordinate of occupied point

Occupied point coordinates data and known point actual measuring data are utilized Z coordinate of occupied point is calculated and reset again. Coordinate data file can be used as known point data and coordinate data.

12.3.1. Set Z coordinate occupied point using coordinate data file

- 1) Press [3] (Z COORDINATE) in Programs menu.

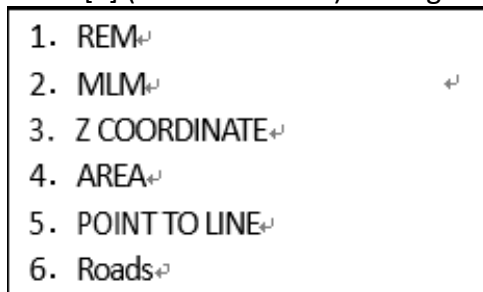

- 2) Press [ENT] or [ESC] to select whether to use coordinate file or not (e.g.: USE).

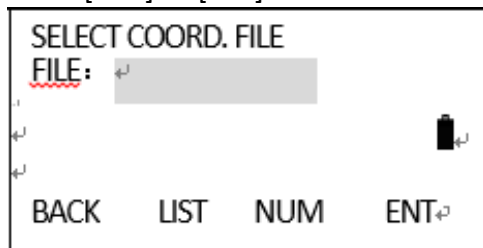

Press [F2] (LIST) to call up coordinate data from current file as occupied point;

Press [F3] (NEZ) to input the coordinate data manually.

3) Input the file name, then press [F4](ENT). Or press [F2] (LIST) to list files in the memory.

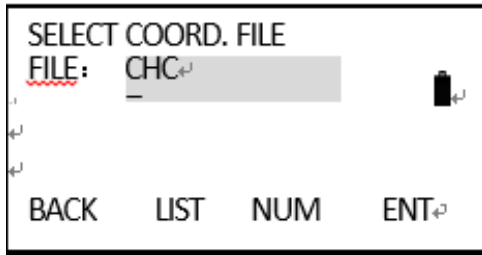

4) Press [1] (OCC. PT INPUT).

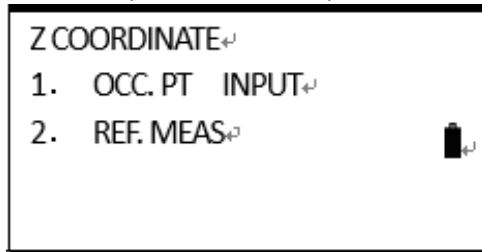

5) System searches this LIST and displays its coordinate, press [F4] to confirm.

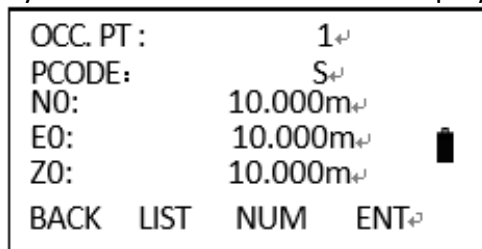

6) Enter the prism height and press [F4] (ENT).

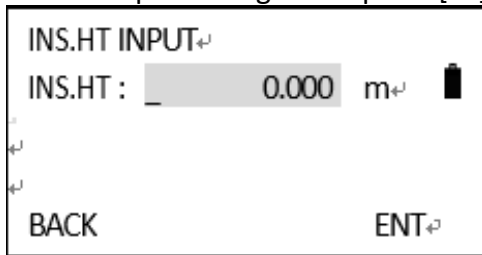

7) Return to the Z COORDINATE menu.

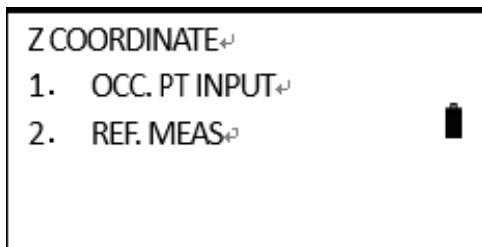

12.3.2. Set Z coordinate of occupied point without coordinate data file

1) Press [3] (Z COORDINATE) in programs menu.

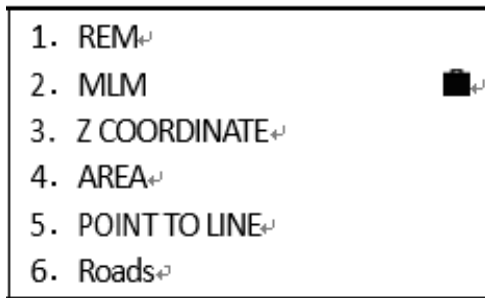

2) Press [ENT] or [ESC] to select whether to use coordinate file or not (e.g.: [ESC], don't use).

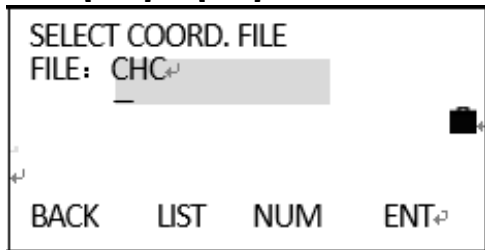

3) Press [2] (REF. MEAS).

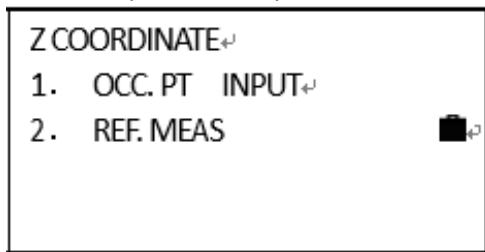

4) Input the coordinate of the point to be measured, and press [F4] (OK).

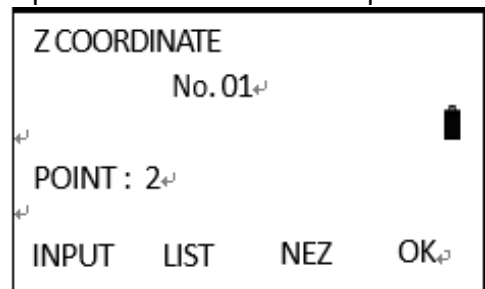

5) The calculating result is displayed. Press [F4] (SET), coordinates of occupied point was set.

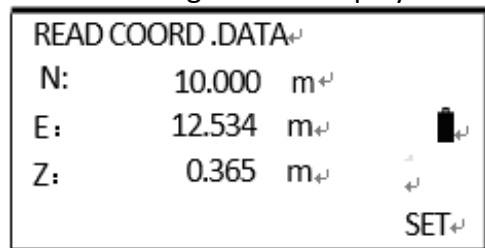

Press [F1] (NEXT) to measure other points, using several points to calculate coordinates.

6) Return to Z COORDINATE menu.

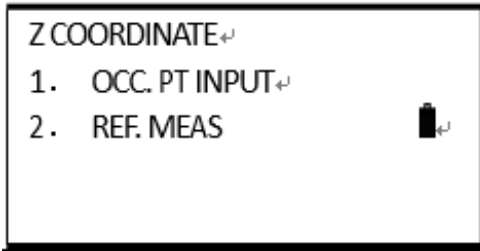

12.4. Area calculation

This mode calculates the area of a closed figure. There are two area calculation methods as follows:

- Area calculation from coordinate data file
- Area calculation from measured data



Area is not calculated correctly if enclosed lines cross each other.

It is impossible to calculate what a mix of coordinate file data and measured data. The number of points used to calculate is not limited.

12.4.1. Area calculation from coordinate data file

1) After pressing MENU key, press [4] to enter PROGRAMS menu.

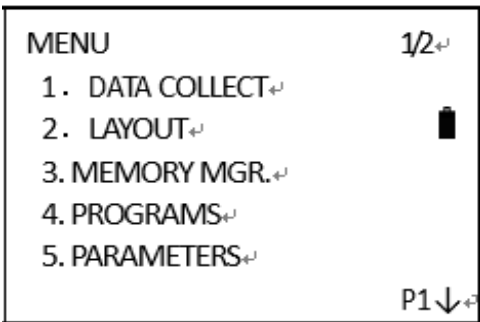

2) Press [4] (AREA).

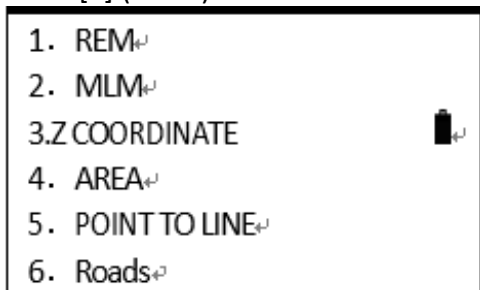

3) Press [ENT] or [ESC] to select whether to use coordinate file or not (e.g.: USE). After inputting file name directly, press [F4] (ENT).

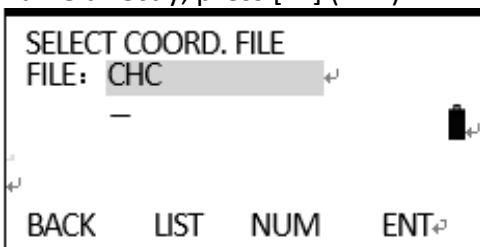

4) The display of area calculation is shown.

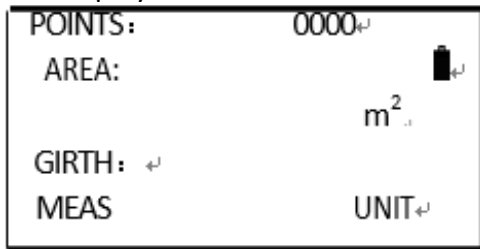

5) Press [F1] to measure points, at least 3 points connect as an area. Above 3 points, the interface can show the area result. You can continue measure, it will calculate all points area result.

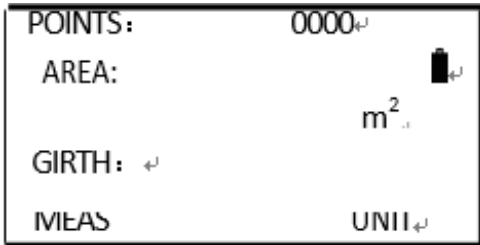

12.4.2. Change the display unit

It is possible to change the display area unit.

1) Press [F3] (UNIT).

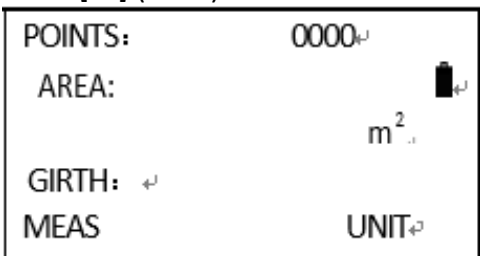

2) Press [F1]-[F4] to select a UNIT. e.g.: press [F2](ha).

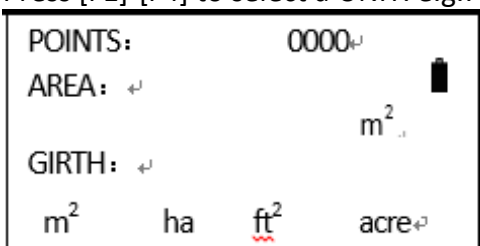

3) The UNIT has been changed.

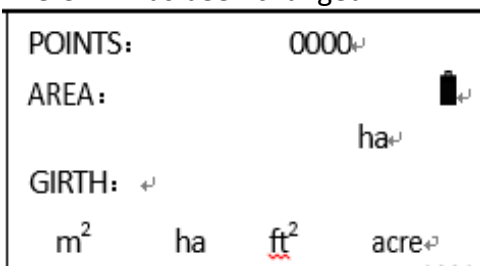

12.5. Measurement REOM point to line

This mode is used to obtain the coordinate data with the origin A (0, 0, 0) and the line AB as N axis. Place the 2 prisms at the A and B on the line, and place the instrument at unknown point C. After measuring the 2 prisms, the coordinate and the azimuth of the instrument will be calculated and recorded.

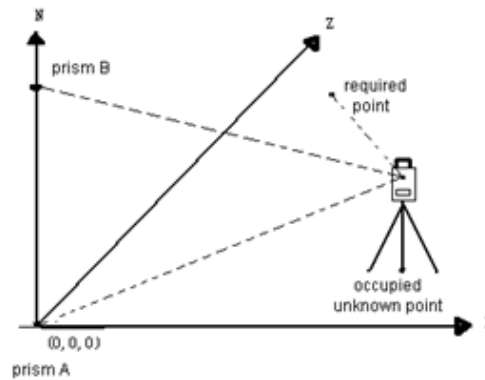

- 1) Press [MENU] and then [4] to enter PROGRAMS menu.

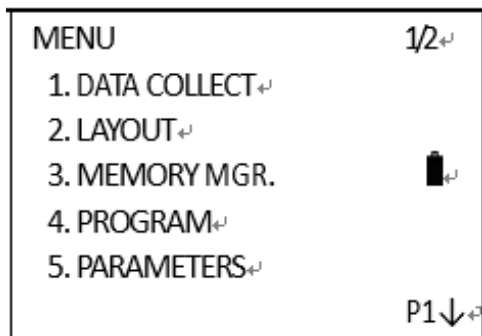

- 2) Press [5] (POINT TO LINE).

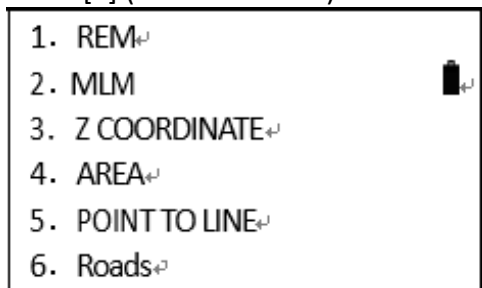

- 3) Aim to the prism P1(Origin), and press [F1] to measure.

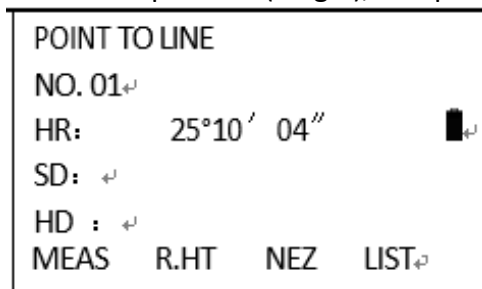

4) System starts to measure.

```

POINT TO LINE↵
NO. 01↵
HR:    225°00' 00"  █
SD* [F. 3]    <m
HD:  ↵
Measuring.....↵
    
```

5) The interface will show the result.

```

POINT TO LINE↵
DIST (P1-P2)↵
dSD:    2.114m  █↵
dHD:    2.114m↵
dVD:    -0.016m↵
NEZ                                OCC.↵
    
```

6) Press [F4] (OCC.) to display the new coordinate of the occupied point.

```

POINT TO LINE
DIST (P1-P2)↵
dSD     5.071 m  █
dHD:    5.071 m↵
dVD:    -1.032 m↵
NEZ                                OCC.↵
    
```

7) Press [F4] (P1P2↓), Display dSD.

```

POINT TO LINE
OCC. PT↵
NO:      0.000 m  █↵
EO:      5.110 m↵
ZO:     -11.035 m↵
                                P1P2↵
    
```

8) Press [F1] (NEZ) to measure other targets.

```

POINT TO LINE↵
DIST (P1-P2)↵
dSD:    5.071 m  █
dHD:    5.071 m↵
dVD:    -1.032 m↵
NEZ                                OCC.↵
    
```

```

POINT TO LINE↵
HR:    225°00' 00"  ↵
N :                                █↵
E :  ↵
Z :  ↵
EXIT                                R.HT  MEAS↵
    
```

13. Parameters

You can set unit and measuring mode in the menu of PARAMETERS, in MENU press "5" to enter PARAMETERS.

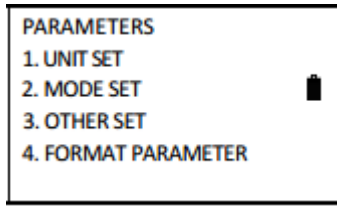

Unit Set

Name	Description
FEET:	Select the standard of FEET. International feet: 1m=3.280839895013123ft USA feet: 1m=3.28033333333333ft
ANGLE:	Select angle unit. DEG/GON/MIL (degree/gon/mil)
DISTANCE:	Select distance unit: m / ft / ft+in(meter/feet/feet-inch)
TEMP. & PRESS:	Select temperature unit: °C / °F Select pressure unit: hPa /mmHg/inHg

Mode set

Name	Description
POWER ON MODE:	Choose to enter angle, distance or coordinates measuring mode after power on
DIST. MODE:	Choose the distance mode after power on, fine[s], fine[n], fine[r], or tracking
NEZ/ENZ:	Choose the coordinates displaying order NE/Z or EN/Z
V.ANGLE Z0/H0:	Choose the reading of vertical angle, from zenith or horizontal.

Other set

Name	Description
Min angle read:	Set the minimum reading of angle unit
Min Dist read:	Set the minimum reading of distance unit
Face in L or R:	Set auto power off ON: If NO key is pressed or no measurement is launched in 30 minutes, the total station will be off automatically
Auto power off:	Set auto power off ON: If NO key is pressed or no measurement is launched in 30 minutes, the total station will be off automatically
H-Angle buzzer:	When the horizontal angle exceeds 90°, whether the buzzer is activated
Meas buzzer:	When there's reflecting signal, whether the buzzer is activated
W-correction:	Settings of atmospheric refraction and curvature correction
Date&Time:	Set the date and time
COMM.PARAMETERS:	Set RS-232C parameters
GRID FACTOR:	Set grid factor

14. Memory management

You can implement the following applications under Memory management. Menu list of Memory management:

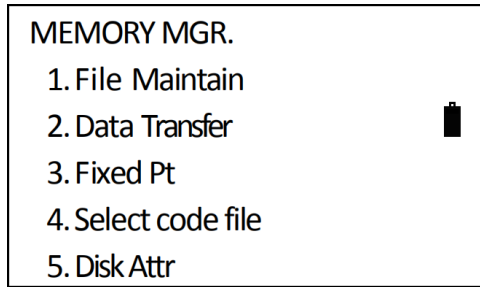

14.1. File maintains

This function can check the memory status, format the memory, and modify file name/search for data in the file/delete files/create new files/edit files.

14.1.1. Setting the atmospheric correction value directly

- 1) Press [MENU] to enter to 1/2 of main page. Press [3] (MEMORY MGR.) to display the menu of MEMORY MGR.

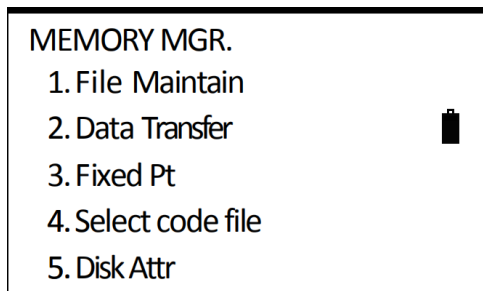

- 2) Press [1] (File Maintain) to display different types of files. Press [1] to [4] to select a certain type. e.g.: Press[2] (COORD. FILE).

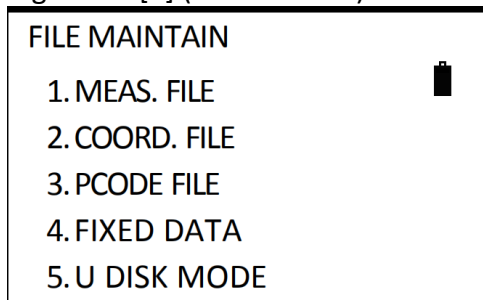

- 3) Press [5] at MEMORY MGR. interface. Choose flash or SD card.

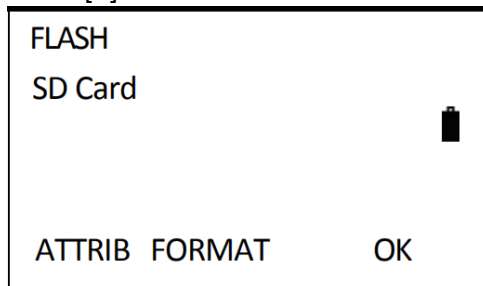

- 4) Press [F1] to check storage internal space, use space, and free space.

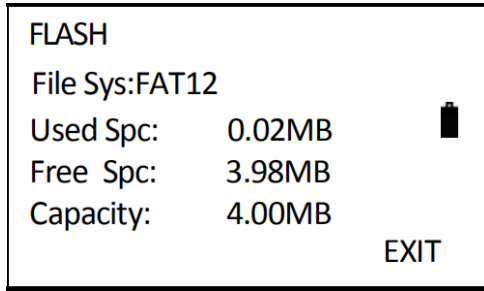

- 5) Press [F2] can format storage memory.

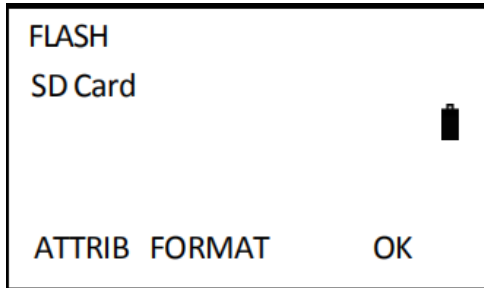

14.1.2. Create a new file

- 1) Press[F1] (NEW) in file list, to create a new project file.

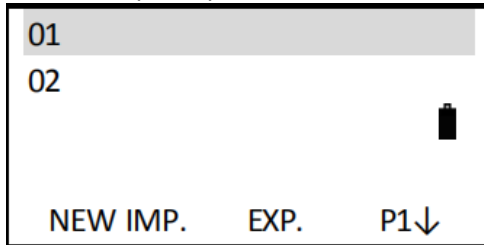

- 2) Press[F1] (ATTR) can check the project status.

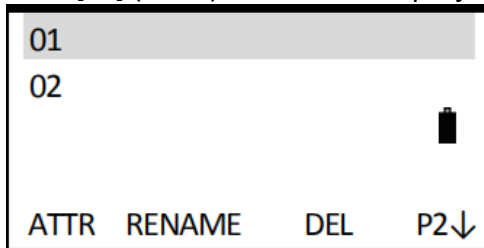

14.1.3. Renaming a file

- 1) In file list, press [▲] or [▼] to select the file to be renamed. Press [▶], [◀] to turn page.

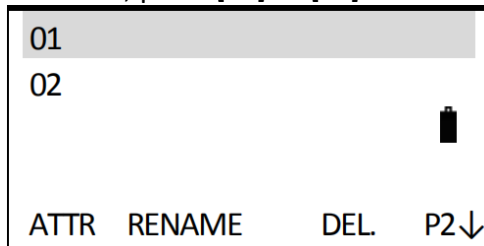

2) Press [F2] (Rename) to rename project.

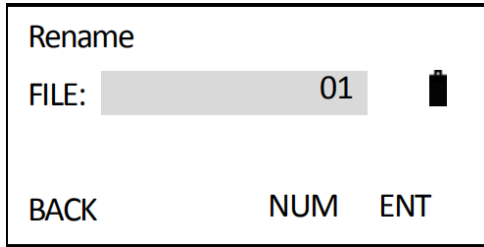

3) Input a new name and press [F4] to confirm.

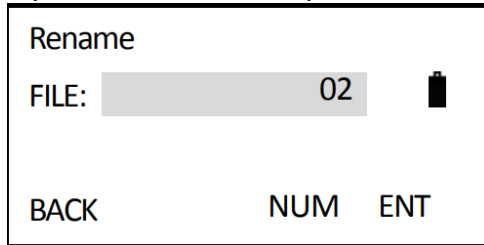

14.1.4. Delete a file

1) Press[F3] to delete the selected project.

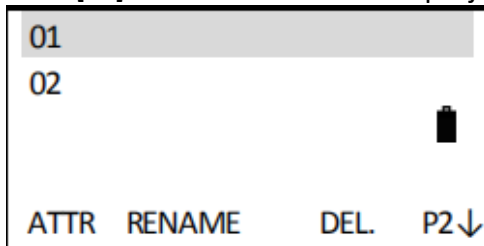

2) Press [F4] to confirm delete the project.

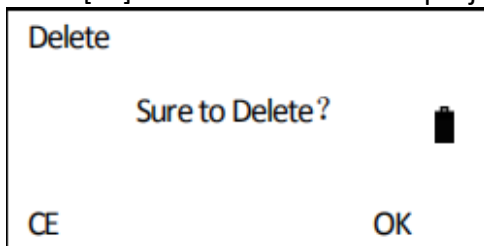

14.2. File output

1) Press [3] (MEMORYMGR.) in MENU1/2.

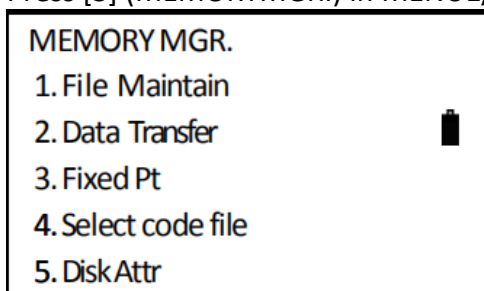

2) Press [1] to choose file export.

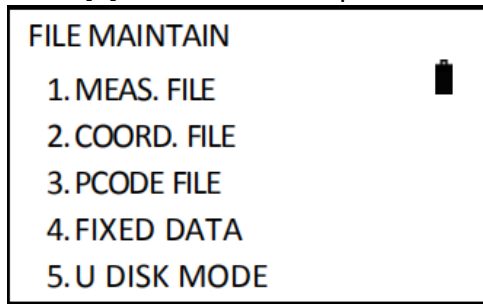

3) Press [F3] to export project. It will create 3 file, TXT, DAT and CSV.

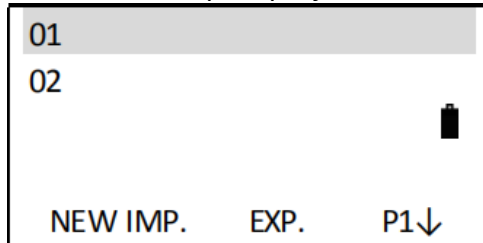

14.3. Data transfer

You can send a data file stored in the SD Card to a computer through data cable.

1) Press [5] to use U Disk Mode. Connect instrument to PC by USB cable.

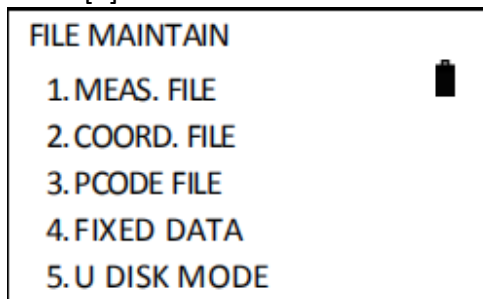

2) The interface will show Connect to PC and you can see SD card memory at PC.

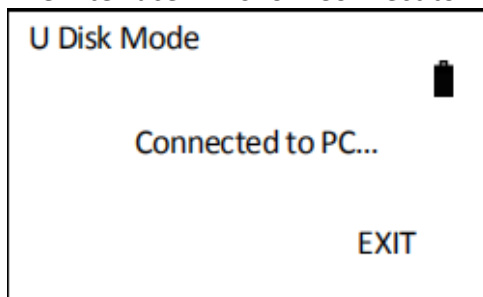

14.4. Load data

Coord. data file and code data can be loaded into instrument memory from computer.

- 1) Press [5] to use U Disk Mode. Connect instrument to PC by USB cable.

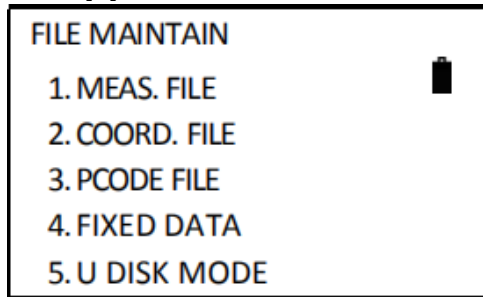

- 2) The interface will show connect to PC and you can see SD card memory at PC.

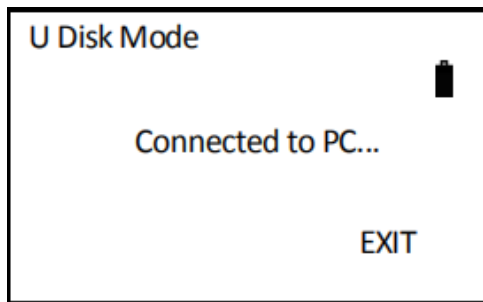

15. Check and adjustment

The instrument has been checked and adjusted strictly in the factory and meet the quality requirement. But the long-distance transportation and the change of the environment will have great influence on internal structure of the instrument. So before using the instrument should be checked and adjusted according to the items of this section.

15.1. Bubble level

Inspection

Refer to section 6.2 “Instrument setup”.

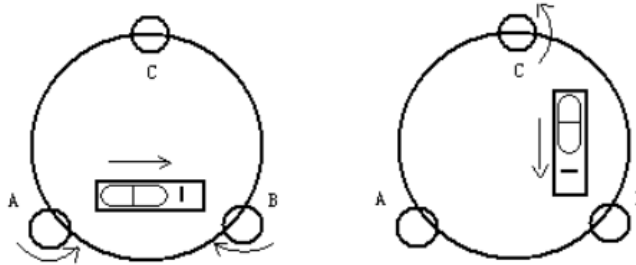

Adjustment

- 1) If the bubble of the plate vial moves from the center, bring it half way back to the center by adjusting the leveling screw, which is parallel to the plate vial. Correct the remaining half by adjusting the screw of plate vial with adjusting pin.
- 2) Confirm whether the bubble does is in the center by rotating the instrument 180°. If not, repeat procedure 1.
- 3) Turn the instrument 90° and adjust the third screw to center the bubble in the vial.
- 4) Repeat inspection and adjustment steps until the bubble remains in center with the vial in any direction.

15.2. Circular level

Inspection

No adjustment is necessary if the bubble of the circular vial is in the center after inspection and adjustment of the plate vial.

Adjustment

If the bubble of the circular vial is not in the center, bring the bubble to the center by using the adjusting pin or hexagon wrench to adjust the bubble adjusting screw. First loosen the screw opposite to the offset side, and then tighten the other adjusting screw on the offset side, bringing the bubble to the center. After the bubble stays in the center, keep the tightness of the three screws in uniform.

15.3. Adjustment of reticle

Inspection

- 1) Sight object A through the telescope and lock the horizontal and vertical clamp screws.
- 2) Move object A to the edge of the field of view with the vertical tangent screw(point A').
- 3) No adjustment is necessary if object A moves along the vertical line of the reticle and point A' still in the vertical line.
- 4) As illustrated, A' offsets from the center and the cross-hair tilts, then need to adjust the reticle.

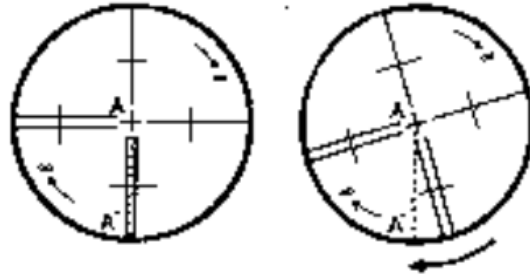

Adjustment

- 1) If the object A does not move along the vertical line, first remove the eyepiece cover to expose the four reticle adjusting screws.
- 2) Loosen the four reticle adjusting screws uniformly with an adjusting pin. Rotate the reticle around the sight line and align the vertical line of the reticle with point A'.
- 3) Tighten the reticle adjusting screws uniformly, repeat the inspection and adjustment to see if the adjustment is correct.
- 4) Replace the eyepiece cover.

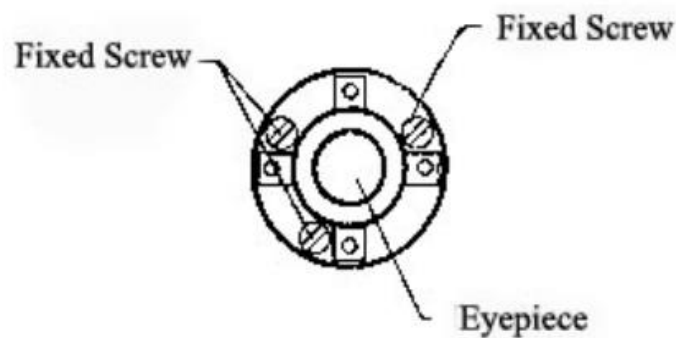

15.4. Perpendicularity of the line of sight to horizontal axis (2C)

Inspection

- 1) Set object A about 100 m away from the instrument and make the target vertical angle in the range of $\pm 3^\circ$, then level and center the instrument and turn on the power.
- 2) Sight object A in left position and read the horizontal angle value (horizontal angle $L = 10^\circ 13' 10''$).
- 3) Loosen the vertical and horizontal clamp screws and rotate the telescope.
- 4) Sight object A in right position and read the horizontal angle value (horizontal angle $L = 190^\circ 13' 40''$).
- 5) $2C = L - (R \pm 180^\circ) = -30'' \geq \pm 20''$, adjustment is necessary.

Adjustment

Electronic adjustment operation steps:

- 1) After leveling the instrument, turn on the instrument, press [MENU], and press [F4] (P↓) to enter page 2 of the menu.

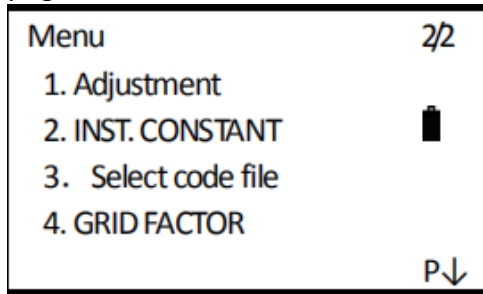

- 2) Press [1] (Adjustment), then select [2] (Collimation)

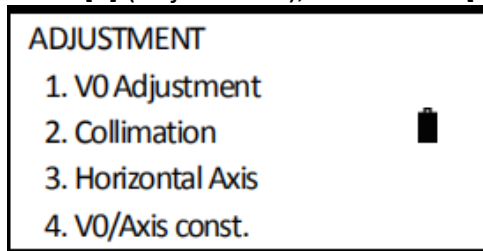

- 3) Collimate target precisely in left position, and press [F4] (OK).

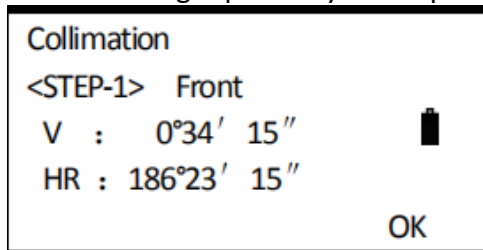

- 4) Rotate the telescope and sight the same target A precisely in the right position. Press [F4].

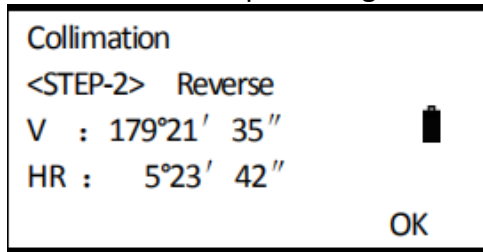

- 5) Setting is finished and the instrument returns to the adjusting menu automatically.

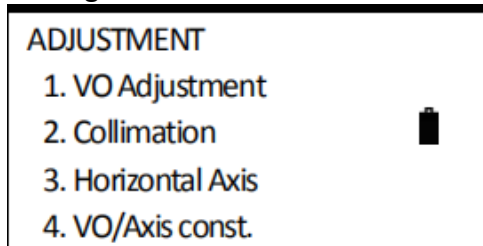

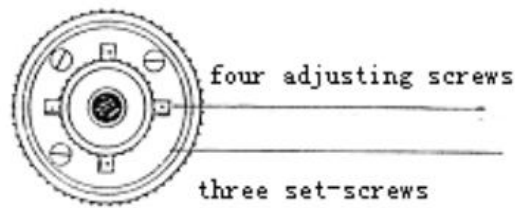

Optical adjustment:

- 1) Use the tangent screw to adjust the horizontal angle reading.
- 2) Take off the cover of the reticle between the eyepiece and focusing screw. Adjust the two adjusting screws by loosening one and tightening the other. Move the reticle to sight object A exactly.
- 3) Repeat inspection and adjustment until $|2C| < 20''$.
- 4) Replace the cover of reticle.



Check the coaxially of sighting axis and emitting photoelectric axis as well as receiving axis after adjusting.

15.5. Vertical index difference compensation

Inspection

- 1) Mount and level the instrument and make the telescope parallel with the line connecting the center of the instrument to any one of the screws. Lock the horizontal clamp screw.
- 2) After turning on the power, zero the vertical index. Lock the vertical clamp screw and the instrument should display the vertical angle value.
- 3) Rotate the vertical clamp screw slowly in either direction about 10 mm in circumference, and the error message "b" will appear. The vertical axis has increased to more than 3' at this time and exceeds the designated compensation range. Rotate the above screw to its original position, and the instrument display screen will show the vertical angle again, meaning that the vertical index difference compensation function is working.

Adjustment

If the compensation function is not working, send the instrument back to the factory for repair.

15.6. Adjustments of vertical index difference (I angle) and vertical angle 0 datum

Inspect the item after finishing the inspection and adjustment of them 15.3 and 15.5.

Inspection

- 1) Power on after leveling the instrument. Sight object A in left position and read the vertical angle value L.
- 2) Rotate the telescope. Sight object B in right position and read the vertical angle value R.
- 3) If the vertical angle is 0° in zenith, $i = (L+R-360°)/2$
If the vertical angle is 0° in horizon. $i = (L+R-180°)/2$ or $i = (L+R-540°)/2$.
- 4) If $|i| \geq 10''$, the vertical angle 0 datum shall be set again.

Adjustment

- 1) After leveling the instrument turn on the instrument, and press [MENU] and [F4] to enter 2/2menu.

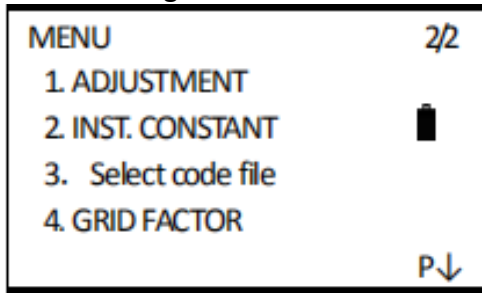

- 2) Press [1] (Adjustment). Select [1]: VO Adjustment.

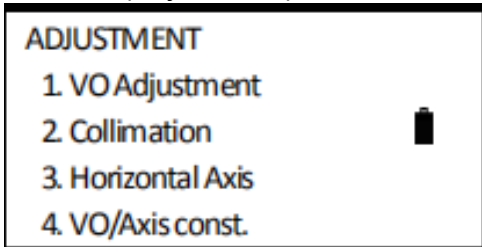

- 3) Aim to target precisely (face left), and press[F4] (OK).

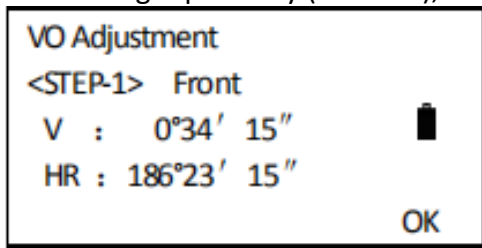

- 4) Rotate the telescope and sight the same target A precisely (face right). Press F4.

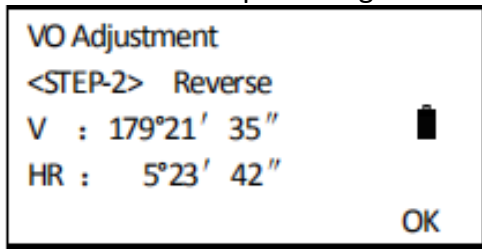

- 5) Setting is finished and the instrument returns to the adjusting menu automatically.

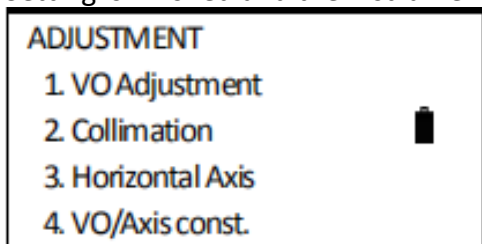

Note

- 1) Repeat the inspection steps to measure the index difference (I angle). If the index difference cannot meet the requirement, you should check whether the three steps of the adjustment are right, the sight is right etc. Then set again according to the requirement.

- 2) If index difference still meets the requirement after the repeated operation, the instrument should be returned to factory for inspection and repair.
- 3) The vertical angles shown in the vertical angle 0 datum are only for reference.

15.7. Transverse axis error compensation adjustment

As the transverse axis error only affects the angle of sight, it can be only confirmed through observing the target of which height is obviously lower or higher than the instrument. To avoid the influence of sight axis, user must have an associated adjustment before adjusting sight axis.

It is unnecessary to collimate the prism or the target plane to decide the transverse axis error. Therefore, user is enabled to launch this adjustment at any time. Select a recognizable point which is rather far away from the instrument, and much higher or lower than the instrument, with an aim to precisely measure the point twice.

- 1) After leveling the instrument, turn on the instrument, and press MENU and [F4] (P↓) to enter 2/2menu.

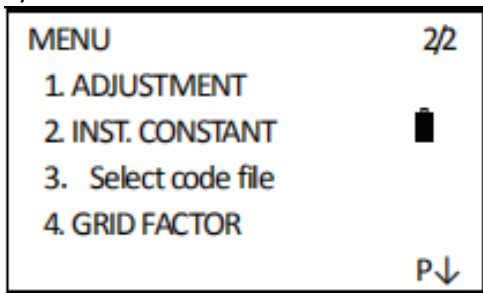

- 2) Press [1] (ADJUSTMENT) and select [3] (Horizontal Axis).

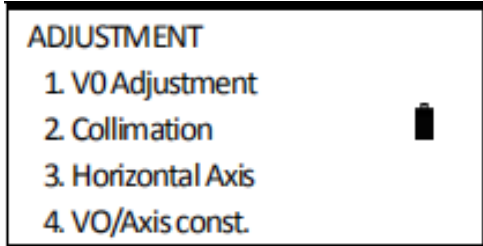

- 3) Aim to the target on face I (left position), press [F4] (OK) 10 times. (The obliquity is among $\pm 10^\circ$ to $\pm 45^\circ$) The screen shows as the right graph.

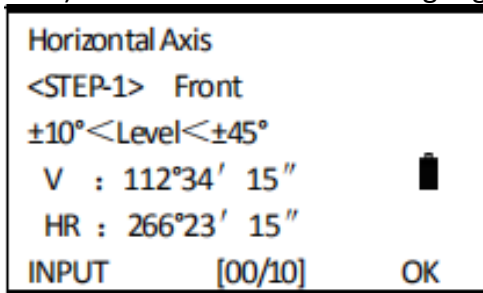

- 4) Rotate the telescope, aim to the same target in face II (right position), press [F4] (OK) 10 times.

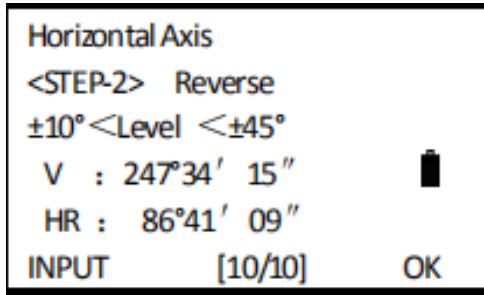

- 5) After setting, the screen returns to ADJUSTMENT menu. After finishing setting, the screen returns to the ADJUSTMENT mode.

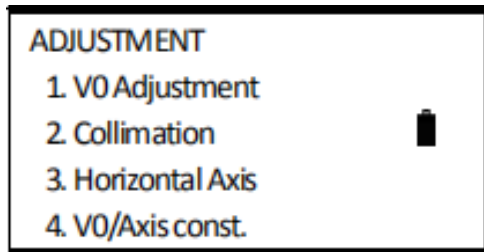

15.8. Optical plummet

Inspection

- 1) Set the instrument on the tripod and place a piece of white paper with two perpendicular lines, then intersect drawn on it directly under the instrument.
- 2) Adjust the focus of the optical plummet and move the paper so that the intersection point of the lines on the paper comes to the center of the field of view.
- 3) Adjust the leveling screws so that the center mark of the optical plummet coincides with the intersection point of the cross on the paper.
- 4) Rotate the instrument around the vertical axis and at every 90° observe whether the center mark position coincides with the intersection point of the cross.
- 5) If the center mark always coincides with intersection point, no adjustment is necessary. Otherwise, the following adjustment is necessary.

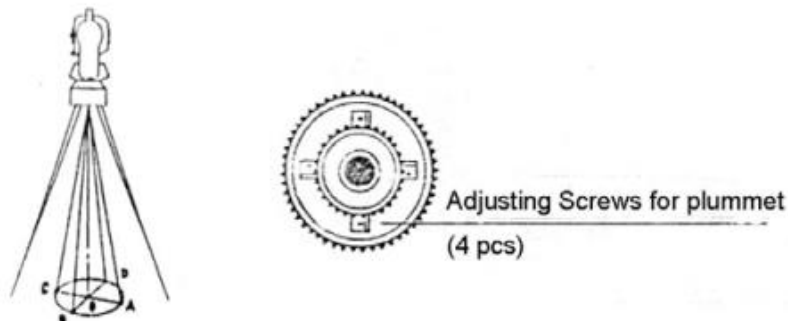

Adjustment

- 1) Take off the protective cover between the optical plummet eyepiece and focusing knob.
- 2) Fix the paper. Rotate the instrument and mark the point of fall of the center of optical plummet on the paper at every 90°. As illustrated: point A, B, C, D.
- 3) Draw lines that attach AC and BD and mark the intersection point of the two lines as O.
- 4) Adjust the four adjusting screws of the optical plummet with an adjusting pin until the center mark coincides with point O.

- 5) Repeat the inspection and adjusting steps to be sure the adjustment is correct.
- 6) Replace the protective cover.

15.9. Instrument constant (K)

Instrument constant has been checked and adjusted in the factor, $K=0$. It changes seldom, and it is suggested to check one or two times every year. The inspection should be made on the base line, also can be made according to the following method.

Inspection

- 1) Mount and level the instrument on point A in a plain place. Use the vertical hair to mark point B and point C on the same line with the distance of 50 m on the same line and set the reflector accurately.
- 2) After setting temperature and air pressure in the instrument, measure the horizontal distance of AB and AC accurately.
- 3) Set the instrument on Point B and center it accurately, measure the Horizontal Distance of BC accurately.
- 4) Then you can get the instrument constant: $K=AC-(AB+BC)$
 K should be closed to 0, if $|K| > 5$ mm, the instrument should be strictly inspected in the standard baseline site and adjusted according the inspection value.

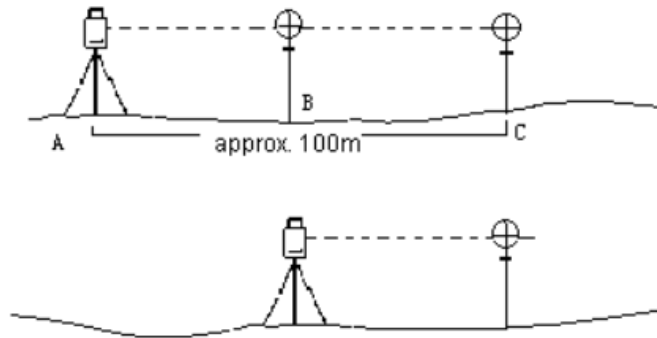

Adjustment

If strict inspection approves that the instrument constant K has changed and is not closed to 0. If the operator wants to adjust, should set stadia constant according the constant K (power on pressing [F1]).

- 1) Set the direction by using the Vertical Hair to make Point A,B,C on the same line strictly. On point there must be fixed and clear centering mark.
- 2) Whether the prism center of point B coincide with the Instrument center the B is the important to inspect the accuracy. So, on point B tripod or tribrach compatible should be used. That will decrease the difference.

15.10. Parallel between line of sight and emitting photoelectric axis

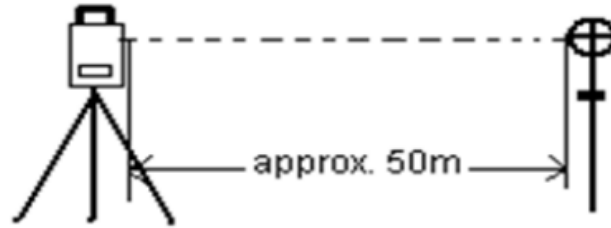

Inspection

- 1) Set the reflector 50m from the instrument.
- 2) Sight the center of the reflector prism with reticle.
- 3) Power on and enter distance measurement mode. Press[MEAS]to measure.
- 4) Rotate the horizontal screw and vertical tangent screw, to do electric collimation and make the light route of EDM unblocked. In the bight zone find the center of emitting photoelectric axis.
- 5) Check whether the center of reticle coincides with the center of emitting photoelectric axis. If so, the instrument is up to grade.

Adjustment

If there is great difference between the center of reticle and the center of emitting photoelectric axis, the instrument need repairing.

15.11. Reflectorless EDM

The red laser beam used for measuring without reflector is arranged coaxially with the line of sight of the telescope and emerges from the objective. If the instrument is well adjusted, the red measuring beam will be coaxial with the visual line of sight. External influences such as shock or large temperature fluctuations can displace the red measuring beam relative to the line of sight.

The direction of the beam should be inspected before precise measurement of distances, because an excessive deviation of the laser beam from the line of sight can result in imprecise distance measurements.



WARNING

Looking straight at the laser beam should be always considered as hazardous.



CAUTION

Do not stare at the beam or point it to the other people. Measuring result might also available even the laser pass through body.

Inspection:

- 1) A target plate is provided. Set it up between five and 20 meters away with the grey reflective side facing the instrument.
- 2) Move the telescope to face II. Switch on the red laser beam by activating the laser-point function. Use the reticle to align the instrument with the center of the target plate, and then inspect the position of the red laser dot on the target plate. The red spot cannot be seen through the telescope, so look at the target plate from just above the telescope or from just to the side of the target plate.
- 3) If the spot illuminates the cross, the achievable adjustment precision has been reached; if it lies outside the limits of the cross, the direction of the beam needs to be adjusted.
- 4) If the spot on the more reflective side of the plate is too bright (dazzling), use the white side instead to carry out the inspection.

15.12. Tribrach leveling screw

If the leveling screw becomes flexible, adjust the two adjusting screw in the leveling screw to tighten the screw appropriately.

15.13. Related parts for reflector

- 1) The tribrach and adapter for reflector. The plate vial and optical plummet in the adapter and tribrach should be checked, refer to chapter 15.1 and 15.7.
- 2) Perpendicularity of the prism pole. As illustrated, mark '+' on point C, place the tine of the prism pole on the point C and do not move during the inspection.
- 3) Place the two feet tine of bipod on point E and F on the cross lines. Adjust the two legs to make the bubble on the prism pole centered.
- 4) Set and level the instrument on point A near the cross. Sight tine of point C with the center of reticle and fix the horizontal clamp screw. Rotate the telescope upward to make D near the horizontal hair.
- 5) Flex the prism pole legs to make the D in the center of reticle. Then both Point C and dare on the central line of reticle.
- 6) Set the instrument on point B on another cross lines. With the same way flexing the Leg f to make point C and dare on the central line of reticle.
- 7) Through the inspection by the instrument on point A and B, prism pole has been perpendicular. If then the bubble offset from the center, adjust the three screws under circular bubble to make the bubble centered.
- 8) Check and adjust again until the bubble will be in the center of the vial from both directions.

Copyright

2018 Shanghai Huace Navigation Technology Ltd. All rights reserved. The CHC and CHC logo are trademarks of Shanghai Huace Navigation Technology Limited. All other trademarks are the property of their respective owners.

Trademarks

All product and brand names mentioned in this publication are trademarks of their respective holders.

CHCNAV - Shanghai Huace Navigation Technology Ltd.

599 Gaojing Road, Building D
Shanghai, 201805, China

Tel: +86 21 542 60 273

Fax: +86 21 649 50 963

Email: sales@chcnav.com | support@chcnav.com

Website: www.chcnav.com