**Optics and optical instruments — Field
procedures for testing geodetic and
surveying instruments —**

**Part 2:
Levels**

*Optique et instruments d'optique — Méthodes d'essai sur site des
instruments géodésiques et d'observation —*

Partie 2: Niveaux



Reference number
ISO 17123-2:2001(E)

PDF disclaimer

This PDF file may contain embedded typefaces. In accordance with Adobe's licensing policy, this file may be printed or viewed but shall not be edited unless the typefaces which are embedded are licensed to and installed on the computer performing the editing. In downloading this file, parties accept therein the responsibility of not infringing Adobe's licensing policy. The ISO Central Secretariat accepts no liability in this area.

Adobe is a trademark of Adobe Systems Incorporated.

Details of the software products used to create this PDF file can be found in the General Info relative to the file; the PDF-creation parameters were optimized for printing. Every care has been taken to ensure that the file is suitable for use by ISO member bodies. In the unlikely event that a problem relating to it is found, please inform the Central Secretariat at the address given below.

Si este documento no tiene el membrete y logo de UNIT en color rojo, es una copia no autorizada



© ISO 2001

All rights reserved. Unless otherwise specified, no part of this publication may be reproduced or utilized in any form or by any means, electronic or mechanical, including photocopying and microfilm, without permission in writing from either ISO at the address below or ISO's member body in the country of the requester.

ISO copyright office
Case postale 56 • CH-1211 Geneva 20
Tel. + 41 22 749 01 11
Fax + 41 22 749 09 47
E-mail copyright@iso.ch
Web www.iso.ch

Printed in Switzerland

Licenciado por el Instituto Uruguayo de Normas Tecnicas a
Otorgado en la fecha de 2023-03-21.
Licencia individual, prohibida su copia y distribucion.

Contents

	Page
1 Scope	1
2 Normative references	1
3 Terms and definitions	2
4 General	2
5 Simplified test procedure	3
6 Full test procedure	5

Annexes

A Example of the simplified test procedure.....	10
A.1 Measurements	10
A.2 Calculation	10
B Example of the full test procedure.....	12
B.1 Measurements	12
B.2 Calculation	12
B.3 Statistical tests	13

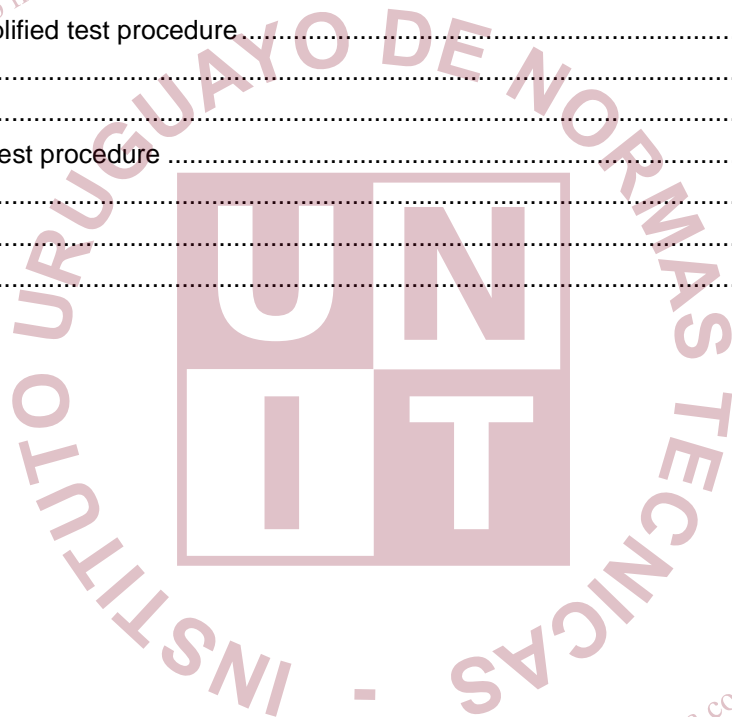

Si este documento no tiene el membrete y logo de UNIT en color rojo, es una copia no autorizada

Foreword

ISO (the International Organization for Standardization) is a worldwide federation of national standards bodies (ISO member bodies). The work of preparing International Standards is normally carried out through ISO technical committees. Each member body interested in a subject for which a technical committee has been established has the right to be represented on that committee. International organizations, governmental and non-governmental, in liaison with ISO, also take part in the work. ISO collaborates closely with the International Electrotechnical Commission (IEC) on all matters of electrotechnical standardization.

International Standards are drafted in accordance with the rules given in the ISO/IEC Directives, Part 3.

Draft International Standards adopted by the technical committees are circulated to the member bodies for voting. Publication as an International Standard requires approval by at least 75 % of the member bodies casting a vote.

Attention is drawn to the possibility that some of the elements of this part of ISO 17123 may be the subject of patent rights. ISO shall not be held responsible for identifying any or all such patent rights.

International Standard ISO 17123-2 was prepared by Technical Committee ISO/TC 172, *Optics and optical instruments*, Subcommittee SC 6, *Geodetic and surveying instruments*.

This first edition of ISO 17123-2 cancels and replaces ISO 8322-3:1989 and ISO 12857-1:1997, which have been technically revised.

ISO 17123 consists of the following parts, under the general title *Optics and optical instruments — Field procedures for testing geodetic and surveying instruments*:

- Part 1: Theory
- Part 2: Levels
- Part 3: Theodolites
- Part 4: Electro-optical distance meters (EDM instruments)
- Part 5: Electronic tacheometers
- Part 6: Rotating lasers
- Part 7: Optical plumbing instruments

Annexes A and B of this part of ISO 17123 are for information only.

Optics and optical instruments — Field procedures for testing geodetic and surveying instruments —

Part 2: Levels

1 Scope

This part of ISO 17123 specifies field procedures to be adopted when determining and evaluating the precision of levels (spirit levels, compensator levels, digital levels) and their ancillary equipment when used in building and surveying measurements. Primarily, these tests are intended to be field verifications of the suitability of a particular instrument for the immediate task at hand and to satisfy the requirements of other standards. They are not proposed as tests for acceptance or performance evaluations that are more comprehensive in nature.

This International Standard can be thought of as one of the first steps in the process of evaluating the uncertainty of a measurement (more specifically a measurand). The uncertainty of a result of a measurement is dependent on a number of factors. These include among others: repeatability, reproducibility (between day repeatability) and a thorough assessment of all possible error sources, as prescribed by the ISO Guide to the expression of uncertainty in measurement (GUM).

These field procedures have been developed specifically for *in situ* applications without the need for special ancillary equipment and are purposely designed to minimize atmospheric influences.

2 Normative references

The following normative documents contain provisions which, through reference in this text, constitute provisions of this part of ISO 17123. For dated references, subsequent amendments to, or revisions of, any of these publications do not apply. However, parties to agreements based on this part of ISO 17123 are encouraged to investigate the possibility of applying the most recent editions of the normative documents indicated below. For undated references, the latest edition of the normative document referred to applies. Members of ISO and IEC maintain registers of currently valid International Standards.

ISO 3534-1, *Statistics — Vocabulary and symbols — Part 1: Probability and general statistical terms*

ISO 4463-1, *Measurement methods for building — Setting-out and measurement — Part 1: Planning and organization, measuring procedures, acceptance criteria*

ISO 7077, *Measuring methods for building — General principles and procedures for the verification of dimensional compliance*

ISO 7078, *Building construction — Procedures for setting out, measurement and surveying — Vocabulary and guidance notes*

ISO 9849, *Optics and optical instruments — Geodetic and surveying instruments — Vocabulary*

ISO 17123-1, *Optics and optical instruments — Field procedures for testing geodetic and surveying instruments — Part 1: Theory*

GUM, *Guide to the expression of uncertainty in measurement*

VIM, *International vocabulary of basic and general terms in metrology*

3 Terms and definitions

For the purposes of this part of ISO 17123, the terms and definitions given in ISO 3534-1, ISO 4463-1, ISO 7077, ISO 7078, ISO 9849, ISO 17123-1, GUM and VIM apply.

4 General

4.1 Requirements

Before commencing surveying, it is important that the operator investigates that the precision in use of the measuring equipment is appropriate to the intended measuring task.

The level and its ancillary equipment shall be in known and acceptable states of permanent adjustment according to the methods specified in the manufacturer's handbook, and used with tripods and levelling staffs as recommended by the manufacturer.

The results of these tests are influenced by meteorological conditions, especially by the gradient of temperature. An overcast sky and low wind speed guarantee the most favourable weather conditions. The particular conditions to be taken into account may vary depending on where the tasks are to be undertaken. Note should also be taken of the actual weather conditions at the time of measurement and the type of surface above which the measurements are made. The conditions chosen for the tests should match those expected when the intended measuring task is actually carried out (see ISO 7077 and ISO 7078).

Tests performed in laboratories would provide results which are almost unaffected by atmospheric influences, but the costs for such tests are very high, and therefore they are not practicable for most users. In addition, laboratory tests yield precisions much higher than those that can be obtained under field conditions.

This part of ISO 17123 describes two different field procedures as given in clauses 5 and 6. The operator shall choose the procedure which is most relevant to the project's particular requirements.

4.2 Procedure 1: Simplified test procedure

The simplified test procedure provides an estimate as to whether the precision of a given levelling equipment is within the specified permitted deviation, according to ISO 4463-1.

This test procedure is normally intended for checking the precision of an optical level to be used for area levelling applications, for tasks where measurements with unequal site lengths are common practice, e.g. building construction sites.

This simplified test procedure is based on a limited number of measurements. Therefore, a significant standard deviation cannot be obtained. If a more precise assessment of the level under field conditions is required it is recommended to adopt the more rigorous full test procedure as given in clause 6.

The procedure relies on determining a height difference between two points, approximately 60 m apart, which is accepted as a true value. The difference between the measured height difference over unequal sight lengths and the value accepted as true between the same two measuring points obtained from equal sight lengths indicates whether the level meets the specified permitted deviation (according to ISO 4463-1) for the intended measuring task.

4.3 Procedure 2: Full test procedure

The full test procedure shall be adopted to determine the best achievable measure of precision of a particular level and its ancillary equipment under field conditions and requires adoption of equal sight lengths (maximum variation 10 %). It is normally intended for field trials of levels to be used for more precise levelling, linear applications and other major surveys, e.g. civil engineering.

The recommended sight lengths are 30 m. Sight lengths greater than 30 m may be adopted for this precision in use test where required by the project specification, or to determine the range of the measure of precision of a level at respective distances.

The full test procedure is based only on equal sight lengths. A displacement of the collimation axis of the level cannot be detected by this procedure. But this collimation error has no influence either on the experimental standard deviation or on the difference in the zero-point offsets of the levelling staffs using equal sight lengths. In order to determine the collimation error, the instrument must be checked before commencing levelling in accordance with the manufacturer's handbook.

The test procedure given in clause 6 of this part of ISO 17123 is intended for determining the measure of precision in use of a particular level. This measure of precision in use is expressed in terms of the experimental standard deviation of a 1-km double-run levelling:

$s_{\text{ISO-LEV}}$

Further, this procedure may be used to determine:

- the measure of precision in use of levels by a single survey team with a single instrument and its ancillary equipment at a given time;
- the measure of precision in use of a single instrument over time;
- the measure of precision in use of each of several levels in order to enable a comparison of their respective achievable precisions to be obtained under similar field conditions.

Statistical tests should be applied to determine whether the experimental standard deviation, s , obtained belongs to the population of the instrumentation's theoretical standard deviation, σ , whether two tested samples belong to the same population and whether the difference, δ , of the zero-points of the levelling staffs is equal to zero (see clause 6.4 of this part of ISO 17123).

5 Simplified test procedure

5.1 Configuration of the test line

To keep the influence of refraction as small as possible, a reasonably horizontal test area shall be chosen. Two levelling points, A and B, shall be set up approximately $\Delta = 60$ m apart (or covering the range applicable to the project). To ensure reliable results, the levelling staffs shall be set up in stable positions, reliably fixed during the test measurements, including repeat measurements.

5.2 Measurements

Before commencing the measurements, allow the instrument to acclimatize to the ambient temperature. The time required is about two minutes per degree Celsius temperature difference. Further, the user shall check the collimation error before the test.

Two sets of readings shall be carried out. For the first set, the level shall be set up approximately equidistant between the levelling points A and B ($\Delta/2 = 30$ m). This configuration minimizes the influence of the refraction and the displacement of the collimation axis (see Figure 1). A set of ten measurements shall be performed with each measurement consisting of one backward reading, $x_{A,j}$, to the levelling staff at point A and one forward reading, $x_{B,j}$, to the levelling staff at point B, ($j = 1, \dots, 10$). Between each pair of readings the instrument has to be lifted, and placed at a slightly different position. After five measurements ($x_{A,1}, x_{B,1}, \dots, x_{A,5}, x_{B,5}$), the backward and forward readings shall be reversed for another five measurements ($x_{B,6}, x_{A,6}, \dots, x_{B,10}, x_{A,10}$).

For the second set of readings, the level shall be set up approximately $\Delta/6 = 10$ m from point A and $5\Delta/6 = 50$ m from point B (see Figure 2). Then, another ten measurements ($x_{A,11}, x_{B,11}, \dots, x_{A,15}, x_{B,15}; x_{B,16}, x_{A,16}, \dots, x_{B,20}, x_{A,20}$) shall be taken in the same manner as defined for the first set of measurements ($j = 11, \dots, 20$).

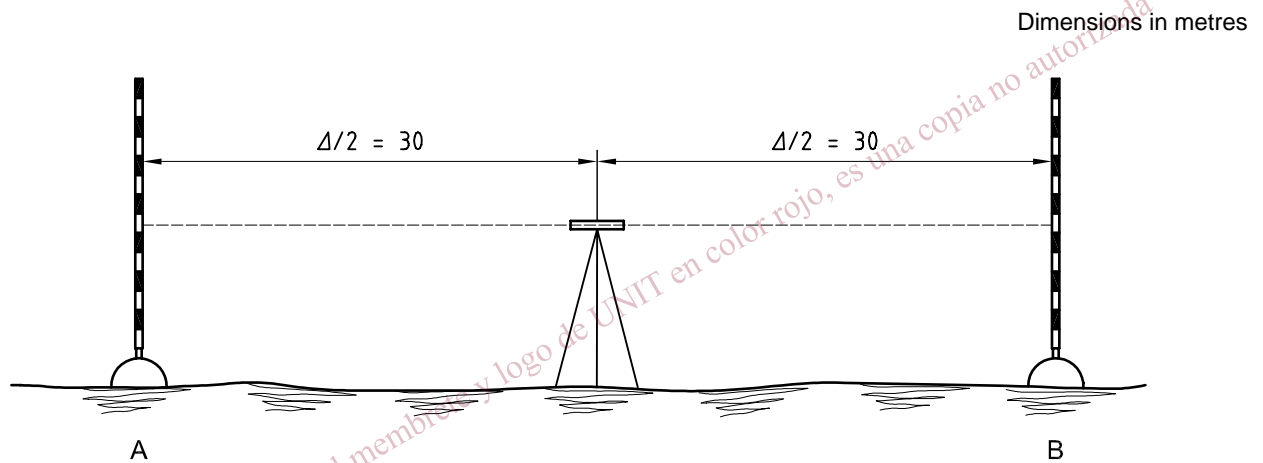

Figure 1 — First configuration of the test line for the simplified test procedure

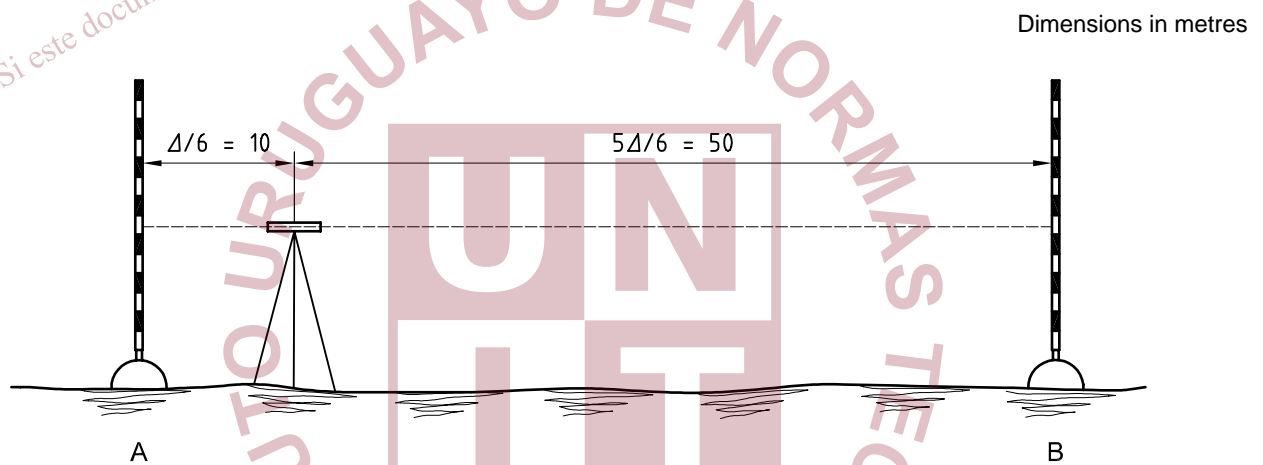

Figure 2 — Second configuration of the test line for the simplified test procedure

5.3 Calculation

$$d_j = x_{A,j} - x_{B,j}; \quad j = 1, \dots, 20 \quad (1)$$

where d_j is the difference between the backward reading, $x_{A,j}$, and the forward reading, $x_{B,j}$.

$$\bar{d}_1 = \frac{\sum_{j=1}^{10} d_j}{10} \quad (2)$$

where \bar{d}_1 is the arithmetic mean of the height differences, d_j , of the first set of measurements.

The value of \bar{d}_1 is considered to represent the true height difference between the levelling points A and B.

$$r_j = \bar{d}_1 - d_j; \quad j = 1, \dots, 10 \quad (3)$$

where r_j is the residual of the corresponding measured height difference, d_j , of the first set of measurements between the two levelling points A and B.

As an arithmetic check, the sum of the residuals of set 1 shall be zero (except for rounding errors):

$$\sum_{j=1}^{10} r_j = 0 \quad (4)$$

$$s = \sqrt{\frac{\sum_{j=1}^{10} r_j^2}{\nu}} \quad (5)$$

where

$\sum_{j=1}^{10} r_j^2$ is the sum of squares of the residuals r_j of set 1;

$\nu = 10 - 1 = 9$ is the corresponding number of degrees of freedom;

s is the experimental standard deviation of a height difference, d_j , derived from the measurements of set 1.

$$\bar{d}_2 = \frac{\sum_{j=11}^{20} d_j}{10} \quad (6)$$

where \bar{d}_2 is the arithmetic mean of the height differences, d_j , of the second set of measurements.

The difference $\bar{d}_1 - \bar{d}_2$ has to be within the specified permitted deviation $\pm p$ (in accordance with ISO 4463-1) for the intended measuring task. If p is not given, the difference shall be $|\bar{d}_1 - \bar{d}_2| < 2,5 \times s$, where s is the experimental standard deviation calculated according to equation (5).

If the difference $|\bar{d}_1 - \bar{d}_2|$ is too large, this indicates an excessive uncertainty of the measurement across the long distance (50 m), resulting from reading error, refraction and displacement of the collimation axis.

In this case:

- check the collimation error according to the user manual;
- reduce the maximum distance.

6 Full test procedure

6.1 Configuration of the test line

To keep the influence of refraction as small as possible, a reasonably horizontal test area should be chosen. The ground should be compact and the surface should be uniform, roads covered with asphalt or concrete should be avoided. If there is direct sunlight, the instrument shall be shaded, for example by an umbrella.

Two levelling points, A and B, shall be set up approximately $\Delta = 60$ m apart. To ensure reliable results, the levelling staffs shall be set up in stable positions, reliably fixed during the test measurements, including repeat measurements.

The level shall be set up approximately equidistant between the levelling points, A and B ($\Delta/2 = 30 \text{ m} \pm 3 \text{ m}$), to reduce the influence of refraction and of the displacement of the collimation axis (see Figure 3).

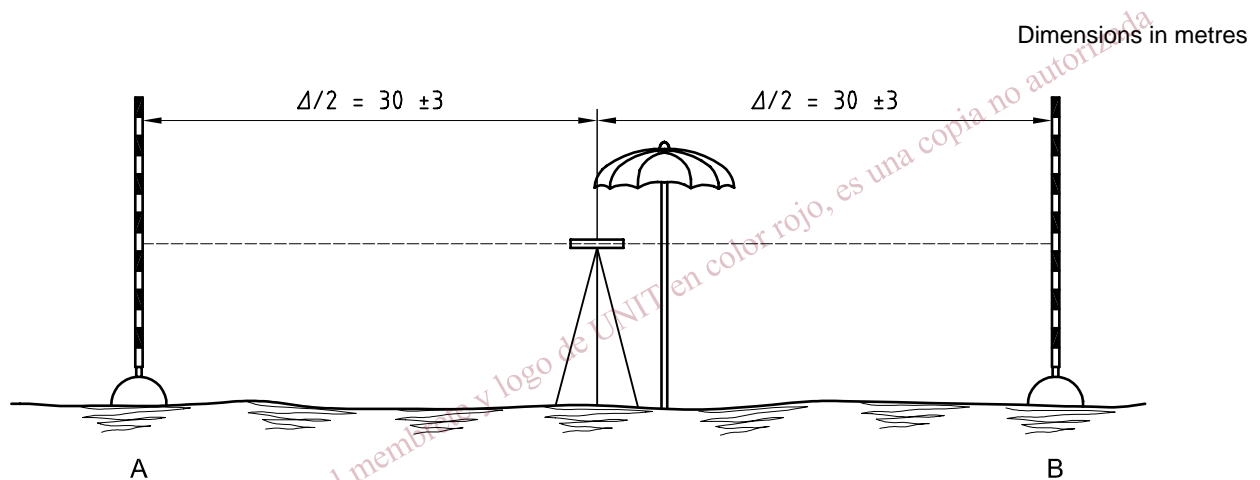

Figure 3 — Configuration of the test line for the full test procedure

6.2 Measurements

Before commencing the measurements, allow the instrument to acclimatize to the ambient temperature. The time required is about two minutes per degree Celsius temperature difference. Further, the user shall check the collimation error before the test.

Two sets of readings shall be carried out. The first set shall consist of twenty pairs of readings with each measurement comprising one backward reading, $x_{A,j}$, to the levelling staff at point A and one forward reading, $x_{B,j}$, to the levelling staff at point B ($j = 1, \dots, 20$). Between each pair of readings, the instrument has to be lifted and placed at a slightly different position. After ten measurements ($x_{A,1}, x_{B,1}, \dots, x_{A,10}, x_{B,10}$), the backward and forward readings shall be reversed for another ten measurements ($x_{B,11}, x_{A,11}, \dots, x_{B,20}, x_{A,20}$).

Then, the two levelling staffs at the points A and B shall be interchanged and the procedure shall be repeated another twenty times ($x_{A,21}, x_{B,21}, \dots, x_{A,30}, x_{B,30}; x_{B,31}, x_{A,31}, \dots, x_{B,40}, x_{A,40}$) in the same manner as described for the first set of measurements.

6.3 Calculation

$$d_j = x_{A,j} - x_{B,j}; \quad j = 1, \dots, 40 \tag{7}$$

where d_j is the difference between the backward reading, $x_{A,j}$, and the forward reading, $x_{B,j}$.

$$\bar{d}_1 = \frac{\sum_{j=1}^{20} d_j}{20} \tag{8}$$

where \bar{d}_1 is the arithmetic mean of the height differences, d_j , of the first set of measurements.

$$\bar{d}_2 = \frac{\sum_{j=21}^{40} d_j}{20} \tag{9}$$

where \bar{d}_2 is the arithmetic mean of the height differences, d_j , of the second set of measurements.

The difference:

$$\delta = \bar{d}_1 - \bar{d}_2 \tag{10}$$

has no influence on the experimental standard deviation, but it is an indicator of a difference in the zero-point offsets of the two levelling staffs. For adequate interpretation refer to subclause 6.4.4.

The residuals are calculated as follows:

$$r_j = \bar{d}_1 - d_j; \quad j = 1, \dots, 20 \quad (11)$$

$$r_j = \bar{d}_2 - d_j; \quad j = 21, \dots, 40 \quad (12)$$

where r_j is the residual of the corresponding measured height difference, d_j , between the two levelling points A and B.

As arithmetic checks, the sums of the residuals of set 1 and set 2 shall be zero (except for rounding errors):

$$\sum_{j=1}^{20} r_j = 0 \quad (13)$$

$$\sum_{j=21}^{40} r_j = 0 \quad (14)$$

$$\sum_{j=1}^{40} r_j^2 = \sum_{j=1}^{20} r_j^2 + \sum_{j=21}^{40} r_j^2 \quad (15)$$

where $\sum_{j=1}^{40} r_j^2$ is the sum of the squares of all residuals r_j .

$$\nu = 2 \times (20 - 1) = 38 \quad (16)$$

where ν is the number of degrees of freedom.

The experimental standard deviation, s , is valid for a height difference at a distance of 60 m:

$$s = \sqrt{\frac{\sum_{j=1}^{40} r_j^2}{\nu}} = \sqrt{\frac{\sum_{j=1}^{40} r_j^2}{38}} \quad (17)$$

$$s_{\text{ISO-LEV}} = \frac{s}{\sqrt{2}} \times \sqrt{\frac{1\,000\text{ m}}{60\text{ m}}} = s \times 2,89 \quad (18)$$

where $s_{\text{ISO-LEV}}$ is the experimental standard deviation for 1 km double-run levelling.

6.4 Statistical tests

6.4.1 General

Statistical tests are recommended for the full test procedure only.

For the interpretation of the results, statistical tests shall be carried out using:

- the experimental standard deviation, s , of a height difference measured on the test line, and
- the difference, δ , in the zero-point offsets of the two levelling staffs and its experimental standard deviation, s_δ

in order to answer the following questions (see Table 1):

- a) Is the calculated experimental standard deviation, s , smaller than a corresponding value, σ , stated by the manufacturer or smaller than another predetermined value, σ ?
- b) Do two experimental standard deviations, s and \tilde{s} , as determined from two different samples of measurements, belong to the same population, assuming that both samples have the same number of degrees of freedom, ν ?

The experimental standard deviations, s and \tilde{s} , may be obtained from:

- two samples of measurements by the same instrument but different observers;
- two samples of measurements by the same instrument at different times;
- two samples of measurements by different instruments.

- c) Is the difference δ in the zero-point offsets of the two levelling staffs equal to zero?

For the following tests, a confidence level of $1 - \alpha = 0,95$ and, according to the design of the measurements, a number of degrees of freedom of $\nu = 38$ are assumed.

Table 1 — Statistical tests

Question	Null hypothesis	Alternative hypothesis
a)	$s \leq \sigma$	$s > \sigma$
b)	$\sigma = \tilde{\sigma}$	$\sigma \neq \tilde{\sigma}$
c)	$\delta = 0$	$\delta \neq 0$

6.4.2 Question a)

The null hypothesis stating that the experimental standard deviation, s , is smaller than or equal to a theoretical or a predetermined value, σ , is not rejected if the following condition is fulfilled:

$$s \leq \sigma \times \sqrt{\frac{\chi^2_{1-\alpha}(\nu)}{\nu}} \tag{19}$$

$$s \leq \sigma \times \sqrt{\frac{\chi^2_{0,95}(38)}{38}} \tag{20}$$

$$\chi^2_{0,95}(38) = 53,38 \tag{21}$$

$$s \leq \sigma \times \sqrt{\frac{53,38}{38}} \tag{22}$$

$$s \leq \sigma \times 1,19 \tag{23}$$

Otherwise, the null hypothesis is rejected.

6.4.3 Question b)

In the case of two different samples, a test indicates whether the experimental standard deviations, s and \tilde{s} , belong to the same population. The corresponding null hypothesis, $\sigma = \tilde{\sigma}$, is not rejected if the following condition is fulfilled:

$$\frac{1}{F_{1-\alpha/2}(\nu, \nu)} \leq \frac{s^2}{\tilde{s}^2} \leq F_{1-\alpha/2}(\nu, \nu) \tag{24}$$

$$\frac{1}{F_{0,975}(38,38)} \leq \frac{s^2}{\bar{s}^2} \leq F_{0,975}(38,38) \quad (25)$$

$$F_{0,975}(38,38) = 1,91 \quad (26)$$

$$0,52 \leq \frac{s^2}{\bar{s}^2} \leq 1,91 \quad (27)$$

Otherwise, the null hypothesis is rejected.

6.4.4 Question c)

The hypothesis of equality of the mean values \bar{d}_1 and \bar{d}_2 (null hypothesis of δ) is not rejected if the following condition is fulfilled:

$$|\delta| \leq s_\delta \times t_{1-\alpha/2}(\nu) \quad (28)$$

$$|\delta| \leq s_\delta \times t_{0,975}(38) \quad (29)$$

$$s_\delta = \frac{s}{\sqrt{10}} \quad (30)$$

$$t_{0,975}(38) = 2,02 \quad (31)$$

$$|\delta| \leq \frac{s}{\sqrt{10}} \times 2,02 \quad (32)$$

$$\leq s \times 0,64$$

Otherwise, the null hypothesis is rejected.

The number of degrees of freedom and, thus, the corresponding test values $\chi^2_{1-\alpha}(\nu)$, $F_{1-\alpha/2}(\nu, \nu)$ and $t_{1-\alpha/2}(\nu)$ (taken from reference books on statistics) change if a different number of measurements is analysed.

Annex A
(informative)

Example of the simplified test procedure

A.1 Measurements

Table A.1 contains, in columns 1 to 3 and 7 to 9, the twenty forward and backward readings (measured values $x_{A,j}$ and $x_{B,j}$).

Observer: S. Miller
 Weather: cloudy, + 10 °C
 Instrument type and number: NN xxx 630401
 Date: 1999-04-15

Table A.1 — Measurements and residuals

1	2	3	4	5	6	7	8	9	10
j	$x_{A,j}$ mm	$x_{B,j}$ mm	d_j mm	r_j mm	r_j^2 mm ²	j	$x_{A,j}$ mm	$x_{B,j}$ mm	d_j mm
1	1 048	1 232	-184	0,6	0,36	11	1 115	1 300	-185
2	1 017	1 200	-183	-0,4	0,16	12	1 123	1 307	-184
3	1 061	1 245	-184	0,6	0,36	13	1 145	1 328	-183
4	1 048	1 231	-183	-0,4	0,16	14	1 167	1 351	-184
5	1 012	1 195	-184	-0,4	0,16	15	1 155	1 341	-186
6	1 051	1 235	-184	0,6	0,36	16	1 137	1 322	-185
7	1 054	1 238	-184	0,6	0,36	17	1 119	1 304	-185
8	1 038	1 221	-183	-0,4	0,16	18	1 127	1 312	-185
9	1 036	1 219	-183	-0,4	0,16	19	1 140	1 324	-184
10	1 052	1 235	-183	-0,4	0,16	20	1 144	1 328	-184
Σ	10 417	12 251	-1 834	0,0	2,40	Σ	11 372	13 217	-1 845

A.2 Calculation

First, the measured height differences, d_1, \dots, d_{20} , are calculated according to equation (1) (see columns 4 and 10 in Table A.1).

Using the means of the sums of the values in the columns 4 and 10 in Table A.1, equations (2) and (6) result in the following:

$$\bar{d}_1 = \frac{\sum_{j=1}^{10} d_j}{10} = \frac{-1\,834\text{ mm}}{10} = -183,4\text{ mm}$$

$$\bar{d}_2 = \frac{\sum_{j=11}^{20} d_j}{10} = \frac{-1\,845\text{ mm}}{10} = -184,5\text{ mm}$$

The difference equals

$$\bar{d}_1 - \bar{d}_2 = 1,1 \text{ mm}$$

The residuals, r_j , of the height differences, d_j , of the first set of measurements are calculated according to equation (3) (see column 5 in Table A.1).

By means of the square sums of the residuals of set 1 (see the last line of column 6 in Table A.1), the experimental standard deviation, s , is calculated according to equation (5):

$$s = \sqrt{\frac{\sum_{j=1}^{10} r_j^2}{\nu}} = \sqrt{\frac{2,40}{9}} = 0,5 \text{ mm}$$

The following arithmetic checks shall be fulfilled:

— the difference of the sums in columns 2 and 3 shall be equal to the sum of column 4:

$$-12\,251 + 10\,417 = -1\,834$$

— the difference of the sums in columns 8 and 9 shall be equal to the sum of column 10:

$$-13\,217 + 11\,372 = -1\,845$$

— the sum of the residuals in column 5 shall be equal to zero (except for rounding errors).

The difference $\bar{d}_1 - \bar{d}_2 = -1,1 \text{ mm}$ is smaller than $2,5 \times s = 2,5 \times 0,5 = 1,25 \text{ mm}$. This result shows that there is no indication of an excessive uncertainty of the measurement, resulting from reading errors, refraction and displacement of the collimation axis.

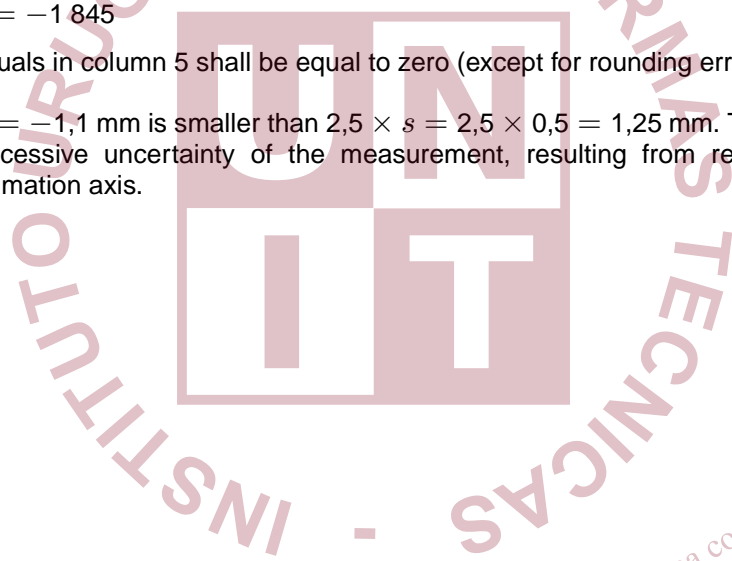

Si este documento no tiene el membrete y logo de UNIT en color rojo, es una copia no autorizada

Annex B
(informative)

Example of the full test procedure

B.1 Measurements

Table B.1 contains, in columns 1 to 3 and 7 to 9, the forty forward and backward readings (measured values $x_{A,j}$, and $x_{B,j}$).

Observer: S. Miller
 Weather: cloudy, + 10 °C
 Instrument type and number: NN xxx 630401
 Date: 1999-04-15

Table B.1 — Measurements and residuals

1	2	3	4	5	6	7	8	9	10	11	12
j	$x_{A,j}$	$x_{B,j}$	d_j	r_j	r_j^2	j	$x_{A,j}$	$x_{B,j}$	d_j	r_j	r_j^2
	mm	mm	mm	mm	mm ²		mm	mm	mm	mm	mm ²
1	1 048	1 232	-184	0,7	0,49	21	1 005	1 188	-183	-0,1	0,01
2	1 017	1 200	-183	-0,3	0,09	22	1 013	1 196	-183	-0,1	0,01
3	1 061	1 245	-184	0,7	0,49	23	1 035	1 218	-183	-0,1	0,01
4	1 048	1 231	-183	-0,3	0,09	24	1 057	1 241	-184	0,9	0,81
5	1 012	1 195	-183	-0,3	0,09	25	1 045	1 228	-183	-0,1	0,01
6	1 051	1 235	-184	0,7	0,49	26	1 027	1 211	-184	0,9	0,81
7	1 054	1 238	-184	0,7	0,49	27	1 009	1 192	-183	-0,1	0,01
8	1 038	1 221	-183	-0,3	0,09	28	1 017	1 199	-182	-1,1	1,21
9	1 036	1 219	-183	-0,3	0,09	29	1 030	1 213	-183	-0,1	0,01
10	1 052	1 235	-183	-0,3	0,09	30	1 034	1 216	-182	-1,1	1,21
11	1 031	1 214	-183	-0,3	0,09	31	1 043	1 226	-183	-0,1	0,01
12	1 028	1 212	-184	0,7	0,49	32	1 037	1 220	-183	-0,1	0,01
13	1 039	1 222	-183	-0,3	0,09	33	1 025	1 208	-183	-0,1	0,01
14	1 040	1 223	-183	-0,3	0,09	34	1 050	1 232	-182	-1,1	1,21
15	1 031	1 213	-182	-1,3	1,69	35	1 039	1 222	-183	-0,1	0,01
16	1 050	1 233	-183	-0,3	0,09	36	1 024	1 207	-183	-0,1	0,01
17	1 056	1 239	-183	-0,3	0,09	37	1 030	1 214	-184	0,9	0,81
18	1 028	1 212	-184	0,7	0,49	38	1 041	1 225	-184	0,9	0,81
19	1 034	1 218	-184	0,7	0,49	39	1 012	1 196	-184	0,9	0,81
20	1 049	1 232	-183	-0,3	0,09	40	1 019	1 202	-183	-0,1	0,01
Σ	20 803	24 469	-3 666	0,0	6,20	Σ	20 592	24 254	-3 662	0,0	7,80

B.2 Calculation

First, the measured height differences, $d_1 \dots, d_{40}$, are calculated according to equation (7) (see columns 4 and 10 in Table B.1).

Using the means of the sums of the values in the columns 4 and 10 in Table B.1, equations (8) and (9) result in the following:

$$\bar{d}_1 = \frac{\sum_{j=1}^{20} d_j}{20} = \frac{-3\,666 \text{ mm}}{20} = -183,3 \text{ mm}$$

$$\bar{d}_2 = \frac{\sum_{j=21}^{40} d_j}{20} = \frac{-3\,662 \text{ mm}}{20} = -183,1 \text{ mm}$$

δ is calculated according to equation (10):

$$\delta = \bar{d}_1 - \bar{d}_2 = -183,3 \text{ mm} - (-183,1 \text{ mm}) = -0,2 \text{ mm}$$

The residuals, r_j , the height differences, d_j , are calculated according to equations (11) and (12) (see columns 5 and 11 in Table B.1).

By means of the square sums of the residuals of set 1 and set 2 (see the last lines of the columns 6 and 12 in Table B.1), the square sum of the residuals, r_j , and the experimental standard deviation, s , of 1-km double-run levelling are calculated according to the equations (15) to (18):

$$\sum_{j=1}^{40} r_j^2 = 6,20 \text{ mm}^2 + 7,80 \text{ mm}^2 = 14,00 \text{ mm}^2$$

$$\nu = 38$$

$$s = \sqrt{\frac{14,00 \text{ mm}^2}{38}} = 0,61 \text{ mm} \approx 0,6 \text{ mm}$$

$$s_{\text{ISO-LEV}} = s \times 2,89 = 0,61 \text{ mm} \times 2,89 = 1,76 \approx 1,8 \text{ mm}$$

The following arithmetic checks shall be fulfilled:

- the difference of the sums in columns 2 and 3 shall be equal to the sum of column 4:
24 469 – 20 803 = 3 666;
- the difference of the sums in columns 8 and 9 shall be equal to the sum of column 10:
24 254 – 20 592 = 3 662;
- the sum of the residuals in column 5 shall be equal to zero (except for rounding errors);
- the sum of the residuals in column 11 shall be equal to zero (except for rounding errors).

B.3 Statistical tests

B.3.1 Statistical test according to question a)

$$\sigma = 1,0 \text{ mm}$$

$$s_{\text{ISO-LEV}} = 1,8 \text{ mm}$$

$$\nu = 38$$

$$1,8 \text{ mm} \leq 1,0 \text{ mm} \times 1,19$$

$$1,8 \text{ mm} \leq 1,2 \text{ mm}$$

Since the above condition is not fulfilled, the null hypothesis stating that the empirically determined standard deviation, $s = 1,8 \text{ mm}$, is smaller than or equal to the manufacturer's value, $\sigma = 1,0 \text{ mm}$, is rejected at the confidence level of 95 %.

B.3.2 Statistical test according to question b)

$$s = 1,8 \text{ mm}$$

$$\tilde{s} = 2,6 \text{ mm}$$

$$\nu = 38$$

$$0,52 \leq \frac{3,24 \text{ mm}^2}{6,76 \text{ mm}^2} \leq 1,91$$

$$0,52 \leq 0,48 \leq 1,91$$

Since the above condition is not fulfilled, the null hypothesis stating that the experimental standard deviations $s = 1,8 \text{ mm}$ and $\tilde{s} = 2,6 \text{ mm}$ belong to the same population is rejected at the confidence level of 95 %.

B.3.3 Statistical test according to question c)

$$s = 0,6 \text{ mm}$$

$$\nu = 38$$

$$\delta = 0,2 \text{ mm}$$

$$s_\delta = 0,2 \text{ mm}$$

$$0,2 \text{ mm} \leq 0,2 \text{ mm} \times 2,0$$

$$\leq 0,4 \text{ mm}$$

Since the above condition is fulfilled, the null hypothesis stating that the zero-point offset of the levelling staffs is equal to zero is not rejected at the confidence level of 95 %.

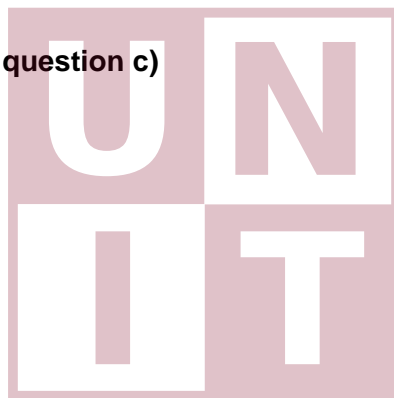

Si este documento no tiene el membrete y logo de UNIT en color rojo, es una copia no autorizada



Si este documento no tiene el membrete y logo de UNIT en color rojo, es una copia no autorizada

Si este documento no tiene el membrete y logo de UNIT en color rojo, es una copia no autorizada



Si este documento no tiene el membrete y logo de UNIT en color rojo, es una copia no autorizada

ICS 17.180.30

Price based on 14 pages