

# How to design reinforced concrete flat slabs using Finite Element Analysis

**O Brooker** BEng, CEng, MICE, MStructE

## FE Analysis

### Advantages

- It assists in the design of slabs with complex geometry where other methods require conservative assumptions to be made.
- It can be used to assess the forces around large openings.
- It can be used to estimate deflections where other methods are time-consuming, particularly for complex geometry. This is provided that the advice on deflection calculations later in this guide is followed.
- It can be used for unusual loading conditions, e.g. transfer slabs.
- The model can be updated should changes occur to the design of the structure.
- Computer processing speeds are increasing; reducing the time for analysis.

### Disadvantages

- The model can take time to set-up, although the latest generation of software has speeded up this process considerably.
- The redistribution of moments is not easily achieved.
- There is a steep learning curve for new users and the modelling assumptions must be understood.
- Human errors can occur when creating the model; these can be difficult to locate during checking.
- Design using FE requires engineering judgement and a feel for the behaviour of concrete.

## Introduction

The relative cost of computer hardware and software has reduced significantly over recent years and many engineers now have access to powerful software such as finite element (FE) analysis packages. However, there is no single source of clear advice on how to correctly analyse and design using this type of software. This guide seeks to introduce FE methods, explain how concrete can be successfully modelled and how to interpret the results. It will also highlight the benefits, some of the common pitfalls and give guidance on best practice.

## What is FE and why use it?

### What is FE analysis?

Finite element analysis is a powerful computer method of analysis that can be used to obtain solutions to a wide range of one- two- and three-dimensional structural problems involving the use of ordinary or partial differential equations. For the majority of structural applications the displacement FE method is used, where displacements are treated as unknown variables to be solved by a series of algebraic equations. Each member within the structure

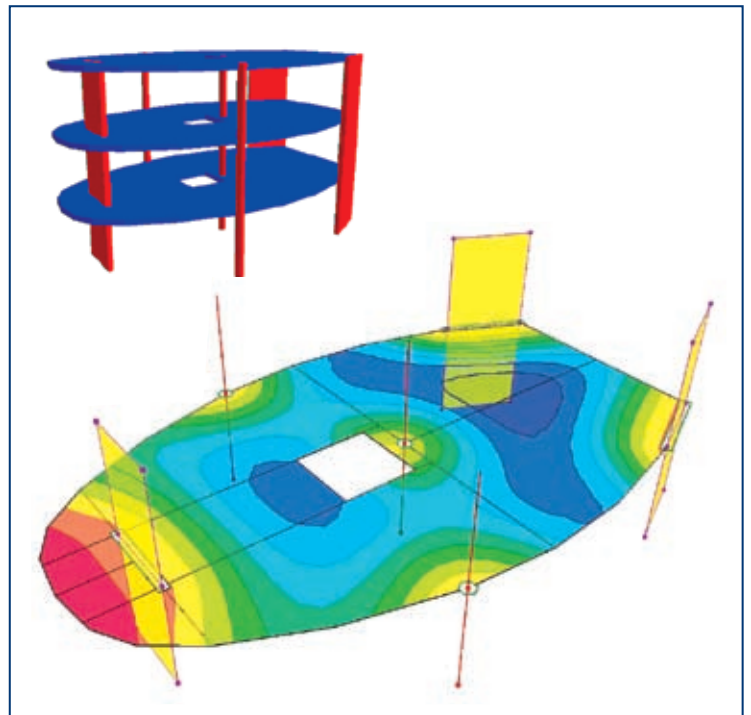

**Prediction of slab deflection using an FE analysis program**

(courtesy of CSC (UK) Ltd).



to be analysed is broken into elements that have a finite size. For a 2D surface such as a flat slab, these elements are either triangular or quadrilateral and are connected at nodes, which generally occur at the corners of the elements, thus creating a 'mesh'.

Parameters and analytical functions describe the behaviour of each element and are then used to generate a set of algebraic equations describing the displacements at each node, which can then be solved. The elements have a finite size and therefore the solution to these equations is approximate; the smaller the element the closer the approximation is to the true solution.

## History

FE methods generate numerous complex equations that are too complicated to be solved by hand; hence FE analysis was of interest only to academics and mathematicians until computers became available in the 1950s. FE methods were first applied to the design of the fuselage of jet aircraft, but soon it was civil and structural engineers who saw the potential for the design of complex structures. The first application to plate structures was by R J Melosh in 1961<sup>5</sup>. Initially, the use of FE required the designer to define the location of every node for each element by hand and then the data were entered as code that could be understood by a computer program written to solve the stiffness matrix. Nowadays this is often known as the 'solver'. The output was produced as text data only.

Many different solvers were developed, often by academic institutes. During the 1980s and 1990s graphical user interfaces were developed, which created the coded input files for the solver and then give graphical representation of the results. The user interface that creates the input files for the solver is often known as the pre-processor and the results are manipulated and presented using a post-processor.

This has considerably simplified the process of creating the model and interpreting the results. During the late 1990s and early 2000s the software was enhanced to carry out design as well as analysis. Initially the software post-processors would only calculate areas of reinforcing steel required, but more recently the ability to carry out deflection

calculations using cracked section properties has been included in some software.

## When to use FE analysis

A common myth is that FE will return lower bending moments and deflections than would be obtained using traditional methods. This is a false assumption as, unless previous techniques were overly conservative, it is unlikely that a different method of analysis would give more favourable results. In fact a comparative study carried out by Jones and Morrison<sup>6</sup> demonstrated that using FE methods for a rectangular grid gives similar results to other analysis methods including yield line and equivalent frame analysis. Therefore, for simple structures, there is no benefit in using FE analysis, and hand methods or specialised software are probably more time-efficient.

FE analysis is particularly useful when the slab has a complex geometry, large openings or for unusual loading situations. It may also be useful where an estimate of deflection is required.

## Initial sizing

Where FE is considered to be the correct tool for a project it will generally be used only for detailed design. Initial sizing should still be carried out using hand calculation methods such as:

- Span-to-effective-depth ratios
- Slab depths obtained from the publication *Economic concrete frame elements*<sup>7</sup> (see Table 1)
- Previous experience

Using FE methods is unlikely to give a slab that is significantly thinner than when using simple hand methods.

## Assumptions

In preparing this guide a number of assumptions have been made to avoid over-complication; the assumptions and their implications are as follows.

- **Only flat soffits considered** Only slabs with completely flat soffits are considered in this guide. Where drop heads and beams are also included in a model the following should be considered:

**Table 1**  
**Economic depths (mm) for multiple span flat slabs**

Imposed load	Span (m)								
	4	5	6	7	8	9	10	11	12
2.5	200	202	222	244	280	316	354	410	466
5.0	200	214	240	264	300	340	384	442	502
7.5	200	226	254	284	320	362	410	468	528
10.0	200	236	268	304	340	384	436	490	548

### Assumptions

- Class C28/35 concrete
- Super-imposed dead load of 1.5 kN/m<sup>2</sup>
- Perimeter load of 10 kN/m for cladding
- Fire resistance 1 hour (increase depth by 10 mm for 2 hours)
- Multiple spans (increase depth by 10 mm for 2 spans)
- No holes

- Most software will assume the centre of elements with different thickness will be aligned in the vertical plane, so the offset of the drop or beam should be defined in the model.
  - The output is usually in the form of contour plots, and there will be some interpretation required at the interface of elements with different thicknesses.
- **The frame is braced** It has been assumed that the lateral stability is in the form of stability cores or alternative system and that no additional moments are imposed on the column/slab interface due to frame action. Where a stability frame is used with a flat slab (recommended only for buildings with a limited number of storeys) then the impact on the modelling assumptions should be carefully considered. In particular, where the horizontal forces are due to geometric imperfections (notional horizontal loads), the long-term elastic modulus should be used because these are long-term loads.
  - **The concrete is not prestressed** The guidance in this document is not intended to be used for the design of post-tensioned flat slabs.

## Flat slab construction

### Definition

The term 'flat slab' has no universal definition. Eurocode 2<sup>1</sup> defines flat slabs as slabs supported on columns. BS 8110<sup>2</sup> explicitly includes waffle or coffered slabs. For the purpose of this guide, a flat slab is considered to be a reinforced concrete slab of constant thickness, which could include drop panels. However, this guide does not specifically discuss how to model drop panels.

### History of flat slabs

The flat slab was conceived as a structural system in the earliest days of reinforced concrete development. Credit for inventing the flat slab system is given to C A P Turner, and his system was described in *Engineering News* in October 1905, and reviewed in a more recent article<sup>3</sup>. Further development of the flat slab method was carried out by Robert Maillart and Arthur Lord, and in 1930 the use of flat slabs was codified in the 1930 London Building Act<sup>4</sup>.

## Types of software available

It is possible to model the whole building using a 3D frame analysis package; the main advantages are that column stiffness can automatically be included and that load takedowns are carried out. However, the models become large and complex, requiring significant computing power to solve the stiffness matrix as a complete model. It is therefore preferable to carry out an analysis on a floor-by-floor basis, either using a 3D package that allows this or by treating each slab as an individual model.

Increasingly, FE packages have been adapted for particular uses (e.g. reinforced concrete design) and many now include the ability to semi-automate the design of the reinforcement as well as carry out the analysis. Another feature that is almost standard is that CAD drawings can be imported.

Although the software is now relatively simple to use, engineers should still understand what the software is doing on their behalf and what default parameters have been assumed in the package, particularly for deflection calculations.

When selecting an FE software package it is important to understand what it is capable of calculating. A list of features and their importance are given in Table 2.

FE solvers can either use linear or non-linear analysis and the merits of these are discussed below.

### Linear analysis

This is currently the most widely used method of FE analysis, but it is less sophisticated than non-linear analysis. Reinforced concrete (RC) is treated as an elastic isotropic material, which it evidently is not, and a number of assumptions have to be made to allow this method to be used. These assumptions in the modelling can lead to misunderstanding of the results and further explanation of implications are discussed in the relevant sections throughout this guide.

A linear analysis is more than adequate for carrying out a design at the ultimate limit state. The serviceability limit state can be checked by using 'deemed to satisfy' span-to-effective-depth ratios or by using conservative values for the elastic modulus and slab stiffness. Typically, 85% of elements are designed using the span-to-effective-depth rules and this is considered to be perfectly adequate for the majority of designs. Even the most sophisticated analysis will only give an estimate of deflection in the range +15% to -30% .

### Non-linear analysis

Many FE packages are capable of carrying out non-linear (iterative) analysis, but this is useful only for reinforced concrete design where it can be used to model the cracked behaviour of concrete. Non-linear analysis is used for RC design because as the slab is loaded it will crack and this affects its stiffness. The program carries out an analysis with uncracked section properties; it can then calculate where the slab has cracked, adjust the material properties and run the analysis again. This process continues until the variation in section properties between runs reaches a predetermined tolerance.

A more sophisticated method is to also model the yielding of the reinforcement where it reaches the elastic limit. This requires advanced software and is generally used only for specialist situations; it is outside the scope of this guide.

# FE analysis and design procedure

A recommended process of design using FE analysis is given in Figure 1, and commentary is provided below.

## What results are to be expected?

Before any analysis is carried out using computer software it is always good practice to carry out some simple hand calculations that can

be used to verify that the results are reasonable. It is particularly important to do this when using FE, and not treat the computer as a 'black box'. Simple calculations can be carried out to determine the 'free bending moment', i.e. calculate  $wL^2/8$  for a span and then check that the FE results give the same value between the peak hogging and sagging moments. A discrepancy of 20% is acceptable; outside of this limit further investigation should be carried out to determine the reasons. Calculate the total load on the slab and compare these against the sum of the reactions from the model. Always include any hand checks in your calculations.

**Table 2**  
Software features

Feature	Benefit	Is it required?
<b>Features applicable for all types of FE analysis</b>		
The bending moments in orthogonal directions take account of the torsion moment (e.g. are Wood Armer moments or similar methods included?)	Allows the design of the reinforcement to resist the full design moments	Essential
Automatic mesh generation	Saves time on creating the mesh. A good mesh generator will save much time on refinements at critical locations	No, but extremely useful
Columns and walls are entered as features in the model and their stiffness is calculated by the software	This is a more efficient method than calculating rotational spring supports by hand	No, but extremely useful
The area of the columns is automatically modelled as relatively stiff elements by software	This will realistically reduce the deflections compared with a point support	No, but will give more realistic results for edge columns and will have economic benefits
Area of reinforcement calculated by the software	Enables contour plots to be generated showing areas of steel as well as bending moments	No, but useful
Software analyses in-plane slab forces and considers variations in slab centroid elevation	Allows realistic analysis of slabs with varying thicknesses	If slab is not of uniform thickness (unless slab centroid elevation is uniform) or contains beams
Automatic application of load patterns to determine worst case design forces	Ensures the worst combinations of forces are obtained	No, the 'worst credible' load arrangements can be found using a limited number of load patterns
<b>Features applicable where estimated deflections are required</b>		
Curvature due to free shrinkage strain calculated	A requirement of BS 8110 and Eurocode 2 for determining deflections	Yes, where estimated deflections are required
Cracked section properties calculated for every element and recalculated for subsequent iterations	Cracked section properties vary throughout the slab	Yes, where estimated deflections are required
Cracked section properties calculated in each direction	Cracked section properties vary in each direction	Yes, where estimated deflections are required
Partially cracked properties are calculated	Tensioning stiffening will prevent a fully cracked situation	Yes, where estimated deflections are required
Separate analysis used for ULS and SLS	Less cracking occurs at the SLS, so the slab is more stiff	Yes, where estimated deflections are required
Software calculates creep coefficients, tensile strength and free shrinkage strains for each change in loading throughout the life of the slab.	Saves calculating by hand	No
Proposed reinforcement arrangements can be applied to the model	The size and distribution of the bars affects the cracking and crack patterns	Yes, where estimated deflections are required
<b>Features applicable for design using FE software</b>		
Areas of required reinforcement can be averaged over a specified width	This automation saves time	No, but useful

## Analysis

Having carried out the initial sizing and calculated the expected magnitude of the results an FE model can be created. The initial results should be used to determine the ultimate limit state (ULS) requirements. From these results a preliminary bar size and layout can be determined. These are required in order to determine the stiffness of the slab, which is essential for checking the serviceability criteria.

## Check serviceability criteria

After determining the slab stiffness and the elastic modulus, the estimated deflection can be calculated using this data in the FE model, and checked against acceptance criteria.

Additional reinforcement may be added in the mid-span to control deflection, but it is important to remember that this will increase the stiffness in the middle of the slab. Therefore the model should be re-analysed and the ULS checked again. Note that where the span-to-

effective-depth ratios from Eurocode 2 are applied the UK National Annex allows only 50% extra reinforcement to be used for deflection control.

## Governing criteria

Punching shear and deflection control are usually the governing criteria for flat slabs. Punching shear should be checked using code rules.

Deflection in concrete is a complex phenomenon, which is dependent on the final tensile and compressive strength, elastic modulus, shrinkage, creep, ambient conditions, restraint, loading, time and duration of loading, and cracking of the member (see Panel 1). Many of these factors are inter-related and often difficult to assess. Deflection prediction is based on assumptions and is therefore an estimate – even when using the most sophisticated computer software.

Importantly, deflection in a reinforced concrete slab is dependant on the age at first loading and the duration of the load because it will

**Figure 1**  
Design process using FE analysis

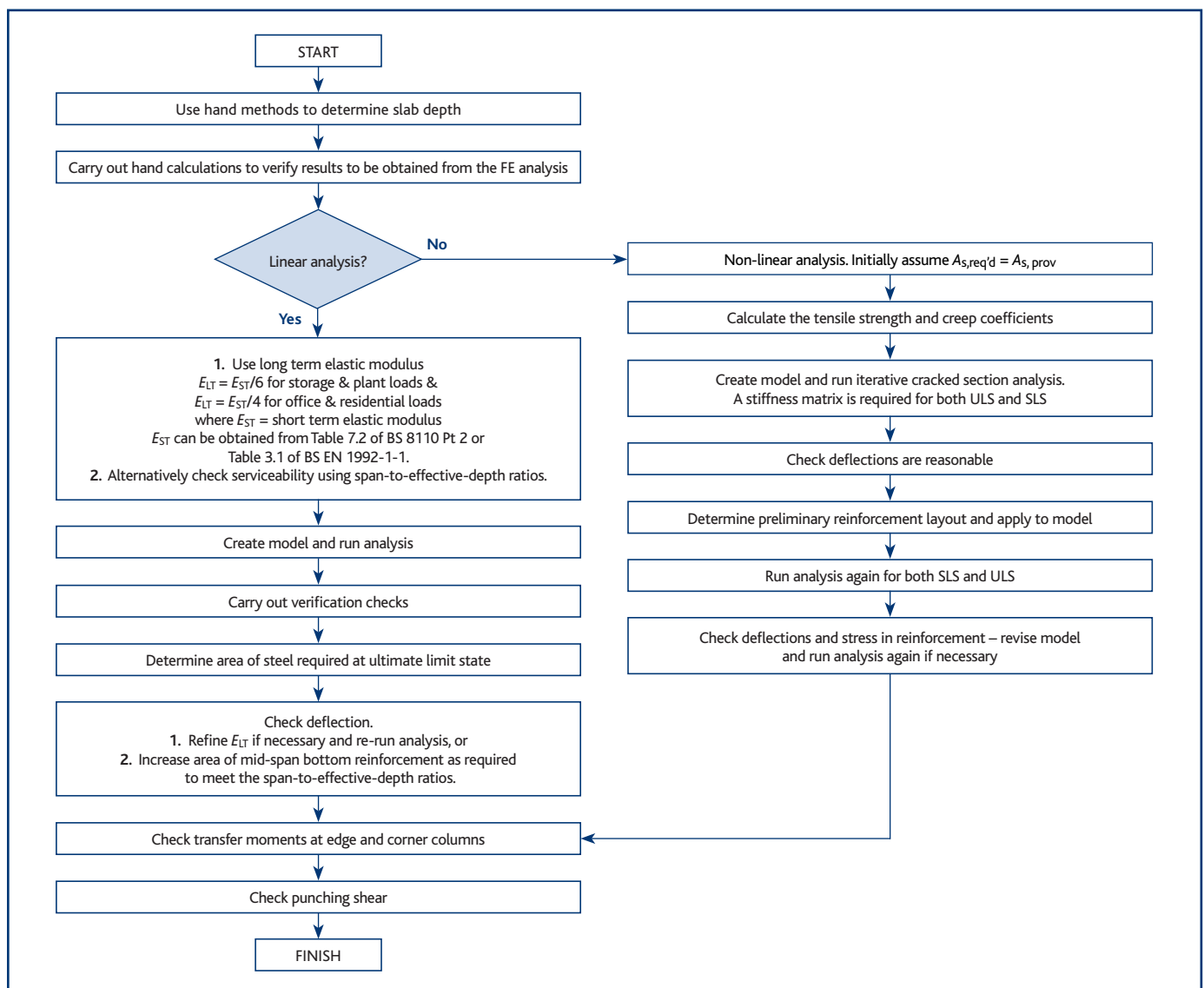

influence the point at which the slab has cracked (if at all) and is used to calculate the creep factors. A typical loading sequence is shown in Figure 2, which shows that in the early stages relatively high loads are imposed immediately after casting the slab above. Once a slab has 'cracked' it will remain cracked and the stiffness is permanently reduced.

## Methods of analysis and code requirements

FE is not the only method for analysing flat slabs. In addition to the tabular method and elastic frame methods described in the

Codes, the yield line or grillage methods can also be used. (subject to Cl 9.4 of Eurocode 2-1-1).

Some engineers are inclined to believe that by using FE analysis the Code requirements do not apply; in particular they consider that there is no need to check the maximum permissible transfer moments between the slab and column. However, it needs to be understood that FE is an elastic method, just like the elastic frame method described in the Codes, and the provisions of Eurocode 2 Annex I.1.2(5) or BS 8110 Cl.3.7.4.2 and 3.7.4.3 should still be applied.

### What affects deflection?

There are numerous factors that affect deflection. These factors are also often time-related and interdependent, which makes the prediction of deflection difficult.

The main factors are:

- Concrete tensile strength
- Creep
- Elastic modulus

Other factors include:

- Degree of restraint
- Magnitude of loading
- Time of loading
- Duration of loading
- Cracking of the concrete
- Shrinkage
- Ambient conditions
- Secondary load-paths
- Stiffening by other elements

## Creating an FE model

### Properties of concrete

Reinforced concrete is a complex material, consisting of reinforcing steel, aggregates, water, cementitious material, admixtures, and probably voids and un-hydrated cement. The properties of concrete are affected significantly by the different types of aggregate and by the varying proportions of the constituent materials. The properties of concrete are also affected by workmanship, weather, curing conditions and age of loading.

Both BS 8110 and Eurocode 2 allow reinforced concrete to be modelled as an elastic isotropic material. Clearly this requires a number of assumptions to be made and the limitations of these assumptions should be fully understood by the designer. The impact of these assumptions will be discussed later in this guide. The deflection of the slab is mainly dependant on tensile strength, creep and elastic modulus.

**Figure 2**  
Loading history for a slab

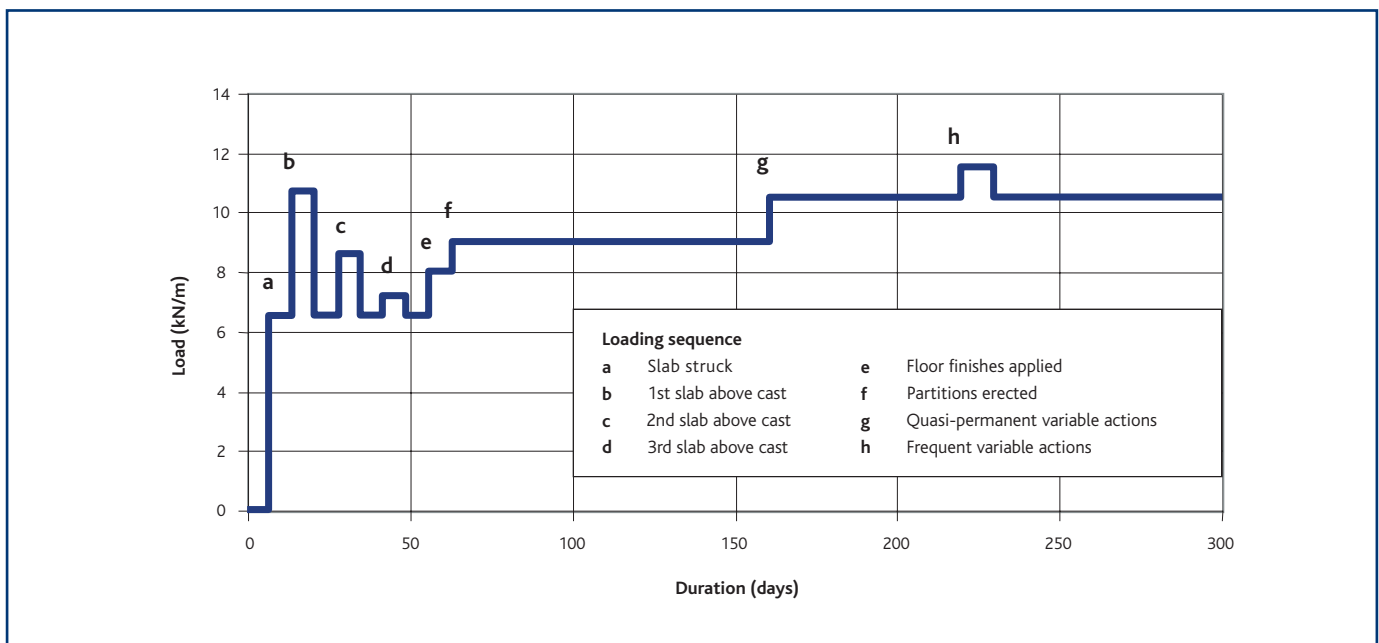

- Tensile strength** The tensile strength of concrete is an important property; the slab will crack when the tensile strength stress in the extreme fibre is exceeded. In BS 8110 the flexural tensile strength is always taken as  $1 \text{ N/mm}^2$  at the level of the reinforcement, whereas in Eurocode 2 the tensile strength,  $f_{ctm}$ , is compared with the stress at the extreme fibre.  $f_{ctm}$  is a mean value (which is appropriate for deflection calculations) and increases as the compressive strength increases.
- Creep** This is the increase in compressive strain in a concrete element under constant compressive stress. It increases with time. Creep is usually considered in the design by modifying the elastic modulus using a creep coefficient,  $\varphi$ , which depends on the age at loading, size and ambient conditions. BS 8110 and Eurocode 2 both give advice on the appropriate relative humidity for indoor and outdoor conditions.
- Elastic modulus** The elastic modulus of concrete varies, depending on aggregate type, workmanship and curing conditions. It also changes over time due to the effect of creep. These factors mean that some judgement is required to determine an appropriate elastic modulus. BS 8110 and Eurocode 2 both give recommended values for the short-term elastic modulus. BS 8110 gives a range and a mean value, whereas Eurocode 2 gives a single value with recommendations for adjustments depending on the type of aggregate used. The latter is more useful, if it can be established which type of aggregates will be used. A long-term elastic modulus is obtained from applying a creep factor, and advice is given in both BS 8110 and Eurocode 2.

The assessment of the long-term elastic modulus can be carried out more accurately after a contractor has been appointed because he should be able to identify the concrete supplier (and hence the type of aggregate) and also the construction sequence (and hence the age at first loading).

The choice of elastic modulus is particularly critical when using linear FE analysis to check serviceability criteria, as the deflection results are directly related to its value. Where FE is being used for

design of the ULS only, the elastic modulus is not usually critical because the results should always be in equilibrium.

- Poisson's ratio** A value of 0.2 should be used for Poisson's ratio.

## Element types

When carrying out FE analysis, the selection of a particular type of element is no longer necessary as most commercially available software packages for flat slab design do not offer an option. For reference it is usual to use a 'plate' element; this will provide results for flexure, shear and displacement. In the future it is likely that membrane action will be modelled and considered in the design, in which case a 'shell' element would be used.

Plate and shell elements are generally triangular or quadrilateral with a node at each corner (see Figure 3). However, elements have been developed that include an additional node on each side, this gives triangle elements with six nodes and quadrilateral elements with eight nodes. Since the only places where the forces are accurately calculated are at the nodes (they are interpolated at other positions), the accuracy of the model is directly related to the number of nodes. By introducing more nodes into an element the accuracy of the results is increased; alternatively, the number of elements can be reduced for the same number of nodes, so reducing computational time.

Where the slab is deep in relation to its span (span-to-depth  $< 10$ ) plate elements are not the most appropriate (unless shear deformation is modelled) and 3D elements should be used; these are outside the scope of this guide.

## Meshing

The term 'mesh' is used to describe the sub-division of surface members into elements (see Figure 4), with a finer mesh giving more accurate results. The engineer has to assess how fine the mesh should be; a coarse mesh may not give an accurate representation of the forces, especially in locations where the stresses change quickly in a short space e.g. at supports, near openings or under point loads. This is because

**Figure 3**  
Types of element

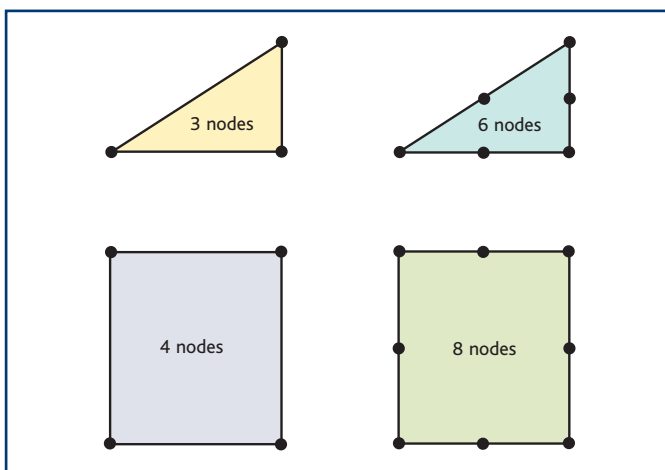

**Figure 4**  
Typical mesh

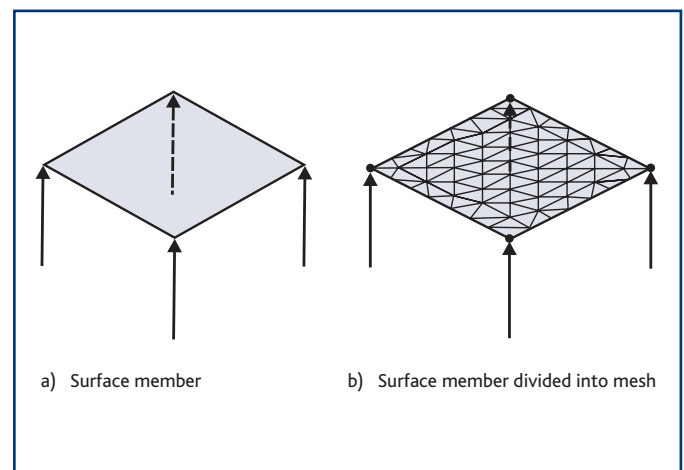

there are insufficient nodes and the results are based on interpolations between the nodes. However, a very fine mesh will take an excessive time to compute, and is subject to the law of diminishing returns.

The importance of selecting the correct mesh size is illustrated in Figure 5. The same model was analysed three times with the only change being the maximum mesh size. Where a very coarse mesh was used (up to 5000 mm) it took just 30 seconds to analyse; although it is analytically correct it does not give sufficient detail. Conversely, when a much finer mesh was used (up to 500 mm) it took 15 minutes to analyse and gives the shape of bending moment diagram that would be expected. However, a mesh up to 1000 mm took just four minutes to analyse; it gave very similar results and is considered to be sufficiently accurate for the purpose of structural design.

As the processing speed of computers increases there will be less need to be concerned about optimising the mesh size; but it is worth noting that, although the 500 mm mesh gave notionally more accurate results, the reinforcement provision would have been identical for both the 500 and 1000 mm mesh spacings.

The 500 mm mesh has produced a higher peak moment; this is due to 'singularities' or infinite stresses and internal forces that occur at the location of high point loads. This is due to assumptions that have been made in the model. In flat slabs the concrete will crack and the reinforcement yield locally and thus distribute the forces to adjacent areas.

Definitive advice cannot be given as to the ideal size mesh size, but a good starting point is for elements to be not greater than span/10 or 1000 mm, whichever is the smallest.

For large models it is worth running the initial analysis with a coarse mesh, which can then be refined when the model has been proved to be free of errors or warnings and gives reasonable results. With most software packages the meshing is carried out automatically and the software can even reduce the element size at critical locations to obtain more data where it is most needed. This will give more detailed results without a significant increase in analysis time.

## Element shape

Elements should be 'well conditioned', i.e. the ratio of maximum to minimum length of the sides should not exceed 2 to 1 (See Figure 6). Again this is because the results are accurately calculated only at the node positions. It is important to ensure that there are more nodes included in the model where the forces change rapidly because it is only at node locations that results are obtained directly; in between the nodes the results given are based on interpolation.

**Figure 6**  
Element shape

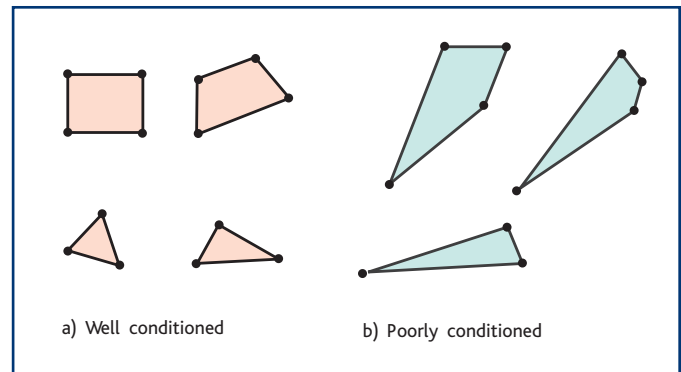

**Figure 5**  
Bending moments: accuracy of results compared with mesh size

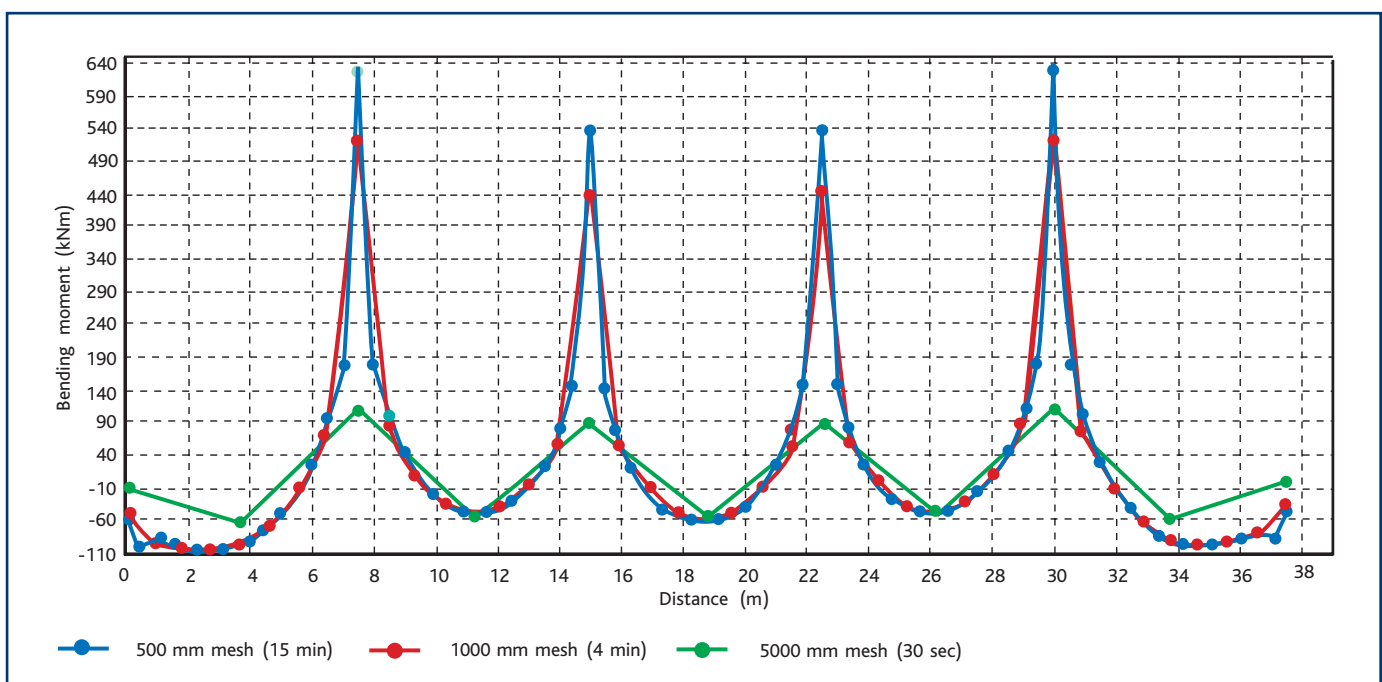



## Supports

It is important to correctly model the support conditions to ensure that resulting bending moments at the supports and in the mid-span are realistic. It will also enable column moments to be derived and punching shear stress to be realistically evaluated. Where bending is induced in the columns, i.e. for a monolithic frame, the stiffness of the column should be modelled; this is particularly true for edge and corner columns. Where these columns are modelled with vertical point supports only, the bending moments at the interior columns and spans can be underestimated. This can also lead to inaccuracies in the local forces around the supports.

These potential errors, combined with the potential for deflection results at mid-span to be increased by 10% when using point supports, mean that the area of the column should be modelled. This can be achieved in two ways. Either by inserting a thicker region in the slab to match the plan area of the column, or by using rigid arms between the column centreline and its perimeter (see Figure 7). Neither is a perfect solution, but both are more realistic than a point support.

The stiffness of the columns should be modelled by using rotational spring stiffness. For a pin-ended column the stiffness can be taken as

$K = 3EI/l$  and for a fully fixed column  $K = 4EI/l$  (see Figure 8). However, for columns supporting the upper storeys, edges and corners the end condition will not be fully fixed and cracking can occur that will reduce their stiffness. Further if edge and corner columns are made too stiff they will attract more moment to them, which may exceed the maximum transfer moment.

The rules for governing the maximum moment that can be transferred between the slabs and the column are given in Eurocode 2, Annex I:1.2.(5) or in BS 8110 Cl. 3.7.4.2 & 3.7.4.3. These rules are applicable even when using FE analysis. If the maximum transfer moment is exceeded the design sagging moment should be increased to reduce the hogging moment at the critical support.

For non-symmetrical columns the stiffness will be different in each direction. Many modern FE packages will automatically calculate the spring stiffness, and all the user is required to do is enter the column dimensions.

Other problems with supports can occur at the ends of walls and where columns are closely spaced. In these situations the results will show sharp peaks in the bending moments, shear forces and support reactions (see Figure 9). This is due to singularity (infinite stresses) problems that occur with linear-elastic models. In reality these peaks do not exist in the concrete because it will crack and yield. Modelling this behaviour is difficult using linear elastic behaviour, but one method is to use vertical spring supports near the ends of walls to spread the peak support reaction on the end node to adjacent nodes. Some programs include features designed to deal with this situation.

**Figure 7**  
Alternative methods for modelling the area of the column

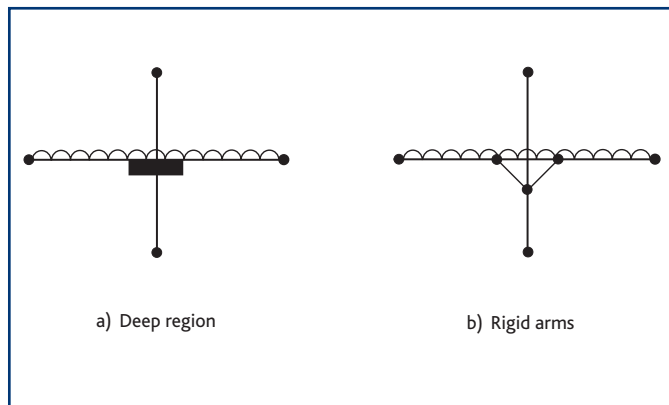

**Figure 8**  
Modelling column stiffness

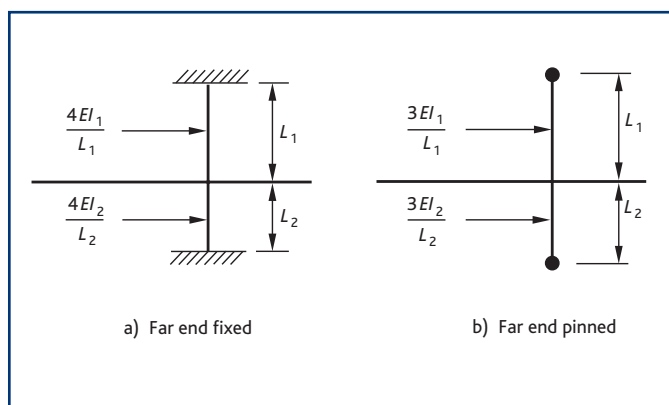

**Figure 9**  
Support forces in interrupted line support

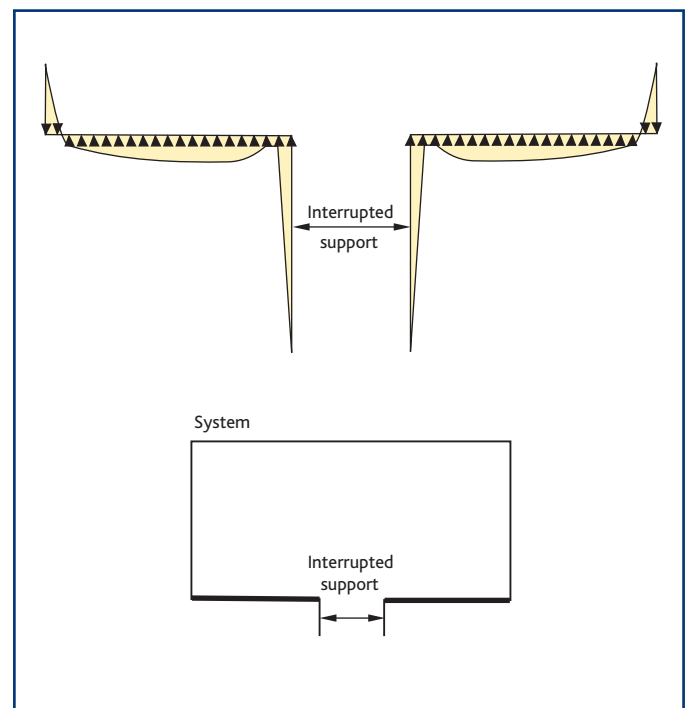

**Figure 10**  
Load arrangements for flat slabs

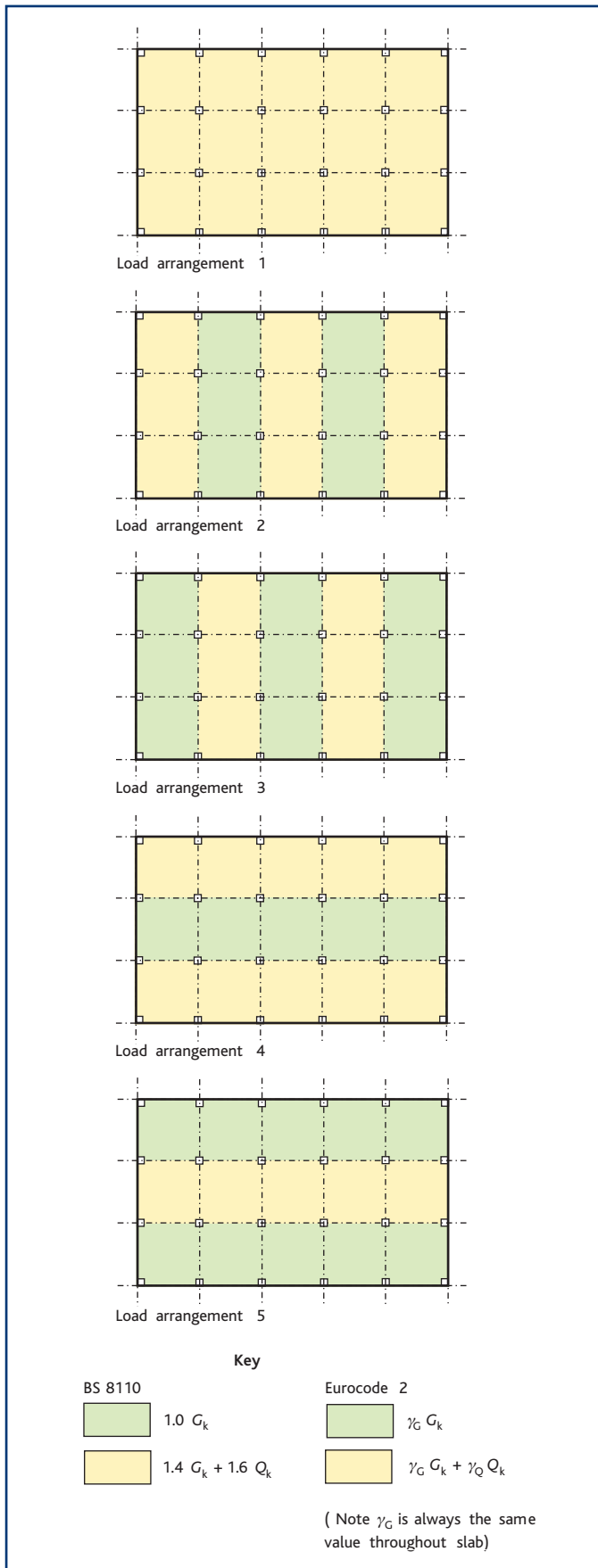

## Loading

All software will allow a number of load cases to be considered, and the engineer must assess how to treat pattern loading. It requires engineering judgement to determine the 'most unfavourable arrangement of design loads' for a floor plate with an unusual geometry. However, Eurocode 2 gives some specific guidance in Annex I on how to deal with loading for unusual layouts.

Where pattern loading is to be considered, the maximum span moments for flat slabs designed to BS 8110 can be obtained by using the combination of unfactored dead load over the full length of a bay alternating with the factored dead and live loading across the full length of the adjacent bay (see Figure 10, arrangements 2 to 5).

When designing using Eurocode 2 the combination of the full factored dead load over the whole slab together with the factored live loading on alternate bays should be used (see Figure 10). These should be considered separately in each orthogonal direction. Note that a 'chequer-board' pattern loading is an unlikely pattern and may not give the most unfavourable arrangements.

The engineer should be aware that problems can occur in the way FE programs assign forces to the nodes of the elements (see Figure 11). In Figure 11a), a uniformly distributed load is applied to a beam using finite elements that are a third of the length of the beam. The software will determine the load to be applied to each node based on the parametric functions of the element type being used. In this case the load is apportioned equally to the node at either end of the element. The analysis gives an approximation only of the bending moments and shear forces. In Figure 11b) a central point load is analysed as two point loads at one third distances, which gives incorrect bending moments and shear forces. Finally in Figure 11c) an upwards load on the middle element of the beam leads the FE software to calculate there is no load at all on the beam and hence no forces.

The conclusions to draw are that the mesh needs to be more refined if patch loads are applied to a model and that a node should always be placed at the location of a large point load. Some software may apply a corrective moment where point loads do not coincide with nodes. If this is the case and the user is relying on this feature, the results should be validated.

For non-linear cracked section analysis, two stiffness matrices will be required, one each for the ULS and SLS. This is because the slab is almost certainly not fully cracked at the SLS and the material properties will be different from those at the ULS. The loads should be assigned to both cases with appropriate partial factors.

## Validation

As with any analysis it is necessary to validate the results in order to avoid errors in the modelling and input of data. There is a risk of engineers assuming that because the computer can accurately and rapidly carry out complex calculations it must be right. The failure

of the Sleipner a platform in the North Sea in 1991 is a sobering reminder of what can happen when it is assumed that the results from a FE model are correct. As the platform was being lowered into position one of the cell walls failed, which led to the destruction of the whole structure. One reason for the failure was that the mesh was too coarse in a critical location to detect the peak forces. The total financial cost of the disaster has been calculated as \$700M; fortunately there was no loss of life.

There are number of simple checks of the analysis that must be carried out and the results of these checks should always be included when the calculations are presented.

- Are the supports correctly modelled?
- Is the element size appropriate – particularly at locations with high stress concentrations?
- Is there static equilibrium? Calculate by hand the total applied loads and compare these with the sum of the reactions from the model results.
- Carry out simplified calculations, by making approximations if necessary. (This could be done by using yield line methods or the RC spreadsheets<sup>11</sup>). If the FE results vary from these calculations by more than 20% the cause will need to be investigated .
- Do the contour plots look right? Are the peak deflections and moments where they would be expected? Sketch out by hand the expected results before carrying out the analysis.
- Is the span-to-effective-depth ratio in line with normal practice (see Table 1).

These checks should always be carried out before any attempt is made to design the reinforcement.

The engineer should be confident the software is doing what is expected. Most 'solvers' have a good track record and can be used with confidence to obtain analysis results (provided the input data is correct and assumptions understood). However, the design post-processors are less tried and tested. The engineer should be satisfied that the design of the reinforcement, particularly for the deflection calculations, is being carried out as expected. When new software is being used some validation against known benchmarks should be carried out.

It would also be of assistance to the practicing engineer if a summary sheet of assumptions and design methods built into the software were provided so they can be easily assimilated.

## Ultimate limit state design

### Twisting moments

Treating reinforced concrete as an elastic isotropic material can lead to problems in interpreting the bending moment results. The output from an FE analysis of plate elements will give bending moments in the x and y directions,  $M_x$  and  $M_y$ . However, it will also give the local twisting moment  $M_{xy}$  (see Figure 12). This moment is significant and

**Figure 11**  
Support forces in interrupted line support

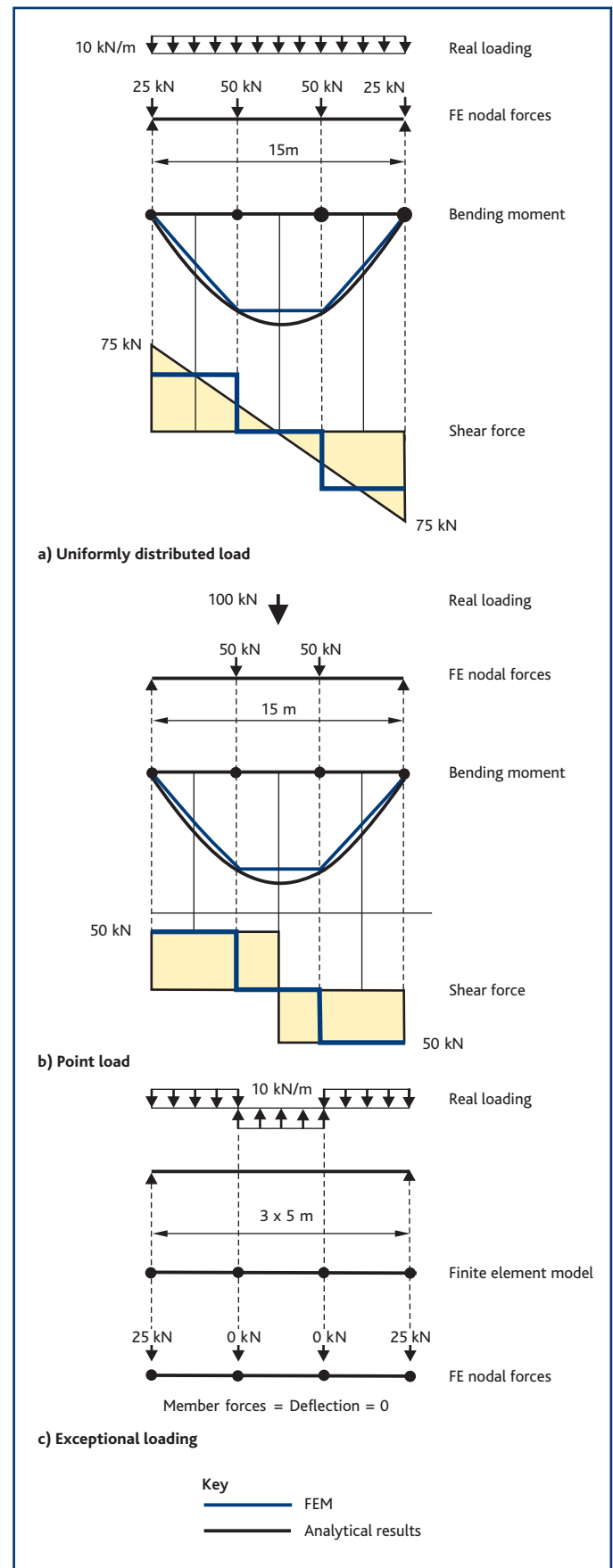

must be considered in the reinforcement design.  $M_{xy}$  does not act in the direction of the reinforcement and a method is required to allow for  $M_{xy}$  in the design. A popular method in the UK is known as Wood Armer moments, although it is not the only method used. Most software will calculate Wood Armer moments for the user. They have four components, top (hogging) moments in the x and y directions,  $M_x(T)$  and  $M_y(T)$ , and bottom (sagging) moments in each direction,  $M_x(B)$  and  $M_y(B)$ . The method is slightly conservative and these moments form an envelope of the worst-case design moments. It is possible to have both  $M_x(T)$  and  $M_x(B)$  moments at the same location in the slab (usually near the point of zero shear).

The four components can be used directly to calculate the required reinforcement for each of the four reinforcement layers in a flat slab.

**Figure 12**  
Design bending moments compared with FE output

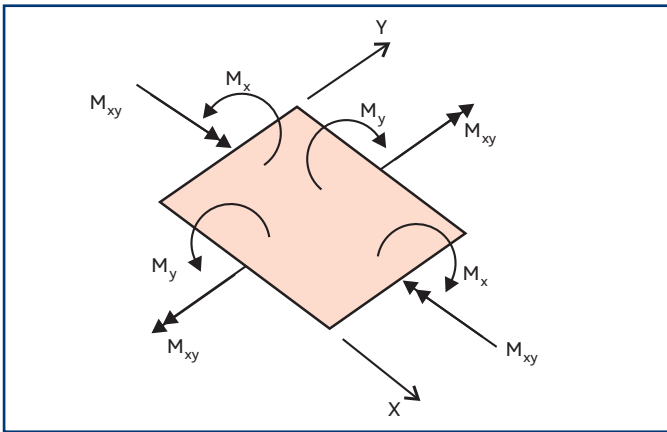

## Design moment adjustment

Where high peak moments occur the concrete will crack and the reinforcement may yield if its the elastic limit is exceeded. The forces are then shed to the surrounding areas. Even if a slab were designed to resist this moment it is unlikely that it would actually achieve this capacity for the following reasons:

- The construction process often leads to construction stage overload.
- The reinforcement is unlikely to be placed at exactly the point of peak moment.

It is therefore necessary to acknowledge that some shedding of the peak moments to adjacent areas will occur due to the material properties of concrete, and not attempt to design against it. In fact a recent paper by Scott and Whittle<sup>13</sup> concluded that redistribution occurs even at the SLS because of the mismatch between the uniform flexural stiffnesses assumed and the variation in actual stiffness that occurs because of the variations in the reinforcement.

When using FE, especially for slabs with irregular geometry, it is not usually possible to carry out redistribution of the moments for the following reasons:

- It is not simple to determine where to distribute the hogging moment to.
- If the software is carrying out the design there is usually no method for changing the analysis output.

In the future, software that models the yielding of the reinforcement will automatically redistribute the moments and find an equilibrium solution.

## Punching shear

Although an FE model will produce shear stresses, where the columns are modelled as pins they have no effective shear perimeter and the shear force is infinite. In this case the simplest way to check punching shear is to take the reactions from the model and carry out the checks in the normal way using the provisions in the codes of practice. This can be automated by using a spreadsheet for the design of reinforced concrete<sup>11</sup>.

If the area of the column has been modelled, then realistic shear stresses can be obtained, but some engineering judgement may be required in using them because there will be peaks which may exceed the design limits in the codes.

Some software can undertake the punching shear checks and design of the reinforcement, and the user should ensure that openings within the shear perimeter are considered in the software.

## Interpreting results

The results from an FE analysis will generally be in the form of contour plots of stresses and forces, although a 'section' through the contour plots (either bending moment or areas of steel) can usually be obtained. These will show very large peaks in bending moment at the supports. The temptation to provide reinforcement to resist this peak moment should be avoided. This potential error stems from a lack of understanding of the assumptions made in the modelling. The reinforcement in the concrete will yield at the support position and the moment will be distributed across a larger area; it is not therefore necessary to design to resist this peak moment. However, a method is required for distributing this peak moment across a larger area.

BS 8110 and Eurocode 2 deal with the peak in bending moment for flat slabs by averaging it over the column strip and middle strips (CL.3.7.2.8, BS 8110 and Annex I, Eurocode 2), with the columns strip sub-divided into inner and outer areas. This method can be used for designing reinforcement using the results of an FE analysis. A section is taken across the bending moment diagram (i.e. in the y direction for moments in the x direction) at the face of the column (the blue line in Figure 13). The total bending moment is the area under the blue line (i.e. the integral), which can be apportioned according to rules given BS 8110 or Eurocode 2.

If the BS 8110 principles are adopted then the design moments would be as shown by the red line in Figure 13. Here three-quarters of the total moment is apportioned to the column strip (which is half the

bay width) and of this two-thirds is apportioned to the inner column strip. The remaining column strip moments are assigned to the outer areas and the middle strip moment is distributed equally across the remaining bay width.

The rules in Eurocode 2, Annex I (Table I.1) allow more flexibility in apportioning the total moment for the bay width to the column and middle strips. However, Eurocode 2 is more rigid in terms of how much reinforcement should be applied to the inner column strip. Cl. 9.4.1(2) requires that half the total reinforcement area for the bay width is placed in a strip that extends to a quarter of the bay width and is centred over the support.

**Figure 13**  
Design bending moments compared with FE output

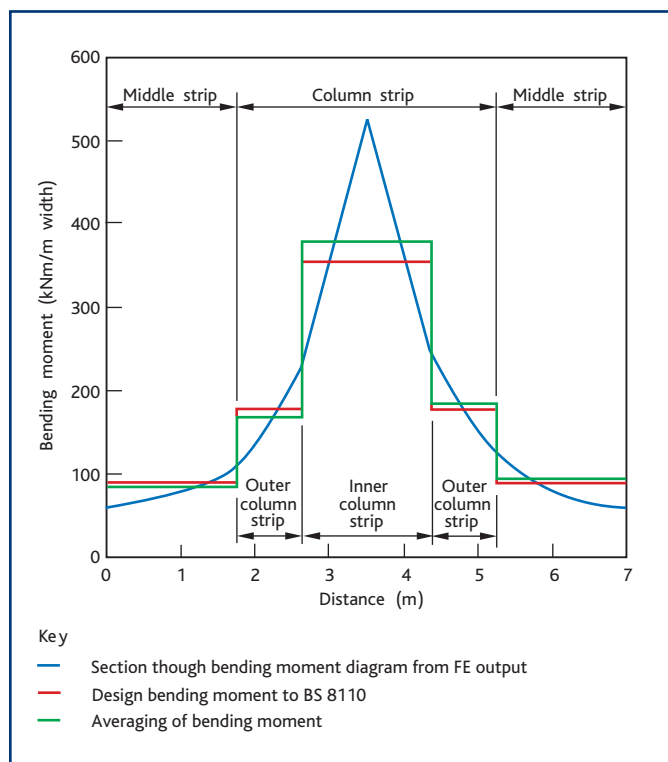

**Figure 14**  
Extract of shear diagram indicating lines of zero shear

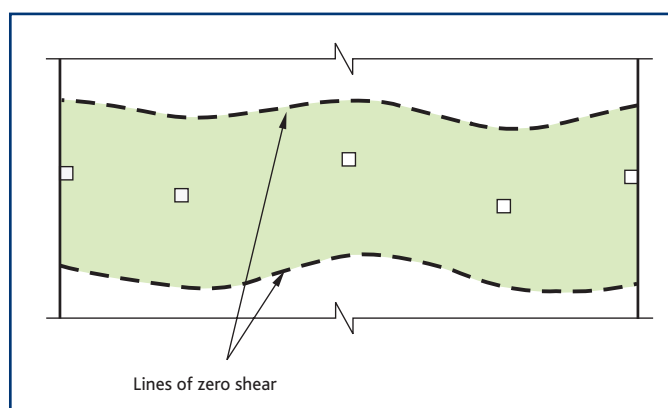

Both BS 8110 (Cl. 3.7.2.6) and Eurocode 2 (Cl. 5.3.2.2 (3) & (4)) allow the design moment to be taken at the face of the support, indeed Eurocode 2 indicates this should be done. However, it may be prudent for the design moment at edge columns to be taken at the centre of the support. This is because of uncertainties in the modelling and because it is critical that the moment is transferred from the slab to the column in these locations, if this has been assumed in the design.

An alternative method is to simply average the bending moment over a width of slab. However, if designing to Eurocode 2 the requirements of Cl.9.4.1(2) should be adopted. The widths of these strips can be determined by the designer; an example is shown by the green line in Figure 13. Here the same strip widths as the BS 8110 method have been adopted to show how the results compare. This method has the advantage that it can be used for a slab with irregular geometry, because a fixed bay width is not required. It can also be used with area of steel results, removing the need to calculate the reinforcement areas by hand. It will be seen that both methods give a similar distribution of reinforcement when applied to the same strip widths.

An alternative way of determining design bay width is to use the method set out in Concrete Society report TR43<sup>14</sup>. This method has been developed for post-tensioned concrete design, assuming the analysis is at the serviceability limit state and for a homogeneous elastic plate. However, the principle that the bay width is taken as being the distance between the lines of 'zero shear' may still be applied (see Figure 14). This principle is particularly useful for unusual geometries where using the lines of zero shear give a good basis on which to determine the bay widths.

Whichever method is chosen, engineering judgement should be applied for unusual situations, making sure that there is sufficient reinforcement to resist the applied moment, without being overly-conservative.

A useful rule of thumb for verifying the results is that top reinforcement in the column strip will be in the order of twice the area of the bottom reinforcement (i.e. not the same as, or 4 times as much as, the bottom reinforcement).

## Serviceability limit state design

The design of flat slab floors is usually governed by the serviceability requirements. Deflection is influenced by many factors, including the tensile and compressive strength of the concrete, the elastic modulus, shrinkage, creep, ambient conditions, restraint, loading, time, duration of loading, and cracking. With so many influences, and many which are difficult to accurately predict, the deflection calculation should be regarded as an estimate only. Concrete Society report *Deflections in concrete slabs and beams*<sup>8</sup> advises that the difference between calculated and actual deflections falls in the range +15% to -30%

even for rigorous calculation methods such as non-linear FE analysis. The engineer would be well advised to include this caveat when informing clients, contractors and other designers of predicted deflections.

Of the influences listed above, the three most critical factors are the values of tensile strength, elastic modulus and creep; their effects have been discussed previously.

There are several situations where deflections are critical:

- Deflection of the slab perimeter supporting cladding brackets/ fixings on the slab perimeter prior to installation of the cladding.
- Deflection of the slab perimeter after installation of the cladding.
- Deflection of the slab after erection of the partitions.
- Where it affects the appearance.

The designer will have to decide which of these apply to an individual project. Often the load which affects the critical deflection (e.g. deflection affecting cladding) is not applied at the same time as the initial loading; in this case the critical deflection can be calculated as follows:

$$\text{Critical deflection} = \text{Long-term deflection} - \text{Deflection prior to critical loading being applied}$$

This is because deflection is related to creep and the deflection due to a critical loading situation cannot be calculated directly.

The accuracy of the deflection calculation can be refined where the age of loading can be confidently predicted and the type of aggregates to be used is known. This is more likely to be the case where the designer is working for a contractor or the contractor is part of the design team. The time of striking and the time when additional formwork loads from the slab above are applied will have a major influence on the deflection. This is because the slab is most likely to crack under these conditions and this will greatly influence the subsequent stiffness of the slab. The elastic modulus can be more accurately predicted when the type of aggregate in the concrete is known, and this is more likely to be the case when the source of concrete has been determined.

Where the loading sequence is known, the critical loading stage at which cracking first occurs can be established by calculating  $K$  for each stage where:

$$K = f_{ctm} / (W\sqrt{\beta})$$

where

$f_{ctm}$  = Tensile strength of the concrete

$W$  = Loads applied at that stage

$\beta$  = 0.5 for long-term loads

The critical load stage is where  $K$  is at its minimum and is usually when the slab above is cast (i.e. construction stage overload), and the tensile strength should be calculated for this stage. The creep coefficient can be determined from Section 7.3 of BS 8110 Part 2, or Annex B of Eurocode 2. The Eurocode 2 creep factor allows for a decrease over time in effective elastic modulus.

## Approaches to deflection calculation

The following methods can be used to carry out serviceability limit state design. They are listed in order of increasing sophistication:

- Span-to-effective-depth ratios – compliance with code.
- Linear finite element analysis with adjustment of elastic modulus.
- Non-linear finite element analysis.

The first method should need no further explanation (guidance is given in both BS 8110 and Eurocode 2); it is the most popular method for checking deflection and, where the criteria are met, there is no need to carry out any further checks unless a predicted deflection is required. The other methods are discussed below.

## Linear FE deflection analysis

The linear finite element method should be used only to confirm that deflection is not critical and not a tool to estimate deflection. This method involves calculating the elastic modulus and slab stiffness by hand and adjusting the parameters used in the analysis. A cracked section analysis is carried out to determine the stiffness of the slab. The cracked section properties vary with the reinforcement size and layout, so this is an iterative process and should ideally be carried out for each element in the slab. However, for initial sizing it is not unreasonable to assume that the cracked section stiffness is half the gross section stiffness<sup>15</sup>, or to use a cracked section stiffness for a critical area of the slab and apply it globally, provided that it is not used to estimate deflection.

Changing the slab stiffness in an FE model cannot usually be carried out directly because most finite element packages calculate section properties from the thickness of the elements. The overall depth of the concrete should be used, as this gives the correct torsional constant. However, to allow for a reduction in slab stiffness, the elastic modulus can be adjusted by multiplying by the ratio of the cracked to uncracked slab stiffness,  $R$ , to model the correct slab thickness. So an appropriate long-term elastic modulus is  $R E_{ST} / (1 + \varphi)$  where  $E_{ST}$  is the short-term elastic modulus and  $\varphi$  is the creep factor, which can be determined from Section 7.3 of BS 8110 Part 2, or Annex B of Eurocode 2.

In general, the long-term elastic modulus is usually between a third (for storage loads) and a half (for residential loads) of the short-term value<sup>15</sup>. Therefore, allowing for the need to adjust for cracked stiffness, the long-term elastic modulus should be in the range one sixth to a quarter of the short-term elastic modulus.

It is important to recognise that in following this advice the value used for elastic modulus is in some ways a 'fudge'. It is modelling, in a single material property, the effects of creep, cracked section properties and elastic modulus.

## Non-linear FE deflection analysis

When using non-linear software, several analyses will often be required to obtain a final result. The software will carry out an iterative analysis

to determine an initial deflection; this will be based on initial, assumed, areas of reinforcement.

As discussed previously an important aspect to achieving a realistic estimate of deflection is to consider the loading history for the slab; once the slab has cracked (and hence has reduced in stiffness) this will affect the deflection throughout the life of the slab. This should be considered in the model.

The slab may not be cracked everywhere; rather it may be fully cracked in the zones of maximum moment, and in other places it may be only partially cracked or not cracked at all. An accurate assessment of deflection can only be made where the appropriate section properties are calculated for each element in the slab.

Software giving the most accurate deflection calculations will consider the shrinkage effects. Shrinkage depends on the water/cement ratio, relative humidity of the environment and the size and shape of the member. The effect of shrinkage in an asymmetrical reinforced section is to induce a curvature that can lead to significant deflection in shallow members.

Once the initial deflection has been determined, an assessment of the results should be carried out to decide whether the initial areas of reinforcement were appropriate. If not, they should be revised and the analysis re-run until there is convergence. It will be necessary to run the ULS model again with the correct reinforcement, because varying the area of reinforcement will alter the slab stiffness and hence the distribution of the moments (i.e. the stiffness at the supports will be reduced because of cracking and hence moment will be shed to other areas).

There will be different assumptions built into each piece of software and so it is very important that the engineer is fully aware of the assumptions and the effects they will have on the design.

## Software design tools

Engineering software is developing all the time, particularly the tools that are available to assist with design. Increasingly, software will produce a reinforcement layout based on the analysis and post-processing. The efficiency that can be achieved, especially when late changes to the design occur, is substantial. It is important for the user to thoroughly understand the software and the methods employed. The particular areas to consider are:

- How is deflection calculated?
- How is the additional reinforcement required for deflection control calculated and incorporated into the design?
- How are the design moments apportioned to column and middle strips and reinforcement layouts produced?
- Is a check on maximum moment transfer to the columns included or should this be carried out by hand?

## Summary

The use of FE analysis and design is certain to increase in the future. Currently it is a very useful method for slabs with irregular geometry, for dealing with openings in the slab and for estimating deflections. However, it is important to realise that the technique will not give lower design bending moments for regular grids. Having read this guide the practising engineer should be able to understand the following issues:

- How to correctly model concrete.
- How the software works and the difference between the types of software available.
- How to validate the software and the models analysed.
- How to interpret the results.

## References

- 1 BRITISH STANDARDS INSTITUTION. BS EN 1992–1–1: *Eurocode 2: Design of concrete structures. General rules and rules for buildings*. BSI, 2004.
- 2 BRITISH STANDARDS INSTITUTION. BS 8110–1: *The structural use of concrete – Code of practice for design and construction*. BSI, 1997.
- 3 GASPARINI, D.A. Contributions of C.A.P. Turner to development of reinforced concrete flat slabs 1905-1999. *Journal of Structural Engineering*, 2002, 128, No 10, pp 1243 - 1252.
- 4 LONDON COUNTY COUNCIL. *London Building Act*. LCC, 1930.
- 5 MELOSH, R. J. A stiffness matrix for the analysis of thin plates in bending. *Journal of the Aerospace Sciences*, Vol. 28, No. 1, Jan 1961. pp 34 – 42.
- 6 JONES, A E K & MORRISON, J. Flat slab design past present and future, *Structures and Buildings*, April 2005.
- 7 GOODCHILD, C H. *Economic concrete frame elements*. BCA, 1997.
- 8 THE CONCRETE SOCIETY. TR58: *Deflections in concrete slabs and beams*. The Concrete Society, 2005.
- 9 THE CONCRETE CENTRE. *Case studies on applying best practice to in-situ concrete frame buildings*. The Concrete Centre, 2004.
- 10 COLLINS, M R et al. The failure of an offshore platform, *Concrete International*, August 1997, pp 29 – 42.
- 11 GOODCHILD, C & WEBSTER, R. *Spreadsheets for concrete design to BS 8110 and Eurocode 2*, version 3. The Concrete Centre, due 2006.
- 12 PALLETT, P. *Guide to flat slab formwork and falsework*. Construct, 2003.
- 13 SCOTT, R H & WHITTLE, R. T. Moment redistribution effects in beams, *Magazine of Concrete Research*, 1 February 2005, pp 9 – 20.
- 14 THE CONCRETE SOCIETY. TR43: *Post-tensioned concrete floors design handbook* (Second edition). The Concrete Society, 2005.
- 15 WHITTLE, R. T. *Design of concrete flat slabs to BS 8110*, Report 110, revised edition. CIRIA, 1994.

## Design using FE analysis – synopsis

- 1 FE analysis will not reduce the slab thickness significantly compared with other methods of analysis.
- 2 Linear FE analysis is widely used and is more than adequate for many situations.
- 3 Non-linear FE analysis is more sophisticated and can be used to estimate deflection.
- 4 It is important to carry out hand checks prior to FE analysis.
- 5 There should be sufficient nodes in the model to obtain accurate results, but it is possible to have too many nodes, especially at supports where the peak moments are accentuated. Elements should be smaller than span/10 or 1000 mm.
- 6 The element shapes should be well-conditioned. An aspect ratio of less than 2 to 1 is appropriate.
- 7 The column stiffness should be modelled, i.e. 'pinned' supports are not recommended.
- 8 The area of the column should be modelled i.e. point supports are not recommended.
- 9 Pattern loading should be considered, but 'chequerboard' loading is not appropriate.
- 10 Validate your results by considering:
  - Element size in critical locations.
  - Is there static equilibrium?
  - Do hand checks give similar results?
  - Do the graphical results look right?
  - Are the results in line with those for similar structures?
- 11 Understand the software. Ask for a summary guide from software suppliers.
- 12 Ensure that twisting moments are considered in the design.
- 13 Do not design the reinforcement for the peak moments; take an average moment over an appropriate width.
- 14 Even the most sophisticated deflection analysis will be accurate only to +15% to –30%.
- 15 With linear FE analysis use an elastic modulus value modified to take account of creep and slab stiffness in order to check deflections are within limiting criteria.
- 16 If using non-linear analysis to obtain deflection estimates, it is important to critically appraise the software and understand its limitations.

## Acknowledgements

The content and illustrations have come from many sources. The help and advice received from many individuals are gratefully acknowledged. Special thanks are due to the following for their time and effort in commenting and providing technical guidance in the development of this publication:

Kenny Arnott	CSC (UK) Ltd
Allan Bommer	RAM International
Tony Jones	Arup
Des Mairs	Whitbybird
John Morrison	Buro Happold
Robert Vollum	Imperial College, London
Rod Webster	Concrete Innovation & Design

For more information on Finite element analysis, and for assistance relating to the design, use and performance of concrete contact the free National Helpline on:

**0700 4 500 500** or **0700 4 CONCRETE**  
[helpline@concretecentre.com](mailto:helpline@concretecentre.com)

### Published by The Concrete Centre

Riverside House, 4 Meadows Business Park,  
 Station Approach, Blackwater, Camberley,  
 Surrey GU17 9AB

**Tel:** +44 (0)1276 606800

**Fax:** +44 (0)1276 606801

[www.concretecentre.com](http://www.concretecentre.com)



The Concrete Centre™