

Sección
V. 301-302-303
Escala 1/25

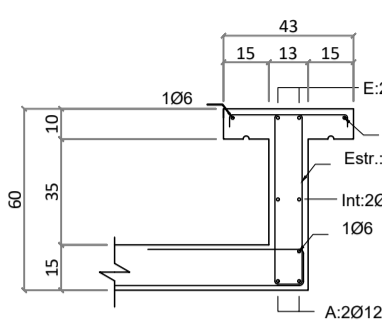

V. 304
Escala 1/50

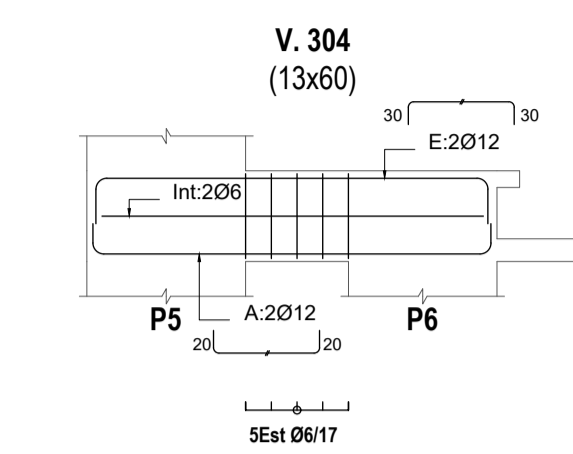

Sección
V. 304
Escala 1/25

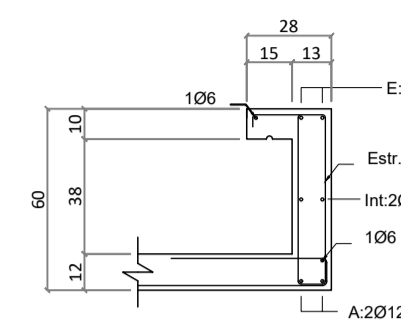

V. 305-306
Escala 1/50

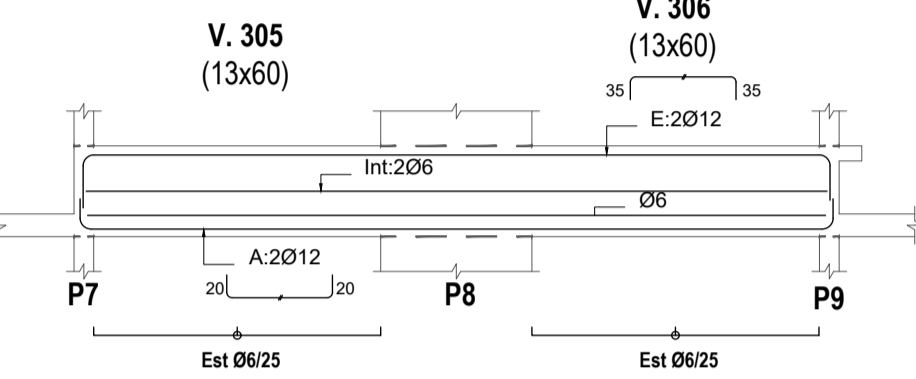

Sección
V. 305-306
Escala 1/25

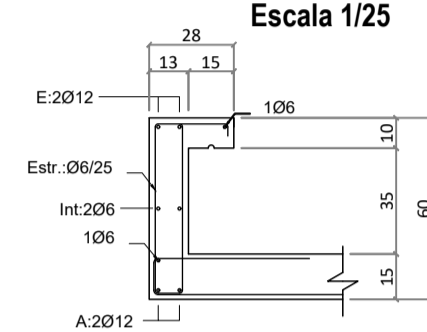

V. 307
Escala 1/50

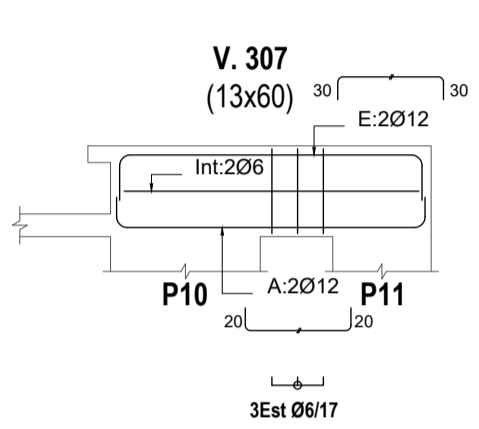

Sección
V. 307
Escala 1/25

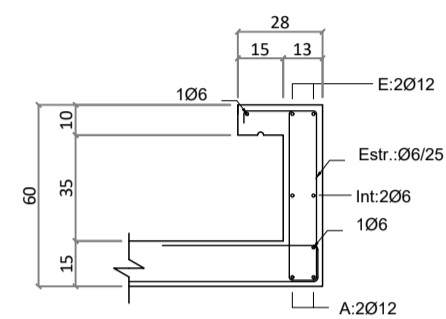

V. 308
Escala 1/50

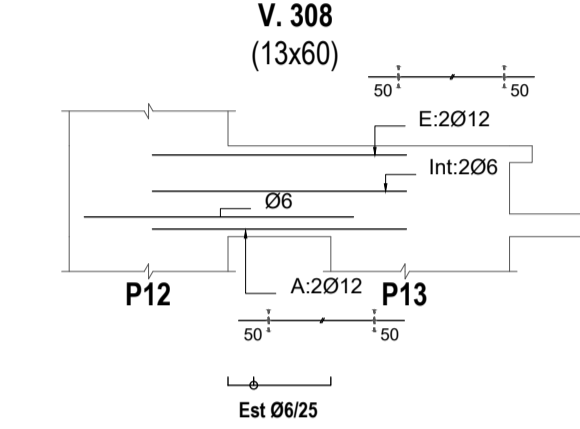

Sección
V. 308
Escala 1/25

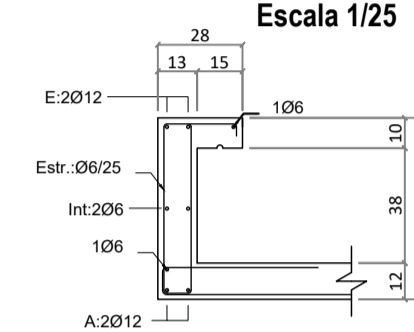

V. 310
Escala 1/50

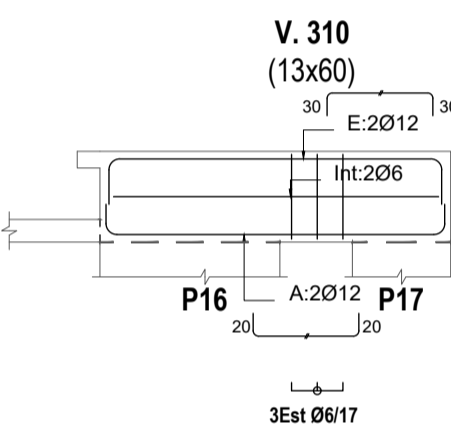

Sección
V. 310
Escala 1/25

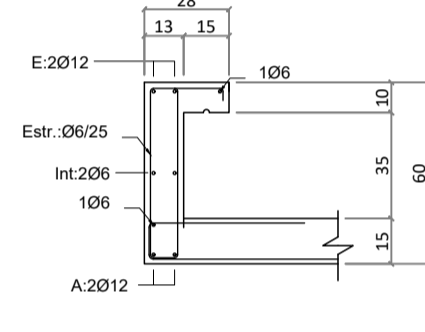

V. 311-312-313
Escala 1/50

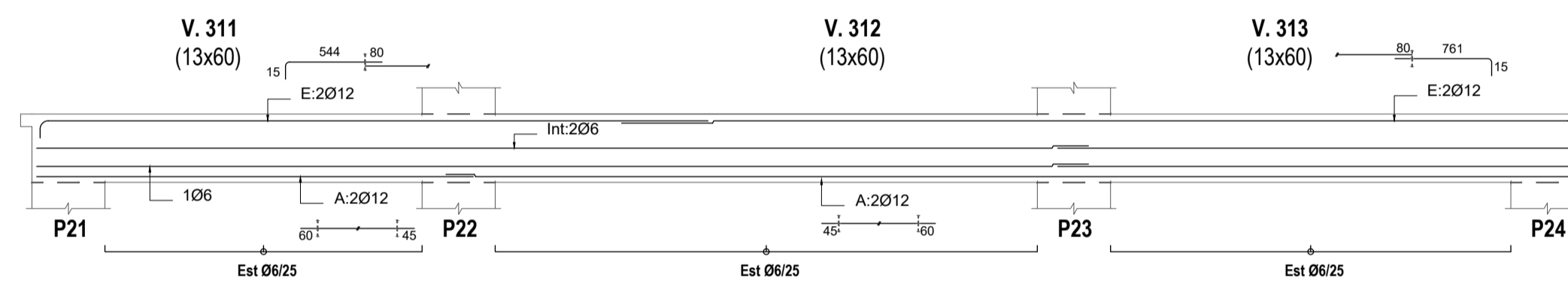

Sección
V. 311-312-313
Escala 1/25

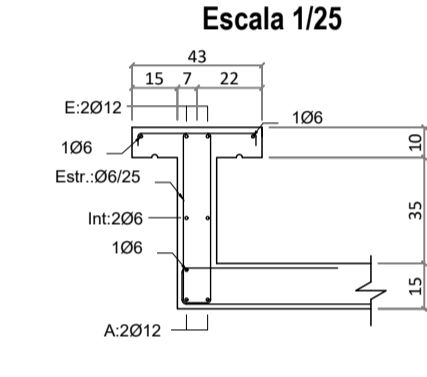

V. 351
Escala 1/50



Sección
V. 351
Escala 1/25

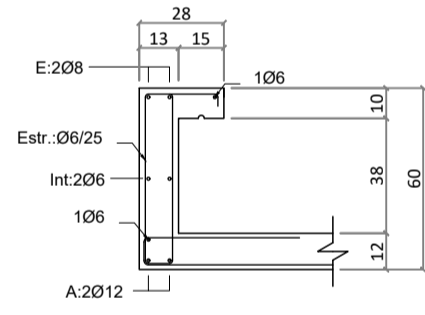

V. 352
Escala 1/50



Sección
V. 352
Escala 1/25

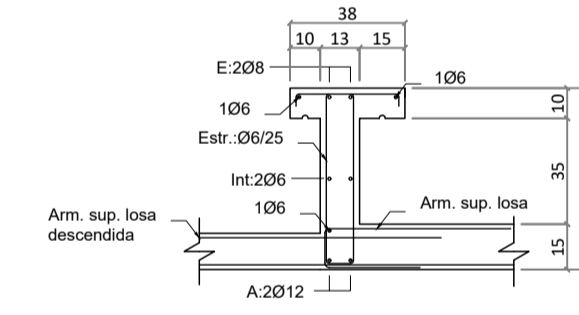

V. 353
Escala 1/50

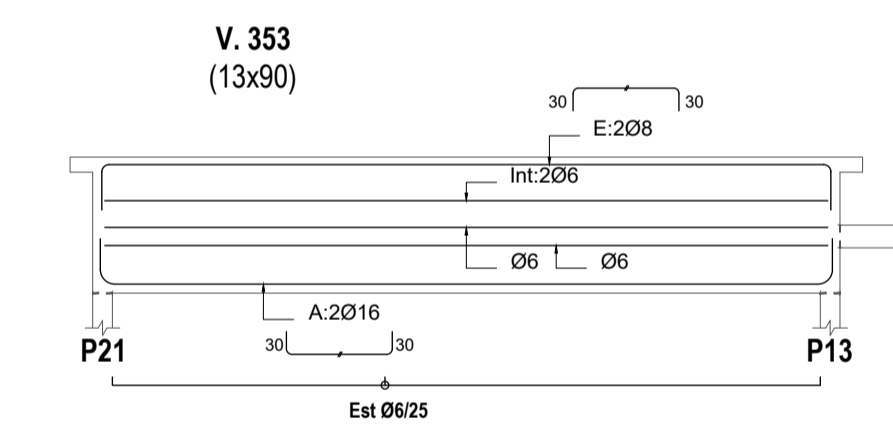

V. 354
Escala 1/50

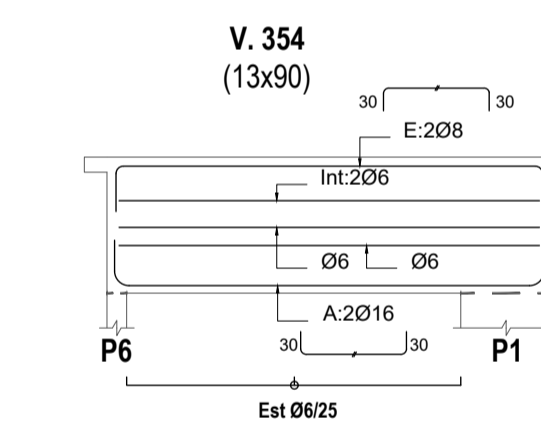

Sección
V. 353-354
Escala 1/25

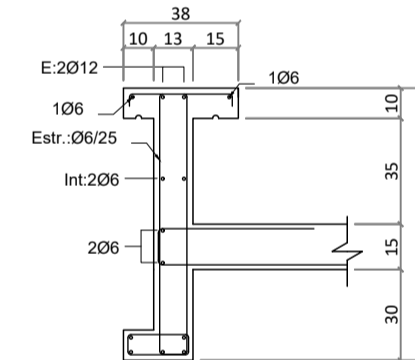

V. 356
Escala 1/50

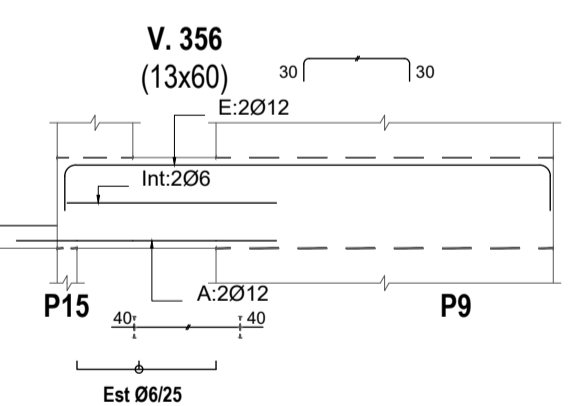

Sección
V. 356
Escala 1/25

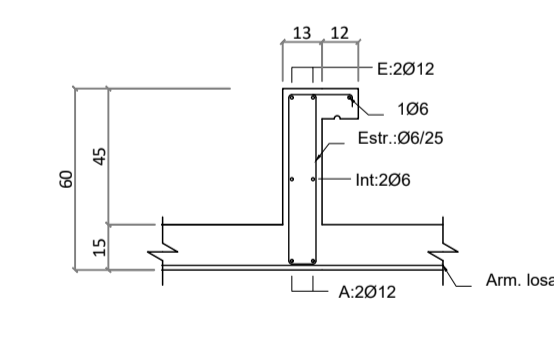

V. 357
Escala 1/50

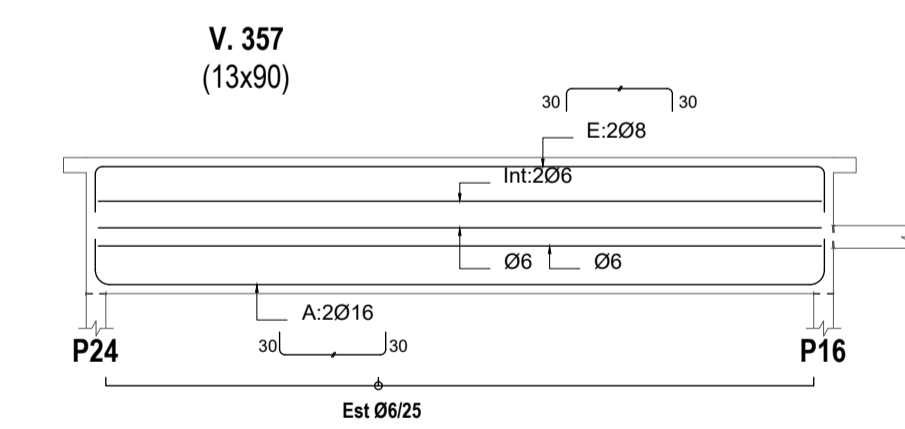

V. 358
Escala 1/50

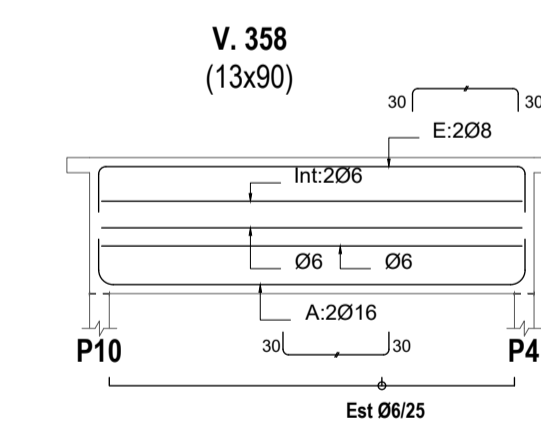

Sección
V. 357-358
Escala 1/25

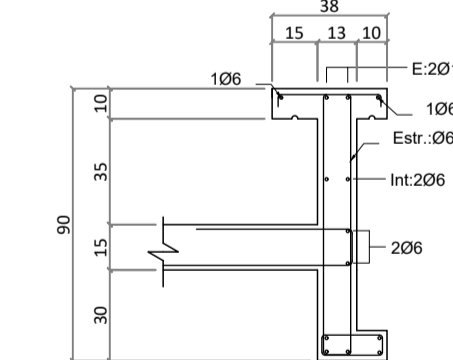

V. 359
Escala 1/50

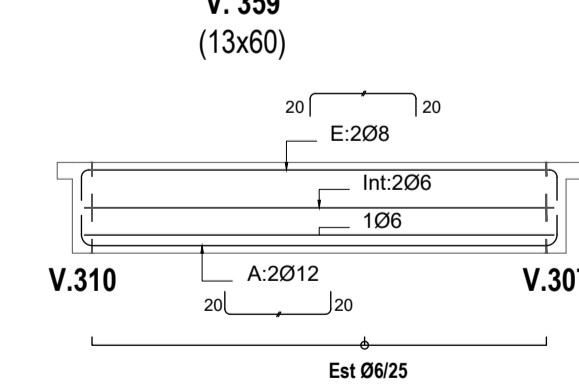

Sección
V. 359
Escala 1/25

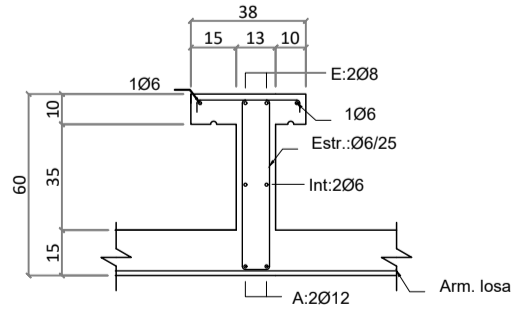

V. 360
Escala 1/50

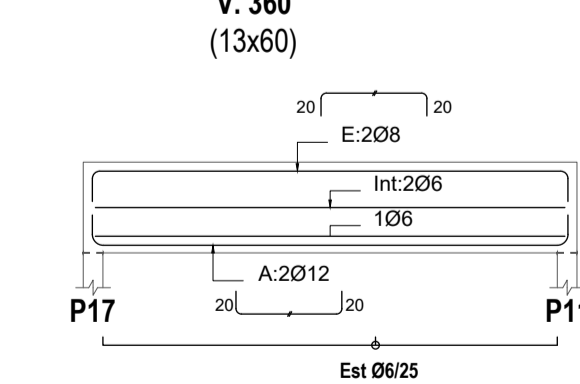

Sección
V. 360
Escala 1/25

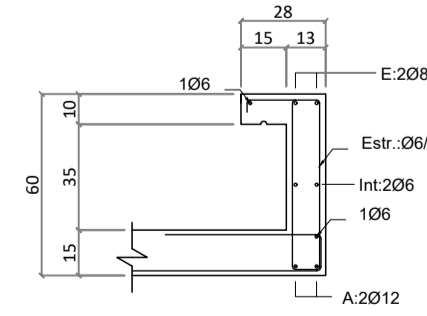

REFERENCIAS

- Pilar que continua
- Pilar que muere
- Pilar que nace
- Losa descendida
- Niveles
- CSL Cota Superior Losa
- CSV Cota Superior Viga
- CSC Cota Superior Cabezal
- CSP Cota Superior Pilote

MATERIALES

HORMIGÓN: C25, resistencia característica de 250 kg/cm² o los 28 días según UNIT 972

ACERO: Barras conformadas ADN500, según UNIT 843 y UNIT 968

RECURRIMIENTOS

VIGAS: 20 mm
 PILARES: 20 mm
 LOSAS: 20 mm
 FUNDACIONES: 40 mm

EMPALMES DE ARMADURA

Es la indicada en tabla según UNIT 1050-2005

Ø [mm]	6	8	10	12	16	20	25
VIGAS Y LOSAS	45	55	70	85	115	165	250
PILARES	30	40	50	60	80	120	185

DOBLADO DE ARMADURA

ESTRIBOS Y PATILLAS GENERALES: Diámetro del mandril 3.5φ

ACIARACIONES: Diámetro del mandril 12φ

Todas las dimensiones y niveles en centímetros.

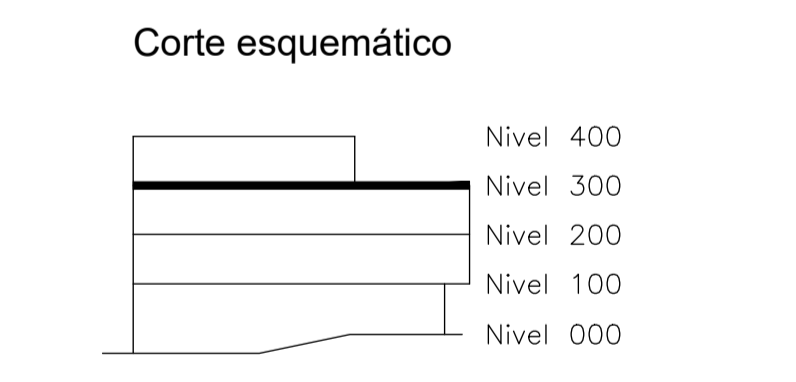
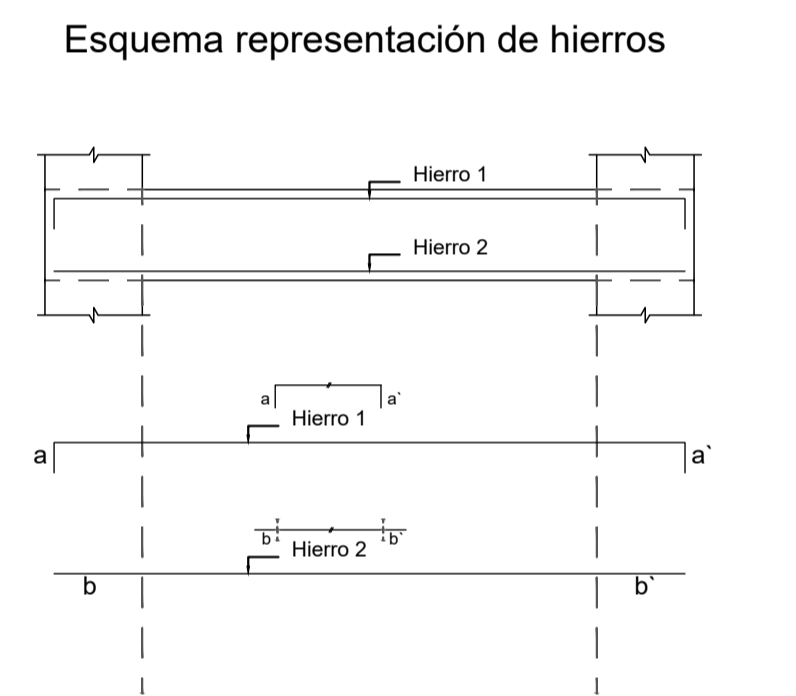

FACULTAD DE INGENIERIA

OBRA: PROYECTO 1 - 2015

PLANO: VIGAS INDICE 300

PROFESORES: Rodríguez - Dieste - Pertusso

GRUPO: Barbier - Colman - Ferreira

FECHA: 5 febrero 2017

ESCALA: 1:50

FORMATO: A1

PLANO N°: **E3.7**