

© SMPTE 2005 – All rights reserved

SMPTE Standard for Television

Date: 2005-12 08

SMPTE 259M

Revision of 259M - 1997

SMPTE Technology Committee N26 on File Management & Networking Technology
TP Rev 1

SDTV¹ Digital Signal/Data - Serial Digital Interface

Note 1 SDTV - Standard Definition Television

Warning

This document is not a SMPTE Standard. It is distributed for review and comment. It is subject to change without notice and may not be referred to as a SMPTE Standard. Recipients of this document are invited to submit, with their comments, notification of any relevant patent rights of which they are aware and to provide supporting documentation. Distribution does not constitute publication.

Contents		Page
	Foreword	2
	Introduction	2
1	Scope	3
2	Normative References	3
3	Signal Levels and Specifications	3
4	Connector and cable Types	5
5	Channel coding	5
6	Transmission order	5
7	Component 4:2:2 signals	5
8	Levels of operation	7
	Annex A (Normative) Composite NTSC $4f_{sc}$ signals	8
	Annex B (Informative) Composite PAL $4f_{sc}$ signals	10
	Annex C (informative) Generator polynomial implementations	13
	Annex D (informative) Timing jitter specification	14
	Annex E (informative) Waveform measurement method	14
	Annex F (Informative) Optional Ancillary Data $4f_{sc}$ PAL	14
	Annex G (informative) 259M Road Map	15
	Bibliography	16

Foreword

SMPTE (the Society of Motion Picture and Television Engineers) is an internationally recognized standard developing organization. Headquartered and incorporated in the United States of America, SMPTE has members in over 80 countries on six continents. SMPTE's Engineering Documents, including Standards, Recommended Practices and Engineering Guidelines, are prepared by SMPTE's Technology Committees.

Participation in these Committees is open to all with a bona fide interest in their work. SMPTE cooperates closely with other standards-developing organizations, including ISO, IEC and ITU.

SMPTE Engineering Documents are drafted in accordance with the rules given in Part XIII of its Administrative practices.

Introduction

This version of SMPTE 259M reflects the industry usage that has evolved over the past years. The original intent of SMPTE 259M was to provide a serial digital connection between equipment replacing the parallel interface. At that time, uncompressed digital video was considered to be the only payload. This standard has evolved to also carry formatted data within the defined payload areas.

Formatting of the data, and the types of data to be carried are defined by other SMPTE standards (see Annex G for a document road map).. Informative Annex F includes a reference to SMPTE 291M; this reference is made, as the IEC reference part of informative annex B does not include a definition of ancillary data structure

1 Scope-

This standard describes a 10 bit serial digital interface operating at 143/270/360Mb/s. The serial interface may carry uncompressed SDTV signals, or data. This standard has application in the television studio over lengths of coaxial cable where the signal loss does not exceed an amount specified by the receiver manufacturer. Typical loss amounts may be in the range of 20 dB to 30 dB at one half clock frequency with appropriate receiver equalization. Receivers designed to work with lesser signal attenuation are acceptable, but are not recommend for new designs.

2 Normative references-

The following standards contain provisions, which, through reference in this text, constitute provisions of this standard. At the time of publication, the editions indicated were valid. All standards are subject to revision, and parties to agreements based on this standard are encouraged to investigate the possibility of applying the most recent edition of the standards indicated below.

SMPTE 125M-1995, Television ---- Component Video Signal 4:2:2 ---- Bit-Parallel Digital Interface.

SMPTE 267M- 1995 Television---Bit-Parallel Digital Interface ---- Component

Video Signal 4:2:2 16x 9 Aspect Ratio.

SMPTE 244M-2004, Television ---- System M/NTSC Composite Video Signals - Bit-Parallel Digital Interface.

SMPTE RP 184-1996, Specification of Jitter in Bit-Serial Digital Systems.

IEC 60169-8, Sections A.2 and A.3, "Amendment 2, Radio-frequency connectors Part 8: R.F. coaxial connectors with inner diameter of outer conductor 6,5 mm (0,256 in) with bayonet lock – Characteristics impedance 50 ohms (type BNC)"¹

3 Signal levels and specifications-

The specifications in this clause are defined for measurement of the serial output of a source, "a generator", derived from a parallel domain whose timing ensures the jitter specifications defined in § 3.5. Specifications at the output of equipment located at other places in an all-serial digital chain are not addressed by this standard. Clock frequency refers to the serial clock and is equal to the bit rate for each television system.

3.1 The output of the generator shall be measured across a 75-ohm resistive load connected through a short coaxial cable,(approx 1 meter). Figure 1 depicts the measurement dimensions for amplitude, risetime, and overshoot (see annex E for the preferred measurement method for these parameters).

3.1.1 The generator shall have an unbalanced output circuit with a source impedance of 75 ohm and a return loss of at least 15 dB over a frequency range from 5 MHz to the clock frequency of the signal being transmitted.

3.1.2 The peak-to-peak signal amplitude shall be 800 mV \pm 10%.

3.2 The DC offset, as defined by the mid-amplitude point of the signal, shall be nominally 0.0 V \pm 0.5 V.

3.3 The rise and fall times, determined between the 20% and 80% amplitude points, shall be no less than 0.4 ns, no greater than 1.50 ns, and shall not differ by more than 0.5 ns.

3.4 Overshoot of the rising and falling edges of the waveform shall not exceed 10% of the amplitude.

¹ Please note that the title of this normative reference may be misleading. This standard requires the use of the 75 ohm connector defined in this reference.

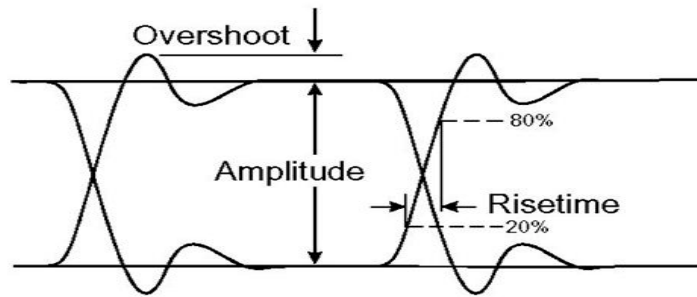

Figure 1 -- Waveform measurement dimensions

3.5 The jitter in the timing of the transitions of the data signal shall be measured in accordance with SMPTE RP 184. Measurement parameters are defined in SMPTE RP 184 and shall have the following values for compliance with this standard:

<i>Timing jitter lower band edge</i>	10 Hz	<i>f1</i>
<i>Alignment jitter lower band edge</i>	1 kHz	<i>f3</i>
<i>Upper band edge</i>	>1/10 clock rate	<i>f4</i>
<i>Timing jitter (note 1)</i>	0.2 UI p-p	<i>A1</i>
<i>Alignment jitter (UI = unit interval)</i>	0.2 UI p-p	<i>A2</i>
<i>Color bar test signal</i>	525 Lines	75/7.5/75/7.5
<i>Such as ITU-R BT 471-1 or similar (note 2)</i>	625 Lines	100/0/75/0
<i>Serial clock divider (note 3)</i>	≠10	<i>n</i>

Informative NOTES-

1 Designers are cautioned that the clock in parallel signals conforming to interconnection standards, such as SMPTE 125M, may contain jitter up to 6 ns p-p. Deriving the serial signal directly from the unfiltered parallel clock could result in excessive serial signal jitter (see annex D for further information on timing jitter).

2 Color bars are chosen as a non-stressing test signal for jitter measurements. Use of a stressing signal with long runs of zeros may give misleading results

3 Use of a serial clock divider value of 10 is acceptable; however, it may mask word-correlated jitter components. The divider value should be stated in conjunction with jitter specifications.

3.6 The input to the serial receiver signal shall present an impedance of 75 ohm with a return loss of at least 15 dB over a frequency range from 5 MHz to the clock frequency of the signal being transmitted.

4 Connector and cable types

4.1 The male and female connectors shall be 75ohm BNC as defined in IEC 60169-8, Sections A.2 and A.3

4.2 Application of this standard does not require a particular type of coaxial cable. It is necessary for the frequency response of the coaxial cable loss, in decibels, to be approximately proportional to $1/\sqrt{f}$ from 1MHz to the clock frequency of the signal being transmitted to ensure correct operation of automatic cable equalizers over moderate to maximum lengths.

5 Channel coding

5.1 The channel coding shall be scrambled NRZI.

5.2 The generator polynomial for the scrambled NRZ shall be $G_1(X) = X^9 + X^4 + 1$. The polarity-free scrambled NRZI sequence shall be produced by $G_2(X) = X + 1$. The input signal to the scrambler shall be positive logic (the highest voltage represents data 1 and the lowest voltage data 0) [see annex C].

5.3 Data word length shall be 10 bits.

NOTE -- *Because some legacy parallel interfaces may carry only 8 bits of data, values in the range $3FC_n$ to $3FF_n$ must be treated as equivalent to $3FF_n$ for the purpose of detecting ancillary data flags or other identifying flags using those values.*

6 Transmission order

The LSB of each data word shall be transmitted first.

7 Component 4:2:2 signals

7.1 The input source for generating a serial 4:2:2 video data stream shall be as defined by SMPTE 125M, and SMPTE 267M. Ancillary data if present shall be passed by the serial interface transparently.

Informative Note- *Ancillary data may be added to the serial bit stream by external devices.*

7.1.1 Because some parallel component digital interfaces may carry only 8 bits of video data, it is necessary for the data serializer to identify this condition and to add the necessary data to convert the 8-bit signal to a 10-bit representation. The EAV and SAV of the 8-bit signals should be converted in the following manner:

8 bit	10 bit
FF	3FF
00	000
00	000
PQ	XYZ (= PQ data left shifted twice with subordinate bits set to zero)

7.2 The bit rate for the resulting serial data stream shall be nominally 270 Mb/s for 13.5-MHz luma sampling and 360 Mb/s for 18-MHz luma sampling

8 Levels of operation- informative

To define the level of support for this standard, manufacturers are encouraged to indicate in commercial publications, bit rate (s) supported,

Level A -- 143 Mb/s,
 Level B -- 177 Mb/s,
 Level C -- 270 Mb/s,
 Level D -- 360 Mb/s,

Examples of compliance nomenclature-

A SMPTE D-2 VTR accepting only composite digital NTSC would be said to conform to SMPTE 259M-A.

A multistandard routing switcher with a maximum bit rate of 270 Mb/s would be said to conform to SMPTE 259M-ABC.

Annex A (Normative) Composite NTSC $4f_{sc}$ signals

Although it is not anticipated that use of this annex will expand greatly, there continues to be many implementations still in use, as such, this is a normative annex.

A1.1 Input source

The input source for generating a serial $4f_{sc}$ composite video data stream shall conform to SMPTE 244M. Ancillary data may be part of the SMPTE 244M interface, or may be added by external devices.

A1.1.1 Because some SMPTE 244M interfaces may only carry 8 bits of video data, it is necessary for the data serializer to identify this condition and to add the necessary data to convert the 8-bit signal to a 10-bit representation.

A1.2 Bit rate

The bit rate for the resulting data stream shall be nominally 143 Mb/s.

A1.3 Signal processing

Signal processing of the input signal is necessary to provide timing and synchronizing information in the serial digital domain. This information is designated TRS-ID, timing reference signal and line number identification.

A1.3.1 The TRS and line number ID shall be present only following the sync leading edge that identifies a horizontal rate transition. (see Fig. A1 and A2).

A1.3.2 The TRS signal shall consist of four words located at word number addresses 790, 791, 792, 793. Corresponding word values are 3FF, 000, 000, 000.

A1.3.3 Line number ID shall be one word. The line number word-number address shall be 794 with the following values:

b2	b1	b0		
0	0	0	Line	1 — 263 Field 1
0	0	1	Line	264 - 525 Field 2
0	1	0	Line	1 - 263 Field 3
0	1	1	Line	264 - 525 Field 4
b7 (MSB)	b6	b5	b4	b3 (LSB)

The possible values of X1 are restricted by the use of bits b7-b3 and indicate the following:

X1 = 0	Not used.
1 < X1 < 30	X1 indicates the line number of each field (lines 1 - 30 in odd fields, lines 264 - 293 in even fields).
X1 = 31	To indicate line number 31 and up of each odd field and line number 294 and up on each even field.
$X1 = 16 (b7) + 8 (b6) + 4 (b5) + 2 (b4) + 1 (b3)$.	

b8 is even parity for b7 through b0

$$b9 = \overline{b8}$$

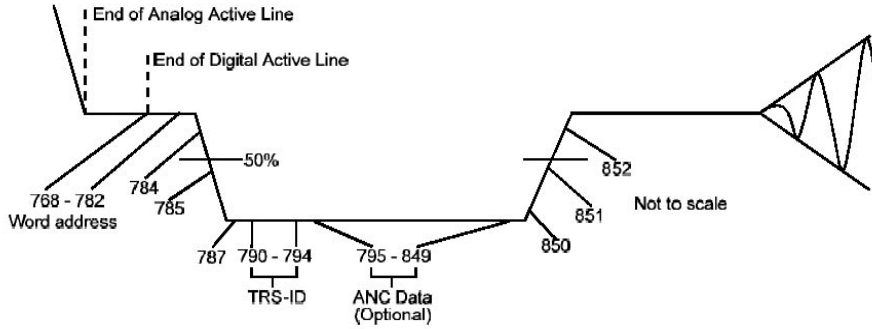

Figure A 1 -- NTSC horizontal sync details

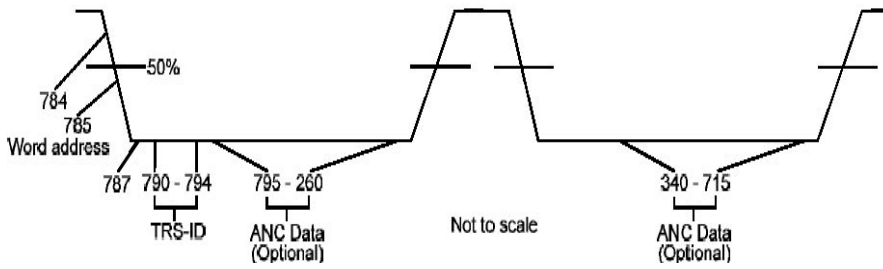

Figure A 2 -- NTSC vertical sync details

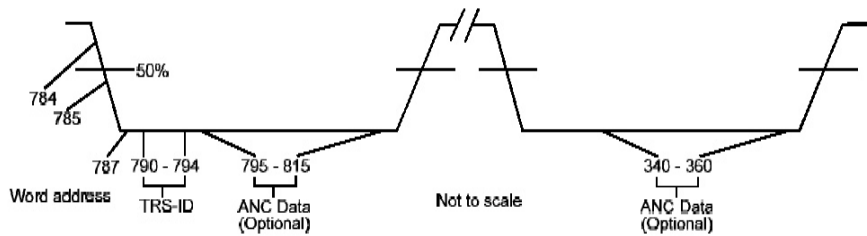

Figure A3 -- NTSC equalizing pulse details

Annex B (Informative) Composite PAL $4f_{sc}$ signals

Details of $4f_{sc}$ composite PAL data formatting is provided for systems designers. It is not expected that further use of this mapping will be implemented. Some legacy installations may still be in service.

B1.1 Input source

The input source for generating a serial $4f_{sc}$ composite video data stream shall conform to IEC 61179. Ancillary data may part of the IEC 61179 interface, or may be added by external devices (see informative annex F)

B1.1.1 Because some IEC 61179 interfaces may carry only 8 bits of video data, it is necessary for the data serializer to identify this condition and to add the necessary data to convert the 8-bit signal to a 10-bit representation.

B1.2 Bit rate

The bit rate for the resulting serial data stream shall be nominally 177.3 Mb/s.

B1.3 Signal processing

Signal processing of the input signal is necessary to provide timing and synchronizing information in the serial digital domain. This information is designated TRS-ID, timing reference signal and line number identification.

B1.3.1 The TRS and line number ID shall be present only following the sync leading edge that identifies a horizontal rate transition. (see Fig. B1 and B2)

B1.3.2 The TRS signal shall consist of four words located at word number addresses 967, 968, 969, 970. Corresponding word values are 3FF, 000, 000, 000.

B1.3.3 Reset of the TRS position relative to the H-sync edge shall take place once per field on only one of lines 625 - 4 and one of lines 313 - 317. Reset is necessary due to the non-integer number of samples per line. Therefore, from a sample numbering standpoint, all lines will have 1135 samples except the two lines used for reset which will have 1137 samples.

The additional samples will be numbers 1135 and 1136 just prior to the first active picture sample 000. This does not affect the continuous signal concept where all but two lines in a field have 1135 samples and the other two have 1136. (The line numbers with 1136 samples are a function of Sc/H phase and the criteria for determining which samples fall in which lines.)

Designers should note that sample locations in figures B1, B2, and B3 represent the first line following the above-mentioned reset. Subsequent nearby low-line numbers will be similar, but the samples are slightly earlier on each line due to the non-integer number of samples per line.

Initial determination of the position of TRS should, therefore, be done on the line following sample numbering reset or a nearby subsequent line.

Considering the 0 Sc/H phase requirement of IEC 61179 and the sample

numbering system described above, the TRS location is known and starts exactly with sample 967 on each line, but its time from the leading edge of sync varies due to the non-integer number of samples per line.

B1.3.4 Line number ID shall be one word. The line number word-number address shall be 971 with the following values:

b2	b1	b0			
0	0	0	Line	1 – 313	Field 1
0	0	1	Line	314 - 625	Field 2
0	1	0	Line	1 - 313	Field 3
0	1	1	Line	314 - 625	Field 4
1	0	0	Line	1 - 313	Field 5
1	0	1	Line	314 – 625	Field 6
1	1	0	Line	1 – 313	Field 7
1	1	1	Line	314 – 625	Field 8

b7	b6	b5	b4	b3
(MSB)				(LSB)

The possible values of X1 are restricted by the use of bits b7-b3 and indicate the following:

- X1 = 0 Not used.
- 1 < X1 < 30 X1 indicates the line number of each field (lines 1 - 30 in odd fields, lines 314 - 343 in even fields).
- X1 = 31 To indicate line number 31 and up of each odd field, and line number 344 and up on each even field.

$X1 = 16 (b7) + 8 (b6) + 4 (b5) + 2 (b4) + 1 (b3)$.
 b8 is even parity for b7 through b0.

$b9 = \overline{b8}$

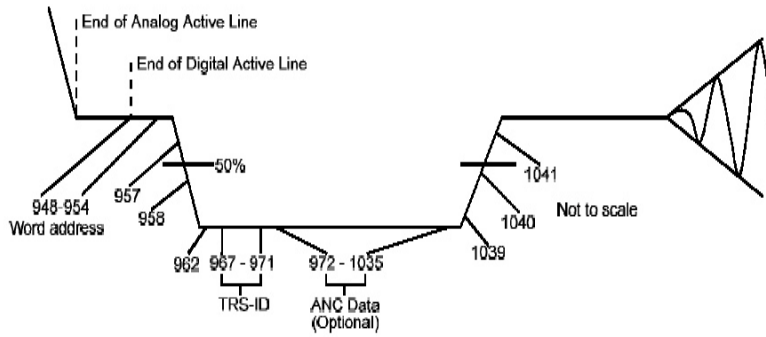

Figure B1 -- PAL horizontal sync details

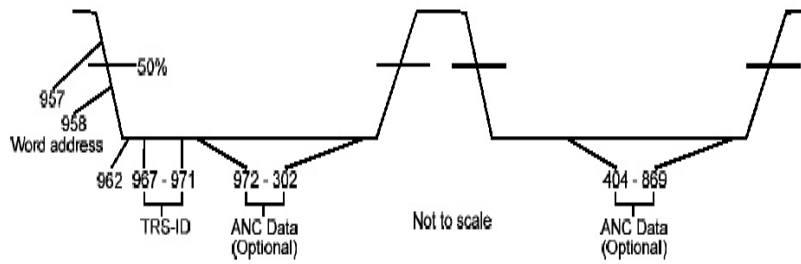

Figure B2-- PAL vertical sync details

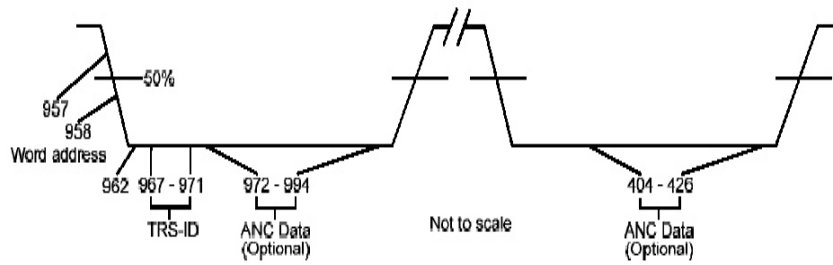

Figure B3 -- PAL equalizing pulse details

Annex C (informative) Generator polynomial implementations-

Possible generator polynomial implementations are given in figures C.1 and C.2.

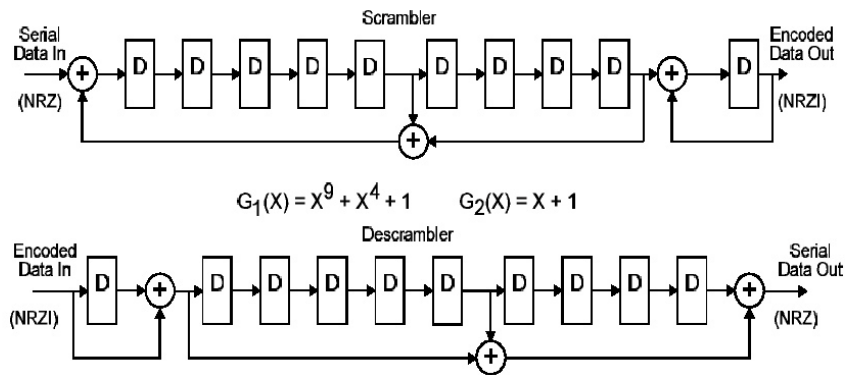

Figure C.1 -- Possible generator polynomial -- Method 1

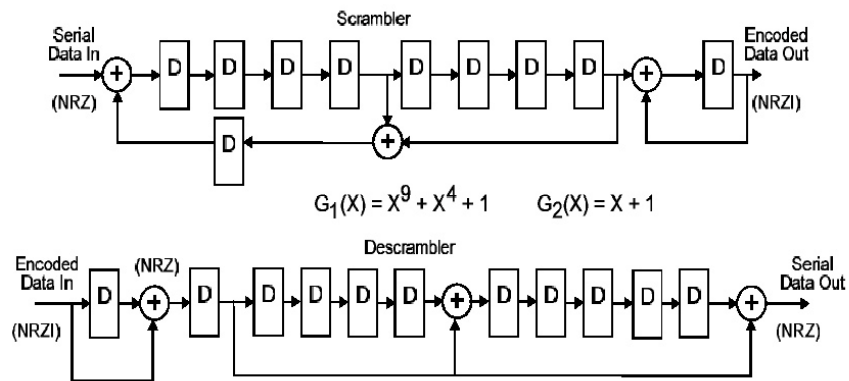

Figure C.2 -- Possible generator polynomial -- Method 2

Annex D (informative) Timing jitter specification

Low-frequency jitter in the range of 10 Hz to 1 kHz is indicated by the difference between timing jitter (A1) and alignment jitter (A2) measurements. Although purely digital systems will operate correctly with significant amounts of low-frequency jitter, this standard (§3.5) specifies a tight tolerance for timing jitter to ensure operation in mixed digital/analog systems. Methods do exist for handling larger amounts of low-frequency jitter in such systems.

Annex E (informative) Waveform measurement method

The preferred method for measuring serial digital waveform amplitude, risetime, and overshoot is using a 1-GHz bandwidth oscilloscope. Input impedance of the oscilloscope should be 75 ohm with a return loss greater than 20 dB to 400 MHz. Measurements should be made using a 2-m length of coaxial cable between the transmitter and oscilloscope with no more than 0.15 dB/m loss at 135 MHz.

Annex F (Informative) Optional Ancillary Data $4f_{sc}$ PAL

This annex is intended to provide information for the insertion of optional ancillary data into an IEC 61179 interface.,

F 1 Ancillary Data- optional

Ancillary data, if present, shall comply with the following rules

F1.1 Ancillary data shall be formatted according to SMPTE 291M.

F1.2 Certain word numbers within the ancillary data space are reserved for error detection data format. See SMPTE RP 165

F1.4 There may be multiple ANC data flags in the allocated ancillary data space

F1.3 Ancillary data may be present within the following word number boundaries:

972 – 1035 for horizontal sync period

972 – 994 for equalizing pulse period
404 - 426

972 – 302 for vertical sync period
404 - 869

Annex G (Informative) SMPTE 259 Document road map

Referenced documents

- SMPTE 125 - interface/source
- SMPTE 244 – NTSC parallel interface
- SMPTE 267- Interface/source
- RP 184 - jitter
- IEC 60169-8 – connector

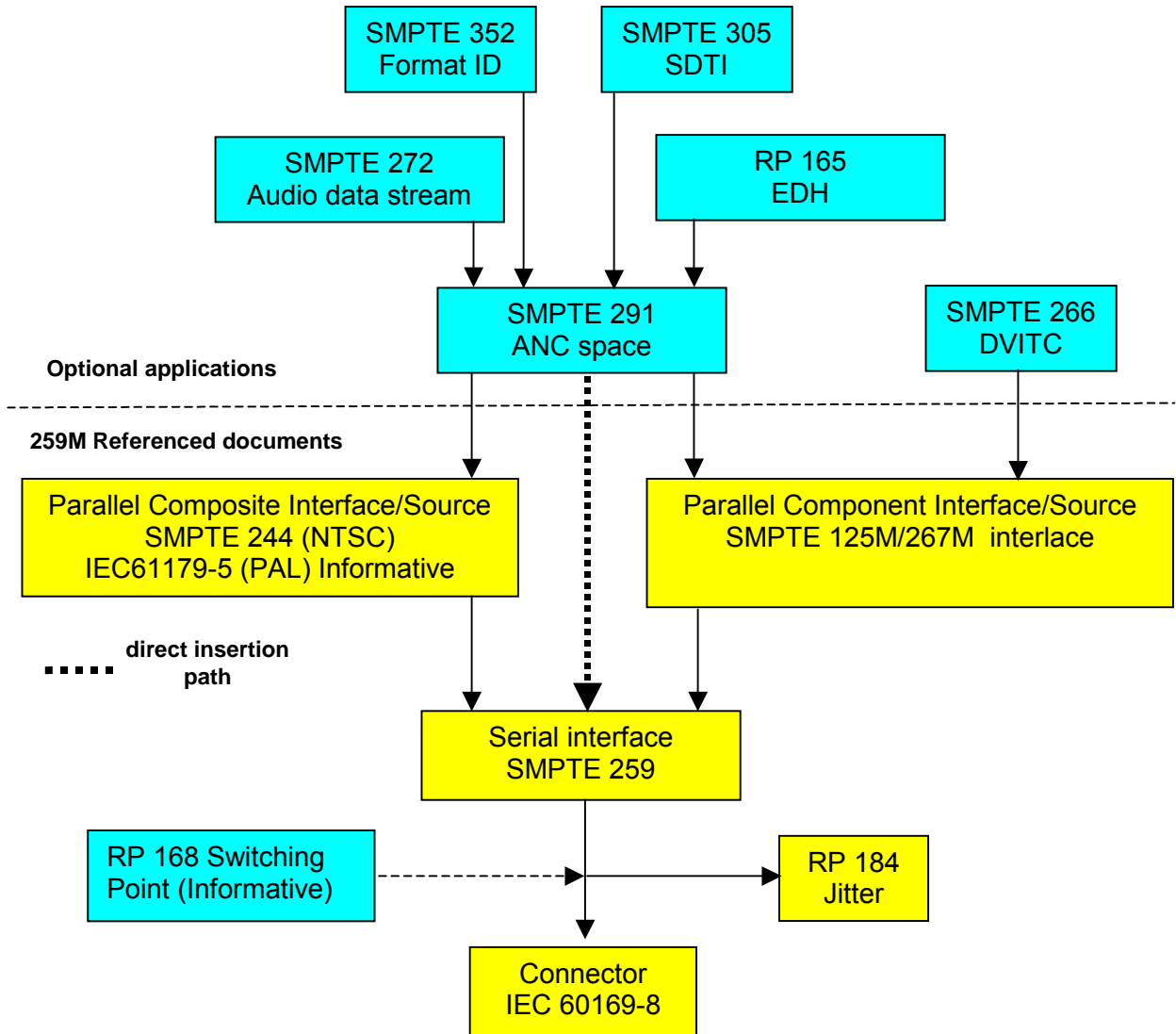

Bibliography

ITU-R BT 471-1 Nomenclature and Description of colour bar Signals

SMPTE 291M-1996, Television ---- Ancillary Data Packet and Space Formatting

SMPTE RP 165-2003, Error Detection Checkwords and Status Flags for Use in Bit-Serial Digital Interfaces for Television

SMPTE RP 192-1996, Jitter Measurement Procedures in Bit-Serial Digital Interfaces

ITU-R BT.1700 Characteristics of video signals for conventional analogue televisions systems

SMPTE RP 178-2003 Serial Digital interface Checkfield for 10 Bit 4:2:2 Component and 4fsc Composite Digital Signals

IEC 61179 (1993), Helical-Scan Digital Composite Video Cassette Recording System Using 19 mm Magnetic Tape, Format D2 (NTSC, PAL, PAL-M), Section 5, Video Interface

IEEE Std 1521 Trial-Use Standard for Measurement of Video Jitter and Wander

Copyright notice

Copyright 2002 THE SOCIETY OF MOTION PICTURE AND TELEVISION ENGINEERS

595 W. Hartsdale Ave.
White Plains, NY 10607
+1 914 761 1100
Fax +1 914 xxx xxxx
E-mail eng@smpte.org
Web www.smpte.org