

# Redes de sensores inalámbricos (RSI)

## Introducción a las RSI

Leonardo Steinfeld

Inst. de Ingeniería Eléctrica, Fac. de Ingeniería  
Universidad de la República (Uruguay)



Co-funded by the  
Erasmus+ Programme  
of the European Union



FACULTAD DE  
INGENIERÍA



UNIVERSIDAD  
DE LA REPÚBLICA  
URUGUAY

Disclaimer: The European Commission support for the production of this website does not constitute an endorsement of the contents which reflects the views only of the authors, and the Commission cannot be held responsible for any use which may be made of the information contained therein.

# Objetivos / Agenda

- Objetivos
  - Introducir a los principales conceptos de RSI
- Agenda
  - Conceptos y definiciones de RSI
  - Elementos: nodos (nodo sensor, mote, mota, etc.)
  - Tecnologías de comunicaciones (opciones)

# RSI: introducción

- ¿Qué son las redes de sensores inalámbricos?
  - sensores (también actuadores)
  - comunicación inalámbrica
  - redes: forman una red

# RSI: otra aproximación...

- Twister (1996)

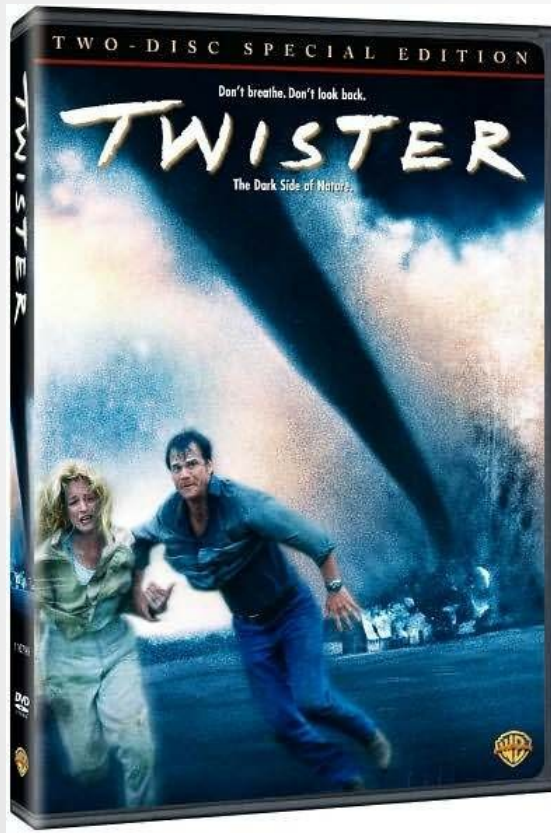

- Black Mirror (S03E06):  
Hated in the Nation (2016)



# RSI: características & desafíos

- Gran cantidad de sensores (decenas, cientos, ... miles)
  - múltiples consecuencias: costo, mantenimiento, etc.
- Características
  - Sistemas embebidos en red
  - Bajo consumo
  - Tolerante a fallos

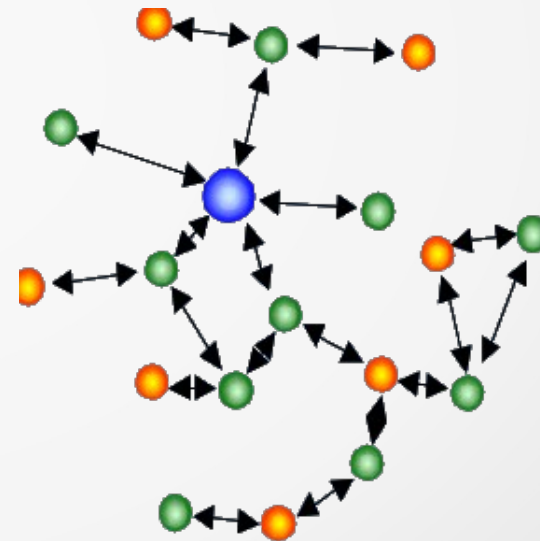

# RSI: características & desafíos

- Red de comunicación
  - topología: estrella o malla
  - auto-organizadas
  - autónomas

Mesh Topology

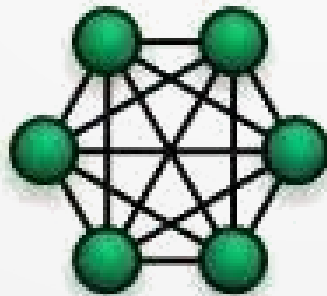

Star Topology

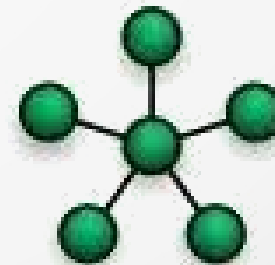

# RSI: relación con IoT & LNN

- IoT según ITU-T
  - “A global infrastructure for the information society, enabling advanced services by interconnecting (physical and virtual) things based on existing and evolving interoperable information and communication technologies.” (“Overview of the Internet of things”, ITU-T (Y.4000/Y.2060) , 2012)
- IoT según IETF (LLN: Low power Lossy Network)
  - “Networks [...] composed of many embedded devices with limited power, memory, and processing resources interconnected by a variety of links. “ RFC 7102 (Jan. 2014)

# Aplicaciones

- industrial monitoring
- building automation (heating, ventilation, air conditioning, lighting, access control, fire)
- connected home
- health care
- environmental monitoring
- urban sensor networks
- energy management
- assets tracking

RFC 7102 (Jan. 2014)



# RSI: origen

## “smart dust” (~2000)

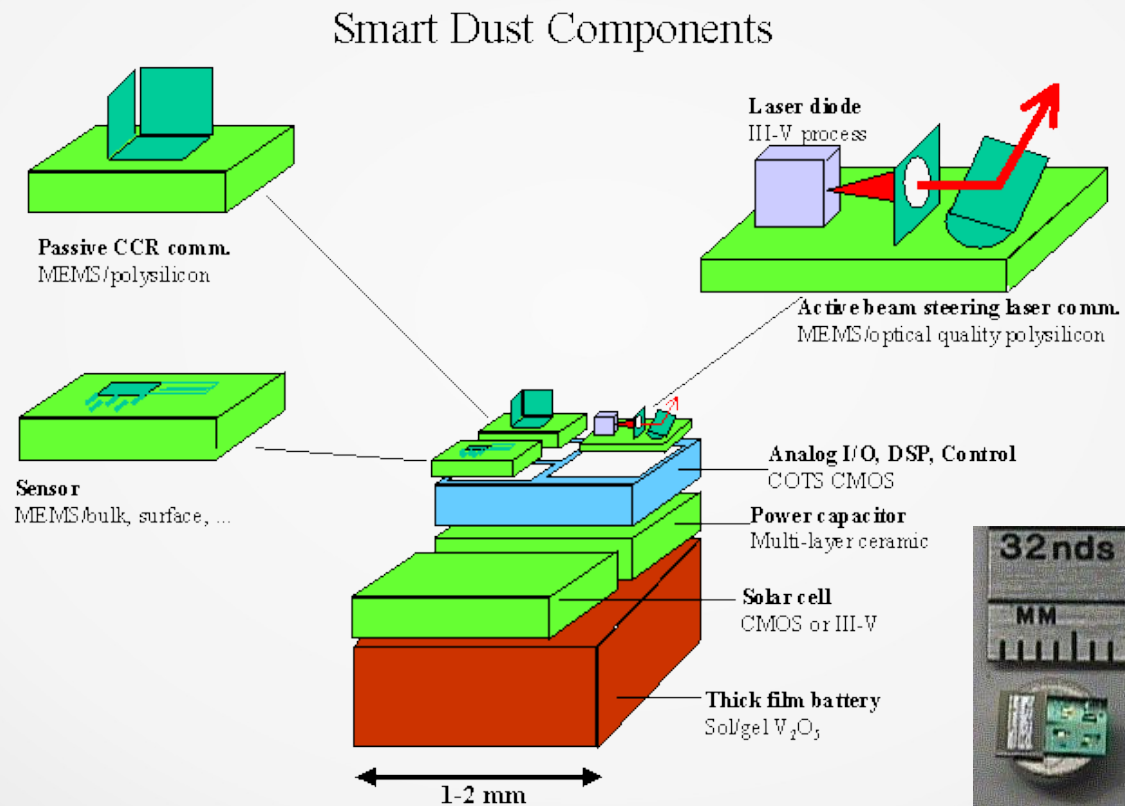

Fuente: <http://robotics.eecs.berkeley.edu/~pister/SmartDust/>

# RSI: evolución Ley de Moore

## Moore's Law – The number of transistors on integrated circuit chips (1971-2018)

Moore's law describes the empirical regularity that the number of transistors on integrated circuits doubles approximately every two years. This advancement is important as other aspects of technological progress – such as processing speed or the price of electronic products – are linked to Moore's law.

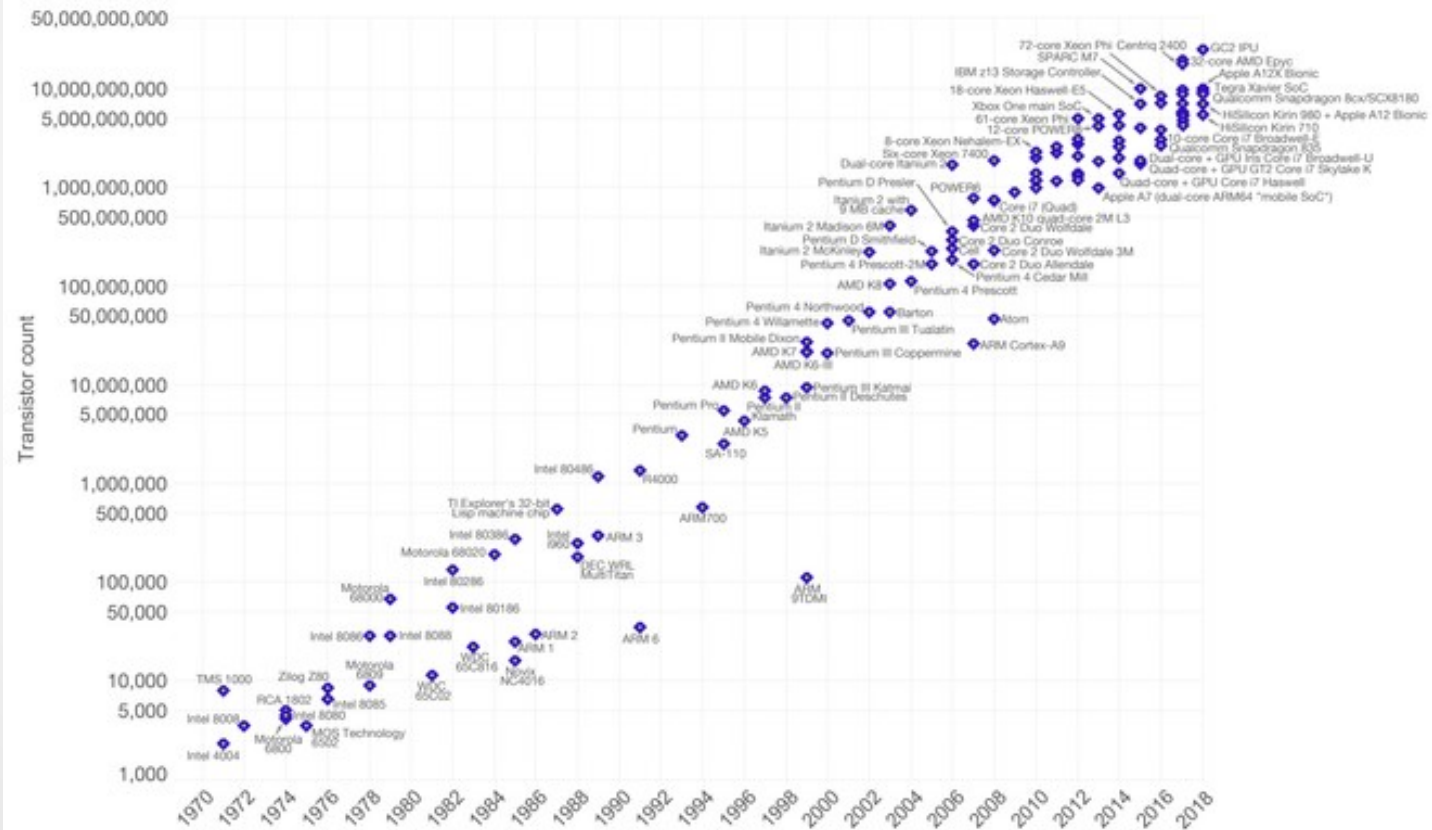

Data source: Wikipedia ([https://en.wikipedia.org/wiki/Transistor\\_count](https://en.wikipedia.org/wiki/Transistor_count))  
The data visualization is available at OurWorldinData.org. There you find more visualizations and research on this topic.

Licensed under CC-BY-SA by the author Max Roser.

# RSI: ¿dónde estamos hoy?

- **TelosB /sky (2005)**
  - MSP430F1611 (8 MHz)
    - 10 KB RAM
    - 48 KB Flash
    - 4mA active / 10 uA sleep
  - CC2420
- **CC2538 SoC (2013)**
  - Cortex M (32 MHz)
    - 32 KB RAM
    - 256 KB Flash
    - ~10 mA active / ~1uA sleep
  - “CC2520” integrado
- Ley de Moore: ¿en qué?

# RSI: elementos / partes

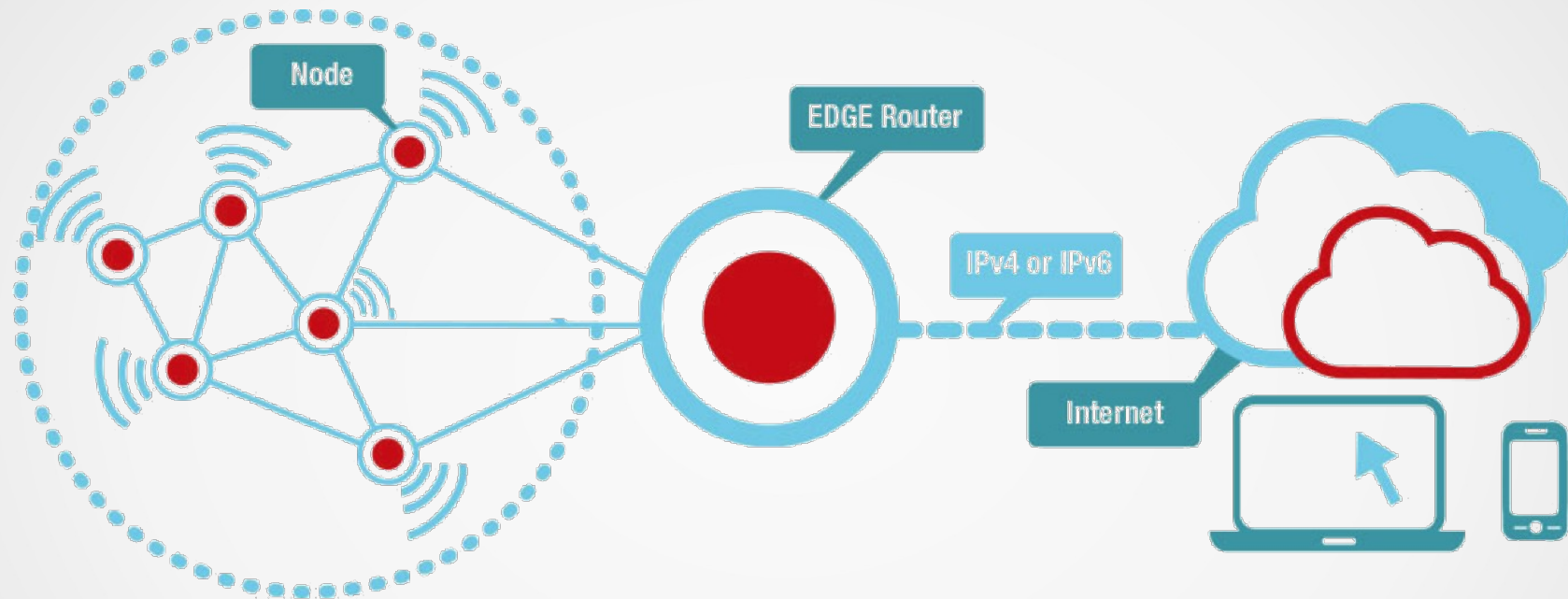

© IIE - Facultad de Ingeniería - UDELAR

# RSI: elementos / partes



base



nodo sensor

red de sensores inalámbricos

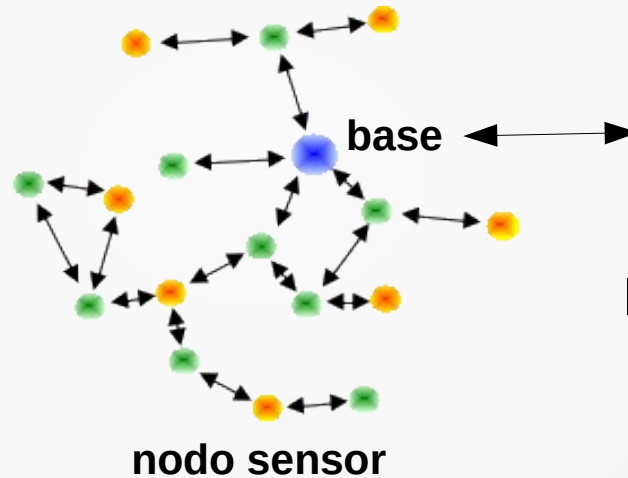

servidor (app/web)

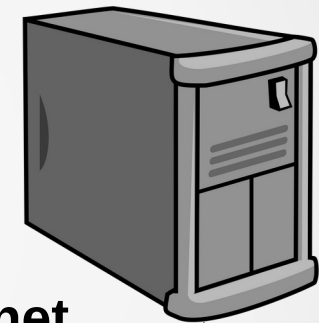

Internet

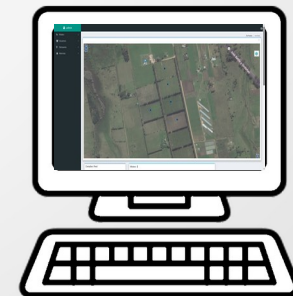

# Nodos

- Características
  - bajo *todo*



costo



tamaño

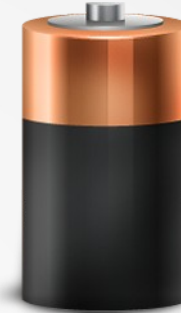

consumo

- Componentes

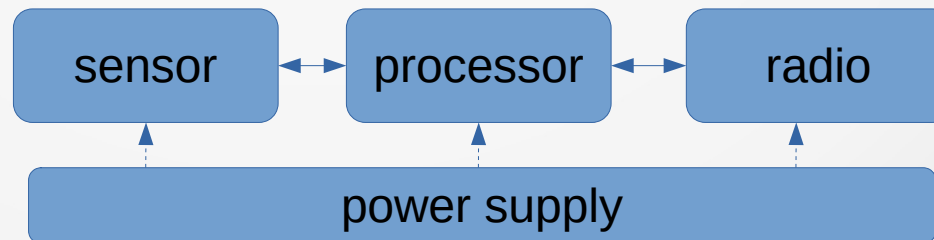

# Nodos: sensores/actuadores

- transductor: magnitud física
- interfaz eléctrica
  - analógica: 0-5V, 4-20mA, etc.
  - digital: SPI, I2C, etc.
- calibración
  - parámetros

# Nodos: microcontrolador

- Procesador: programable, periféricos y memoria integrada
- Funciones
  - input: señales de sensores / output: actuadores
  - procesamiento local de datos
  - ejecución de pila de comunicación

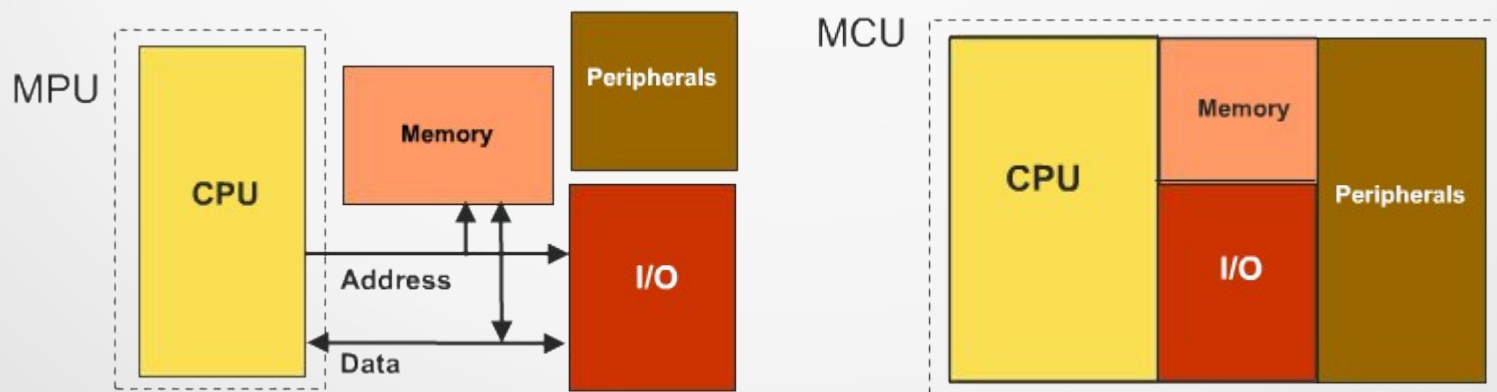



# Nodos: transceptor (radio)

- Transmisor/ receptor: transceptor (capa física)
- Funciones cada vez más inteligentes
  - “modem” vs packet radio
  - pines para interrupción
- Interfaz: comunicación con uC
  - digital serie
  - mapeado en memoria (si está integrado)
- Tecnologías
  - **IEEE 802.15.4**, LoRa, Bluetooth, SigFox, NB-IoT, WiFi, etc.

# Nodos: alimentación

- baterías
- recolección de energía
  - solar, térmica, vibraciones, radiofrecuencia, química
- híbridos
- Convertidores DC-DC
  - step-down
  - step-up

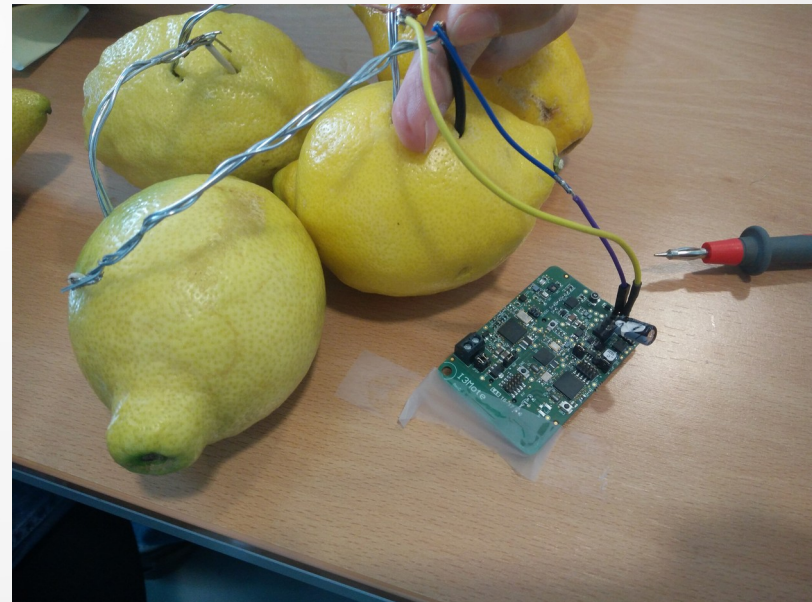

# Tecnologías de comunicaciones



# Clasificaciones de redes de com.

- LAN (Local)
- WLAN (Wireless Local)
- CAN (Campus)
- MAN (Metropolitana)
- WAN (Wide)
- **PAN** (Personal Area Network)
- **WPAN** (Wireless PAN) ← **RSI**
- **LPWAN** (Low Power WAN) ← **RSI**

# Radio: bandas no licenciadas

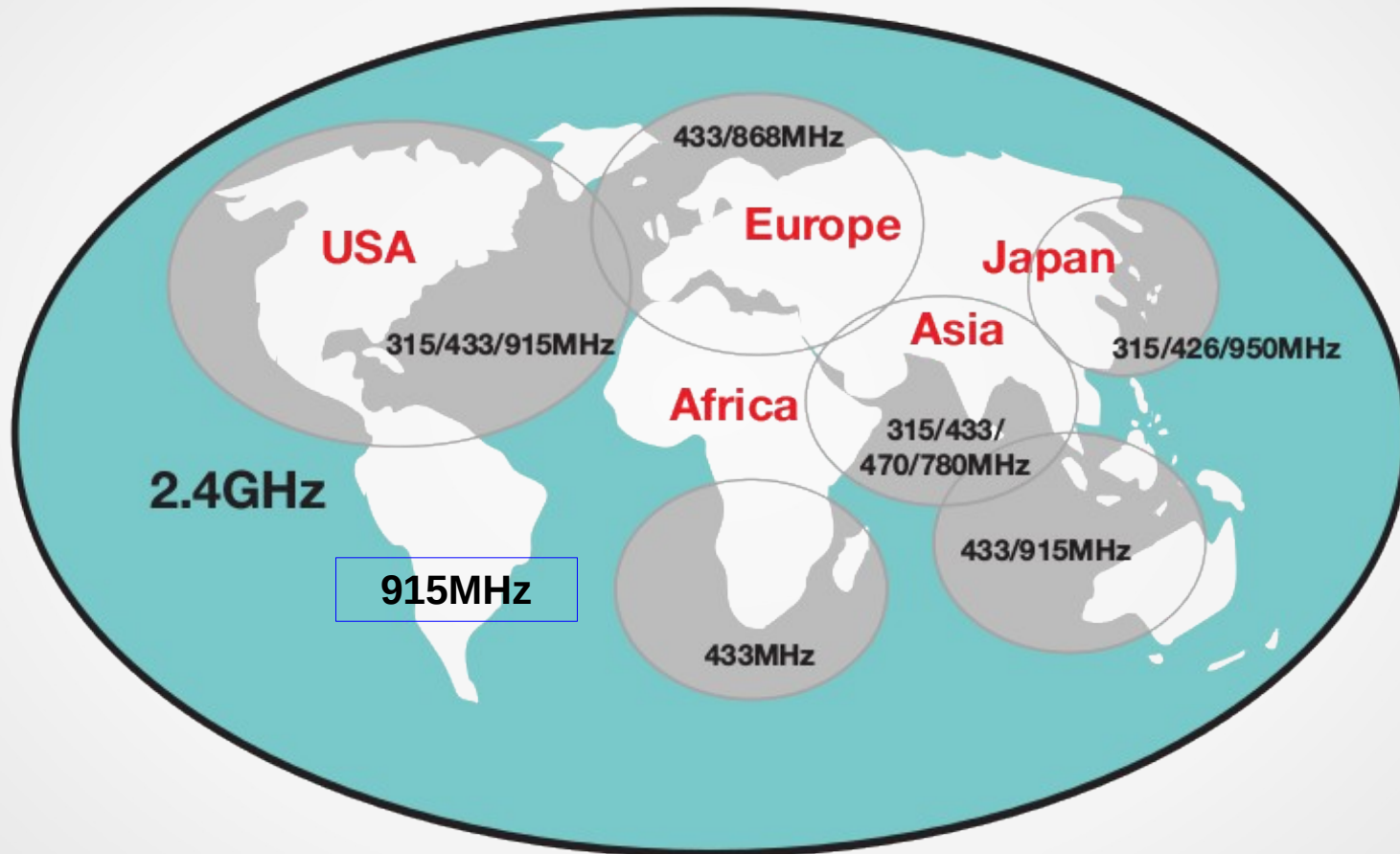

# Tecnologías de comunicaciones

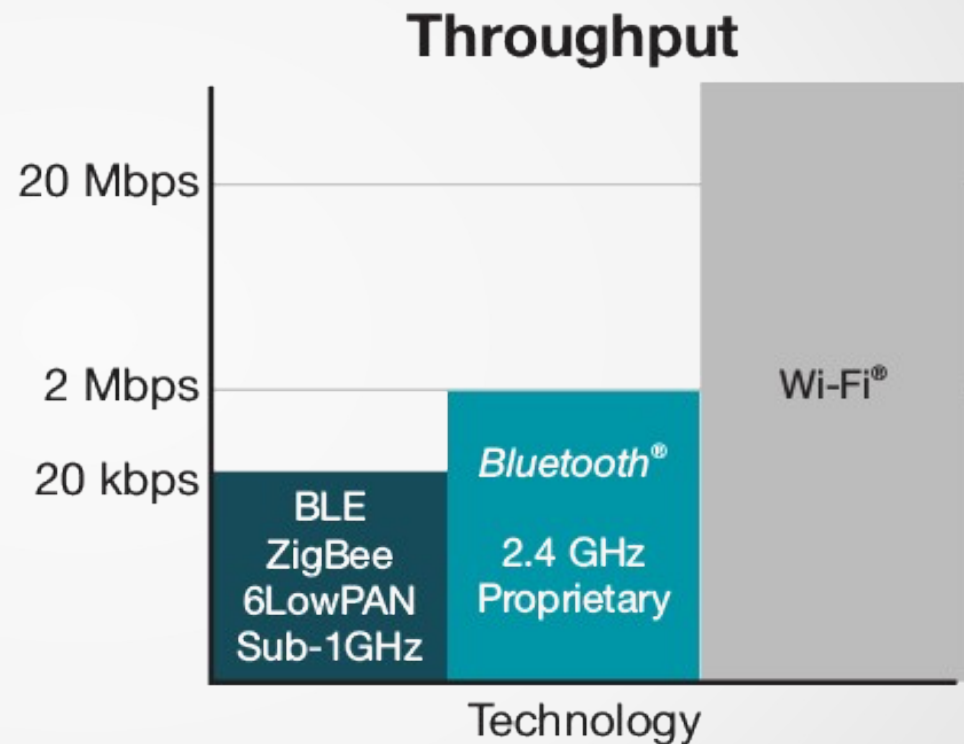
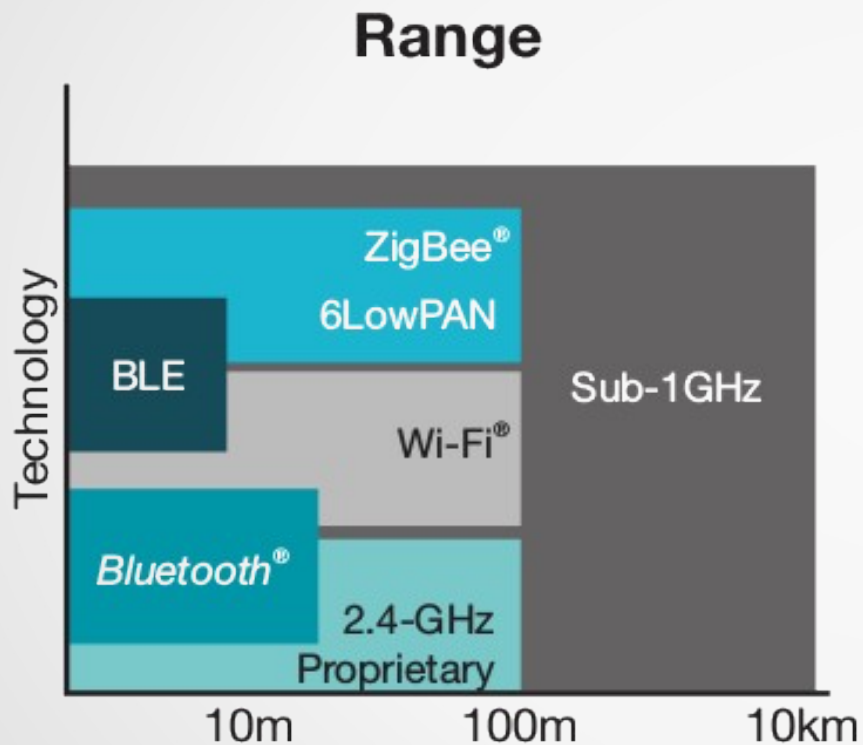

# Tecnologías de comunicaciones

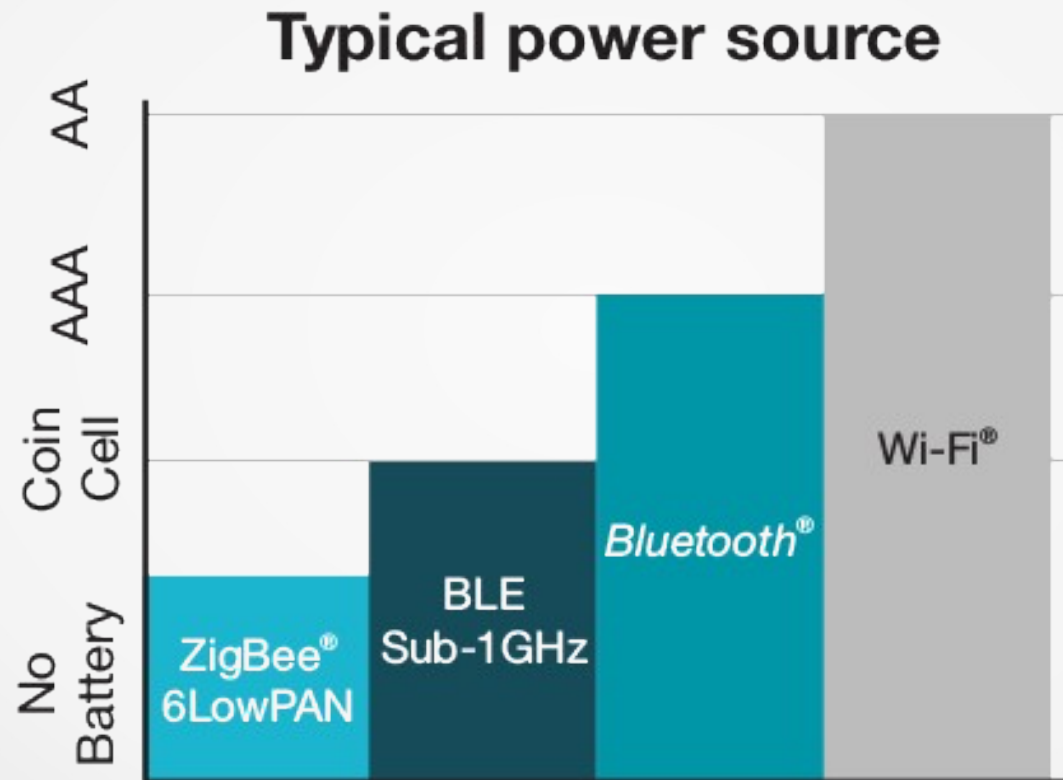

# Arquitectura de comunicación

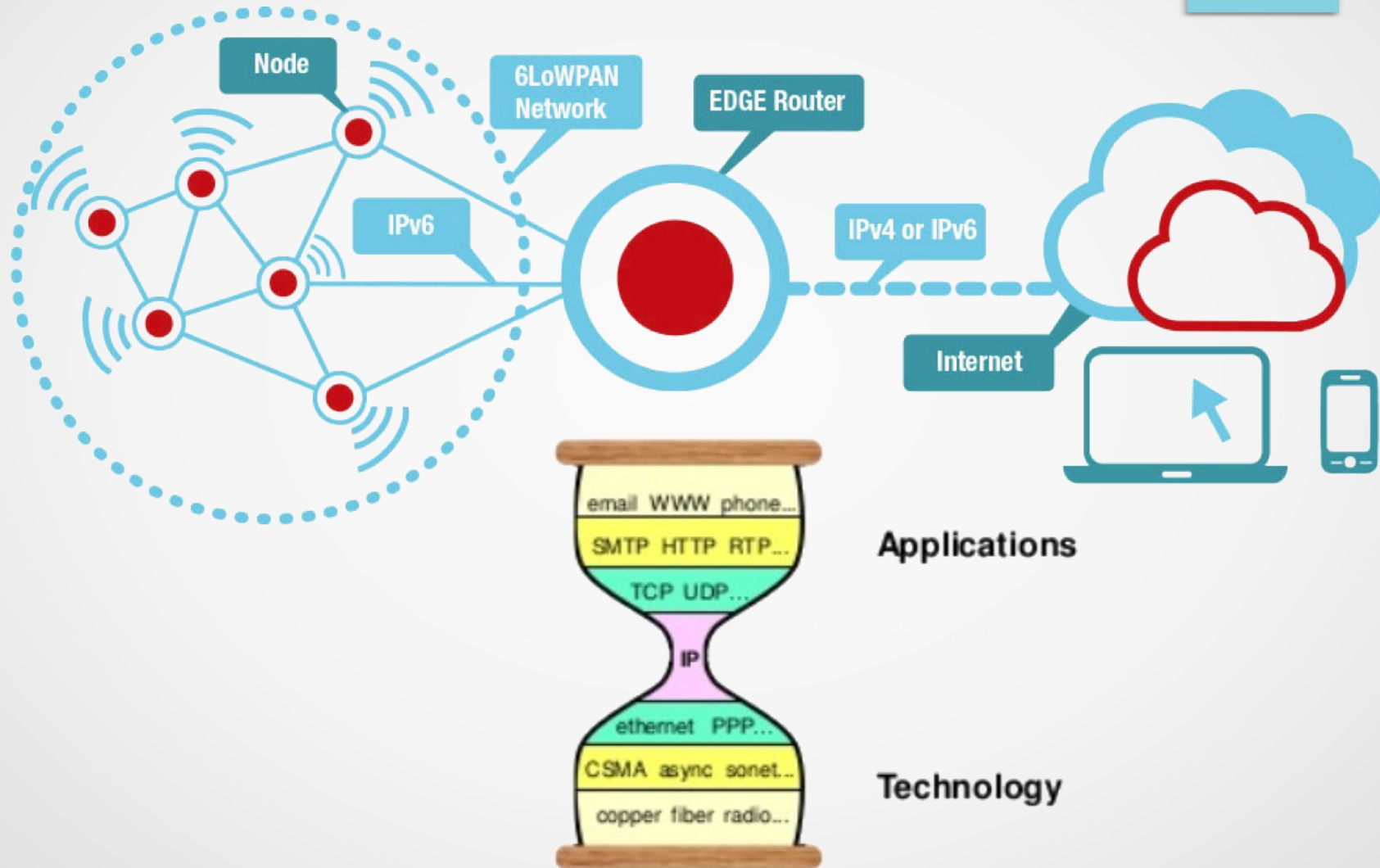



# Pila abordada en el curso

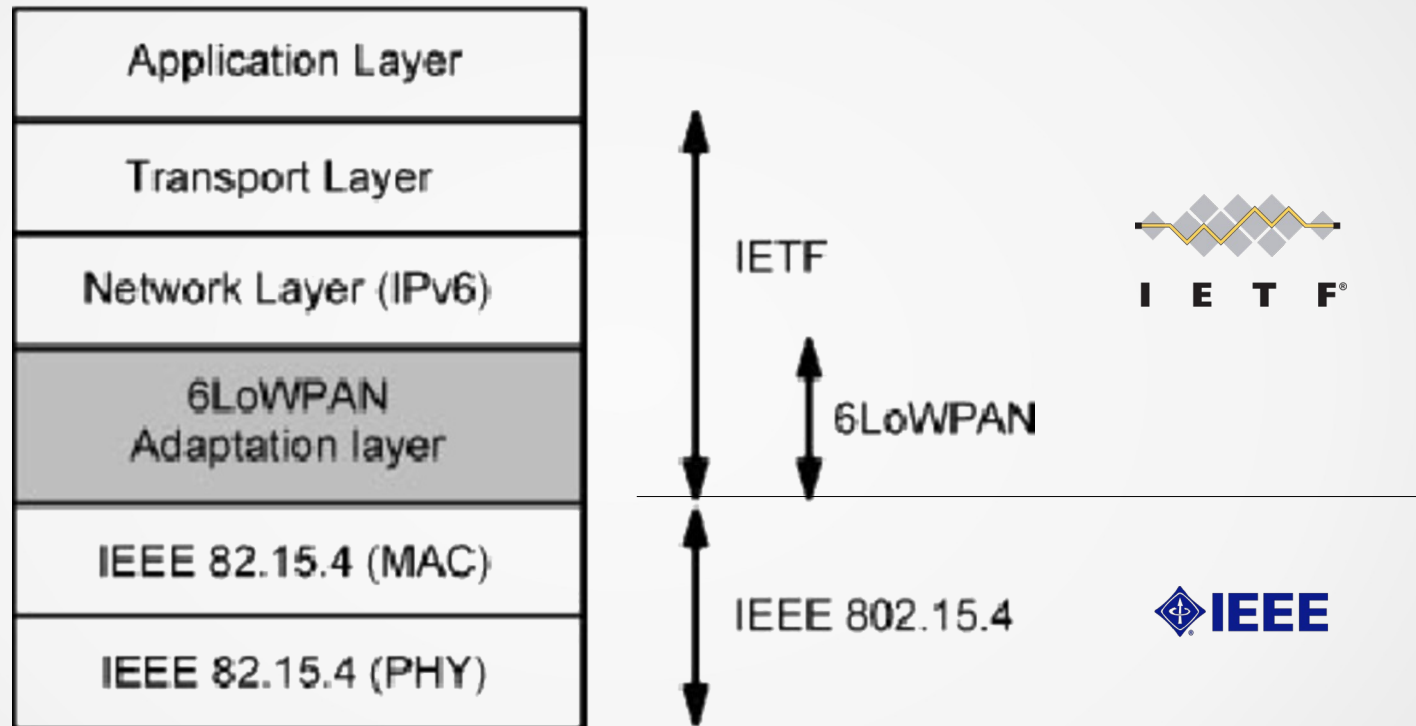

# Pilas sobre IEEE 802.15.4

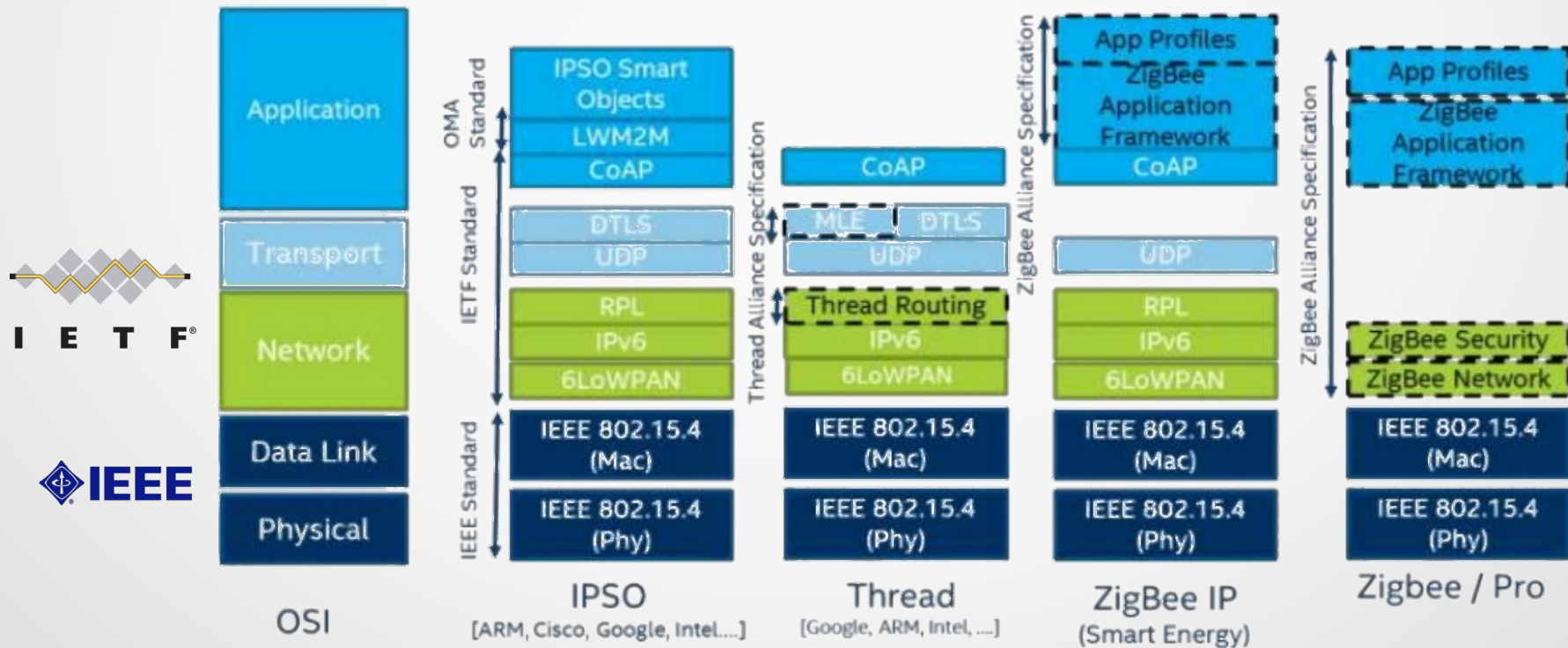
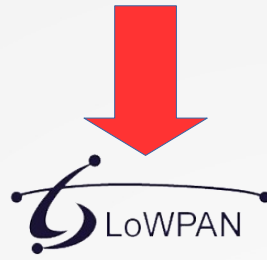

# Pila de comunicación del curso

Layer	Protocol	Standard
Application	CoAP	IETF RFC 7252
Transport	UDP	IETF RFC 768
Network	IPv6 / RPL	IETF RFC 6550
Adaptation	6lowpan	IETF RFC 6282
Data link	IEEE 802.15.4 MAC (CSMA)	IEEE 802.15.4
Radio Duty Cycling	ContikiMAC	-
Physical	IEEE 802.15.4 PHY	IEEE 802.15.4

# Planificación clases

- 1) **Introducción RSI**
- 2) Plataformas de hardware
- 3) Arquitectura 6LoWPAN (IPv6)
- 4) Plataforma de software: Contiki-NG (parte 1)
- 5) Plataforma de software: Contiki-NG (parte 2)
- 6) Capa de aplicación: CoAP / MQTT
- 7) Capa de red: RPL
- 8) MAC
- 9) IEEE 802.15.4 / 6lowpan
- 10) Capa Física & antenas
- 11) IoT y las RSI



¿más preguntas?