

NAVIGATION AND VESSEL INSPECTION CIRCULAR NO. 15-91, CH-1

Electronic Version for Distribution on the World Wide Web

Subj: CRITICAL AREA INSPECTION PLANS (CAIPS)

1. PURPOSE. This Circular establishes the procedures by which owners and operators of vessels required to maintain CAIPs may apply to modify the scope and/or examination intervals established in their initial CAIP.
2. DIRECTIVES AFFECTED. NVIC 15-91, CAIPs, is amended to incorporate the policies and guidance provided, herein, concerning modifications to the scope and frequency of CAIP exams
3. BACKGROUND.
 - a. By the late 1980s, following a number of well publicized marine casualties, the Coast Guard began to focus attention on structural failures of ocean going vessels. The intent was to identify trends in the pattern of structural failures, and to develop recommendations by which to reduce the number and severity of such occurrences.
 - b. On 27 April 1988, the Marine Inspection Program Casualty Review Council issued a report which identified TransAlaska Pipeline Service (TAPS) tankers as suffering a disproportionately higher number of structural failures compared to similar vessels in other areas. In early 1990, the Coast Guard contacted TAPS vessel operators to notify them of changes in inspection policies for these tankships, and to solicit information which the operators themselves had obtained concerning structural failures and their maintenance practices.
 - c. The Coast Guard's "TAPS TANKER STRUCTURAL FAILURE STUDY" cited poorly designed structural details, poor weld workmanship, and fatigue, especially in association with the use of high strength steel, and the harsh environment of the Gulf of Alaska, as contributing causes of structural failures in TAPS vessels.
 - d. The implementation of CAIPs was one of the significant outcomes from this study. Vessels which have experienced, or by virtue of class design and/or service and trade route could expect to experience structural failures, are required to develop CAIPs. As discussed in NVIC 15-91, CAIPs are a management tool developed by the vessel's owner or operator to document and track structural failures, and to monitor the performance of various repair methodologies.

4. DISCUSSION.

- a. The purpose of CAIPs is to provide owners, operators, surveyors, and marine inspectors with detailed information on the vessel's fracture history, corrosion control systems, and repair experience so that structural examinations can be focused upon existing or potential problem areas. The CAIP is intended to record the various repair methodologies employed, in order to ascertain which repairs or modifications have been effective over time.
- b. The aim of the CAIP program is to promote a proactive approach to structural repair which emphasizes identification and remediation of the underlying causes of the structural failure, rather than merely placating the symptoms. The scope and frequency of CAIP examinations is predicated upon the gravity of the structural failures being experienced, and the vigor and success with which the underlying causes of the failures are being addressed.
- c. A CAIP is intended to be a dynamic program, to be modified and revised as circumstances dictate. NVIC 15-91 indicated that affected vessel owners or operators could apply to have certain areas removed from active monitoring, however, it did not provide specific procedural guidance for this process.
- d. The Coast Guard has been pleased with the level of cooperation, professionalism, and quality of information received from vessel owners, operators, and hull surveyors involved in the CAIPs program. As the industry and the Coast Guard have acquired operational experience with CAIPs, it is appropriate now to establish the procedures by which affected owners and operators can apply for modifications to their original CAIP requirements.

5. PROCEDURES.

- a. Owners or operators of U.S. vessels, required by the Commandant to develop and maintain CAIPs, who wish to modify the examination scope and/or interval originally imposed, shall apply to Commandant (G-MVI-1) via the Officer-in-Charge, Marine Inspection (OCMI) who has currently certificated the vessel. Owners or operators of foreign flag vessels who desire similar modifications shall apply to Commandant (G-MVI-1) via the OCMI in whose inspection zone the last CAIP exam was conducted. Owners or operators of vessels required by an OCMI to develop and maintain CAIPs who desire changes from the examination scope and/or interval originally imposed shall apply directly to that OCMI.
- b. Vessel owners or operators may apply for CAIP modifications at any time. Applications must include the following information:
 - (1) Proposed modifications to scope and/or examination interval. The applicant must propose the modification desired. Modifications may include eliminating certain areas from periodic CAIP examination, downgrading certain areas from active repair areas to critical inspection areas, extending the interval between CAIP examinations, or a combination of these factors.
 - (2) Justification for the CAIP modification. The burden is on the applicant to Justify why the desired CAIP modifications are appropriate. Modifications may be Justified by a number of factors, which may be considered individually or in combination, depending upon the individual vessel's circumstances.

- (a) A record of internal structural examinations which indicate that the area under consideration has not experienced a history of structural failure
- (b) Successful remedial efforts which addressed the cause of a structural failure, such as a detail modification, may justify a change in the CAIP. Generally, for purposes of amending a CAIP, a detail modification may be deemed successful if it has not fractured, nor redistributed a hard spot or stress riser to another location, within one year, or within the originally specified examination time interval, whichever is greater. Similarly, inserts and in situ repairs (gouge and reweld) may be deemed successful if no refracturing has occurred within one year or within the originally specified examination time interval, whichever is greater. Modifications which have significantly reduced the incidence and/or severity of fractures to the point where they no longer pose a threat to the structural or oil tight integrity of the vessel may also be considered "successful" for the purpose of supporting a CAIP modification, provided that similar unmodified details in the same tank have not experienced increased fracturing.
- (c) Active repair areas experiencing recurrent Class 1 fractures will not be eligible for scope or interval relaxation. However, the presence or recurrence of certain Class 2 or "nuisance" type Class 3 fractures may not necessarily preclude increasing the CAIP examination interval in that active repair area. An appropriate fracture mechanics analysis should be submitted which demonstrates that Class 2 or Class 3 fractures will not propagate to critical length in the proposed time interval, using a safety factor of at least 2.5. Similarly, it may be possible to demonstrate that a change in the vessel's operational characteristics, such as route and speed changes, voyage planning programs to avoid encounters with adverse sea conditions, or alterations of loading or ballasting patterns, could reduce the stresses to which the vessel is subject, thereby increasing the time for a crack to propagate to critical length. An appropriate fracture mechanics analysis should take into account the identification of specific details, flaw size, fracture toughness of the plates studied, estimates of the equivalent root mean squared stress range to which a vessel is subject, and estimates of the resultant crack propagation life, and a proposal for a reasonable examination interval. An example of a fracture mechanics methodology for oil tankers is provided as enclosure (1). Studies conducted for the purposes of increasing the CAIP inspection interval based upon fracture mechanics methodologies, and operational changes should be provided to the vessel's Classification Society for review and comment prior to submission to the Coast Guard.
- (d) Examinations conducted by an International Association of Classification Societies (IACS) member classification society pursuant to the enhanced survey requirements for oil tankers required by the 1992 Amendments to Annex I of Regulations for the Prevention of Pollution by Oil 73/78, Regulation 13G, may be substituted for CAIP exams if shown to be substantially equivalent in scope, intent, and effect as the examinations conducted pursuant to CAIP requirements.

- (e) Examinations conducted by an IACS member classification society pursuant to the enhanced survey requirements for bulk carriers established by IACS in response to the International Maritime Organization, Resolution 713(17) of 6 November 1991, may be substituted for CAIP exams if shown to be substantially equivalent in scope, intent, and effect as the examinations conducted pursuant to CAIP requirements.
 - (f) The additional factors presented in support of the proposed modification will dictate the degree of enhanced survey substitution permitted. Substitution could be limited to a one time grant to extend the CAIP exam to coincide with an enhanced survey. Alternately, if conditions warrant, the scope and frequency of the enhanced survey might be accepted in place of the CAIP requirements entirely.
- (3) Baseline examination data. The baseline examination data is the vessel's structural condition as it existed following its first CAIP exam. Information concerning the type, amount, and location of fractures found, and the repairs effected, should be indicated. In most cases, this information should already be documented as part of the historical information recorded in the vessel's CAIP portfolio. If so, the applicant need only reference the pertinent entry in the CAIP portfolio. It is the applicant's responsibility to ensure that the reviewing authorities are provided with copies of all relevant information.
 - (4) Latest examination data The latest examination data is the vessel's structural condition as found at the most recent CAIP examination, internal structural examination (ISE), or enhanced survey. The latest examination includes all critical inspection areas and active repair areas as defined in NVIC 15-91. The latest examination data must identify the type, amount, and location of repairs, such as detail modifications, inserts, gouge and reweld, etc., which have been effected since the baseline exam, and the success of the repair methodology. The latest examination data must indicate if any new fractures or structural discrepancies have been discovered, and the repair methodology employed, as applicable.
 - (5) Endorsement by classification society. Owners or operators of classed vessels must include a favorable endorsement of their proposed CAIP modification from their classification society.

6. IMPLEMENTATION

- a. Owners and operators who wish to modify their vessel's CAIP requirements shall follow the procedures specified in paragraph 5 of this Circular. The latest examination must be conducted and witnessed by the relevant OCMI (the OCMI's identified in paragraph 5.a of this Circular). Owners and operators contemplating CAIP modifications must contact their relevant OCMI's and provide them with adequate notice of the time and location where the latest examination is to be conducted.

- b. OCMI shall attend CAIP examinations to the extent they deem necessary to verify the applicant's findings, and to permit them to make an informed recommendation concerning the propriety of accepting the applicant's modification proposal.
- c. OCMI shall review all CAIP modification requests to ensure that the applicant has provided the necessary information required by paragraph 5.b of this Circular. OCMI may approve modifications to all CAIPs for which they were the implementing authority. OCMI shall forward modification requests for all other CAIPs, with their recommendations, to Commandant (G-MVI) via their District Commander (m).
- d. Commandant (G-MVI-1) will review applicants' requests and make the decision whether or not to accept the proposed modifications based upon the information provided by the applicant, the endorsement of the cognizant classification society or authority which has issued the vessel's Safety Construction Certificate (if applicable), the recommendation of the relevant OCMI and District Commander (m), and a review of the vessel's CAIP record. Commandant (G-MVI-1) will provide applicants with written decisions which specify the new terms of the CAIP, as applicable.
- e. Vessel owners or operators shall amend and maintain their vessel's CAIPs to reflect any changes accepted by cognizant Coast Guard authorities.
- f. OCMI are urged to give this Circular wide dissemination. OCMI are encouraged to work with affected vessel owners and operators to ensure that the ultimate aim of the CAIP program, effective tracking and management of the vessel's structural condition, continues to be realized.



J. C. CARD
Rear Admiral, U.S. Coast Guard
Chief, Office of Marine Safety,
Security and Environmental Protection

End: (1) Fracture Mechanics Methodology For Fracture Control In Oil Tankers

FRACTURE MECHANICS METHODOLOGY FOR FRACTURE
CONTROL IN OIL TANKERS

by
S. T. Rolfe¹
A. E. Henn²
and
K. T. Hays³

ABSTRACT

Fracture mechanics has become the basic methodology to predict and analyze the fracture behavior of structural steels used in complex welded structures such as bridges, off-shore rigs, pressure vessels and oil tankers. Recent studies of the crack-tip opening displacement (CTOD) fracture mechanics methodology shows that this technology can be used to describe elastic-plastic fracture behavior in the temperature region where oil tankers operate. Thus, this technology offers real potential for use in developing a straight-forward method for applying fracture mechanics concepts to predict critical crack sizes in oil tankers.

Oil tankers, such as those in the Trans-Alaska Pipeline Service (TAPS), are subjected to fairly severe wave loadings on a routine basis. The severe wave loadings result in high cyclic stresses and undetected cracks may grow by fatigue to lengths approaching the critical crack length of the hull steel at extreme service conditions. The ability to predict crack growth rates and the critical crack lengths in hull structures is essential for insuring the integrity of tankers and for formulating hull inspection plans and repair criteria.

This paper describes studies on the prediction of critical crack sizes and fracture control based on the elastic-plastic fracture methodology, crack-tip opening displacement (CTOD). Fatigue crack growth also can be predicted using fracture mechanics and the paper describes the methodology to predict the fatigue behavior of structures that have existing cracks.⁴

¹ Professor, University of Kansas, Chairman, Department of Civil Engineering

² Rear Admiral, U. S. Coast Guard, Chief, Office of Marine Safety, Security and Environmental Protection, U. S. Coast Guard Headquarters, Washington, DC

³ Lieutenant Commander, U. S. Coast Guard, Chief, Safety and Oversight Section, U. S. Coast Guard Headquarters, Washington, DC

⁴ The U. S. Coast Guard created an industry working group to help develop a methodology for fracture control in oil tankers. The group was composed of representatives from Exxon Shipping Company, BP Oil Company, and American Bureau of Shipping. It met periodically to develop the methodology and the information used for the example in this paper. Their help is greatly appreciated.

INTRODUCTION

Oil tankers in the Trans-Alaskan Pipeline Service (TAPS) are subjected to fairly severe wave loads on a routine basis. This loading can lead to fatigue crack initiation and propagation at certain fatigue-sensitive details. During inspection of critical details in some oil tankers, fatigue cracks have been discovered. Since the fatigue initiation life of these details already is exhausted, the prediction of the remaining propagation fatigue life must be made using a fracture mechanics crack-propagation methodology. Determination of the remaining fatigue crack propagation life is essential in establishing inspection intervals to insure the safety and reliability of these oil tankers for continued safe service in the TAPS trade.

This paper describes the methodology used to establish the remaining fatigue crack propagation life and representative inspection intervals for a specific ship detail, namely bottom shell plates near longitudinal drainage and master butt weld cut outs. This methodology can be applied to other types of ship details, provided the steps below are performed for each particular detail. Briefly the methodology consists of the following steps:

- 1) Identification of specific details where cracks occur and selection of a stress intensity factor, K , that describes the stress field at that detail.
- 2) Inspection of these details to establish a representative initial flaw size, a_0 , to be used in a fatigue crack propagation analysis.
- 3) Determination of a representative fracture toughness value of the steel plates used in the details under study. By knowing the maximum stress to which these details will be loaded, the critical crack size can be estimated. The critical crack length is the length that a crack must reach before the crack can propagate in a brittle fashion. This length depends on material toughness and applied stress level so it is not a material property.
- 4) Use of histograms to estimate the equivalent root-mean square stress range, Δ_{RMS} to which the ship is subjected to for a specific loading season. This Δ_{RMS} value can be used in existing crack propagation equations to estimate the number of cycles of loading (N_p) it takes a crack to grow from the initial crack size, a_0 , to the final or critical crack size, a_{CR} .
- 5) On the basis of this estimate of the crack propagation life (N_p), establish reasonable inspection intervals for safe and reliable service.

Determination of fatigue crack propagation lives for a particular critical crack size for specific structural details is a complex process and cannot be generalized for different details or structures. Each type of detail and loading must be analyzed individually. Accordingly, this paper presents a generalized methodology that can be used with specific details and then presents one single example for what is considered to be a representative loading of one detail in one class of tankships in the TAPS trade.

BACKGROUND

The United States Coast Guard has conducted an extensive review of cracking reported between 1984 and 1988 on the 69 vessels over 10,000 gross tons in the TAPS trade during that time frame (1). These studies revealed that while the TAPS fleet comprised only 13% of the U.S. flag fleet, these tankers accounted for 59% of all of the reported fractures. Additionally, 73% of the reported TAPS fractures occurred on only 24 of the 69 ships.

As a result of this study, the Coast Guard implemented a detailed inspection program of problematic, critical fracture areas, and new reporting requirements for vessels experiencing a high frequency of structural cracking. These requirements are published in Navigation and Vessel Inspection Circular (NVIC) 15-91, "Critical Area Inspection Plans (CAIP)". The CAIP NVIC has worked very well since 1991. However, the high cost of inspection, vessel maintenance, out of service time, and documentation dictate that both the Coast Guard and ship owners work together to reduce the incidence of this cracking. Also, a need exists to develop a methodology that can optimize inspection intervals, validate how serious these fractures are, predict fatigue behavior of ships with existing cracks, and establish effective repair procedures. This information could then be used to justify relaxation from NVIC 15-91 vessel specific requirements after a period of good vessel performance.

The Coast Guard review of vessels in the TAPS trade noted that hulls fabricated from HTS steel experienced a disproportionately higher number of structural cracks than did hulls fabricated from mild steel plates. Although the design rules allow the allowable stress to rise as the HTS yield strength increases, the fatigue strength of HTS steel remains about equal to that of mild steel and offers no advantage in this area. As the operating stress range increases, the number of cycles to fatigue failure generally decreases (reduced fatigue life), and the subsequent fatigue damage may end up being greater than would be the case in a similar mild steel detail. This fact, combined with thinner scantlings from the use of HTS steel, as well as possible further reduction in scantlings by corrosion, may lead to early fatigue cracking in tankers fabricated from HTS steel.

These factors all indicate the need for the improvement of methods for addressing fatigue in design and maintenance of ships. There has recently been a great deal of progress in this area for ship design. The American Bureau of Shipping (ABS) Guide for the Fatigue Strength Assessment of Tankers (2) can be used to assess the expected fatigue initiation life of a detail but not the critical issue of fatigue crack growth. This issue is more important after cracks have been detected on an existing ship. Many of the new methods used by the industry today use the Miner's Rule approach (cumulative damage theory) to estimate fatigue initiation life. Miner's Rule ignores much of the fatigue crack propagation life in actual structures by assuming failure soon after crack initiation in laboratory specimens. While this approach is suitable for predicting the general fatigue behavior of a ship, it is not suitable for examining the behavior of existing fatigue cracks in existing oil tankers.

A review of all presently available fracture mechanics methods shows limitations on all of them (3). Although the theory of fracture mechanics for ductile materials has not been fully developed yet, the current technology has advanced to the point that fracture mechanics can be applied to the repair of existing ships. The elastic-plastic crack-tip opening displacement (CTOD) fracture mechanics methodology is used to determine critical crack sizes. The well-established da/dn fatigue crack growth behavior is used to estimate the fatigue crack propagation life.

FRACTURE MECHANICS METHODOLOGY

A rational fracture mechanics methodology for fracture control in existing oil tankers consists of five general parts:

- 1) Identify the critical details and develop a stress intensity factor relationship, K_I , for those details.

- 2) Make a realistic estimate of what size cracks can be found during a critical area inspection with a high probability of detection. This is the initial crack size, a_0 , used in the fatigue crack propagation studies.
- 3) Conduct fracture tests to estimate the fracture toughness K_{Ic} , at the service temperature. Use this toughness level, the K_I relation from Item 1, and the maximum stress to which the detail in question is subjected to calculate the critical crack size, a_{CR} .
- 4) Calculate a histogram displaying stresses that the critical area will experience over the time period of interest. The histogram should display the root mean square (RMS) fatigue stress ranges calculated for a predictable period, e.g., one year. Using the K_{Ic} fatigue loading, calculate the expected fatigue life for cracks that are undetected in the critical area after inspection, i.e., values of a_0 from Item 2.
- 5) Establish reasonable inspection intervals using the crack propagation life calculated in Item 4.

Using this general methodology, a specific detail in a representative tanker in the TAPS trade is analyzed as an example of the use of this methodology.

APPLICATION OF METHODOLOGY TO A DETAIL IN AN OIL TANKER

A) Identification of Critical Details

Fatigue cracks have been observed in some classes of tankers engaged in the TAPS trade (4). These tankers are subjected to fairly severe service loads on a routine basis and this loading, plus the use of highstrength steel in fatigue sensitive details, has led to cracking. On one class of tankers in particular, the details where cracking is most severe are:

- 1) side shell longitudinal bracket connections to transverse bulkheads and to web frames,
- 2) webs of bottom shell longitudinal stiffeners, and
- 3) bottom shell plates near longitudinal drainage and master butt weld cut outs.

Analysis of these details on this class of tankers indicates that while all cracking in ships potentially can be serious, the first two types of cracks appear to be less severe and are being addressed by inspection and repair, improvement of details, grinding of poor weld contours, hammer peening, and the use of drilled holes as crack arrestors.

Cracking in the third category of details, however, is more difficult to detect and has the potential of leading not only to a through thickness penetration of the bottom shell plating, but possibly to rapid fracture in the tankers. Accordingly, this study has focused on the significance of bottom shell cracks with respect to the overall structural integrity of these tankers. Finally, recommendations are made regarding hull girder inspection criteria.

B) Fracture Toughness

Crack-tip Opening Displacement (CTOD) fracture tests were conducted on 3/4-inch thick AH-36 steel plates taken from tankers in this one class of TAPS vessels, using ASTM Standard E1290. Each specimen used the full plate thickness, after surface grinding to a uniform thickness. The specimen sizes

were approximately 3/4-inch x 1.5 inch. Analysis of these results indicated that, as expected, there was considerable variation in the CTOD results for various plates and weldments. Results presented in Table I show CTOD test results for two typical bottom shell plates plus one weld and one heat-affected zone (HAZ). At 32₀F, a representative minimum bottom shell plate temperature, the CTOD values for base metal can average as low as 2.4 mils. This value is consistent with unpublished test results obtained from other tankers. Test results for weld metal and HAZ specimens were higher (8.6 and 15.3 mils, respectively).

The base metal toughness is of greatest interest since most fatigue crack growth probably occurs in base metal. Accordingly, a conservative value of 2.4 mils was selected as a representative minimum value to analyze the behavior of the bottom shell plates in this one class of vessels subjected to TAPS service.

A value of 2.4 mils for base metal can be related to an equivalent K_C by:

$$K_C = \sqrt{m_c \cdot F_L E}$$

where K_C = critical stress intensity factor, ksi \sqrt{in}

$m = 1.7$ based on research studies of structural grade steels (12)

$c =$ CTOD value, 2.4 mils

$$F_L = \text{flow stress (average of yield and tensile strength)} = \frac{55 + 85}{2} = 70 \text{ ksi}$$

$E =$ modulus of elasticity

$$K_C = \sqrt{(1.7)(0.0024)(70,000)(30,000,000)}$$

$$K_C = 92.5 \text{ ksi} \sqrt{in}$$

For a CTOD value of 29 mils (see Table I), the estimated K_C approximately 322 ksi \sqrt{in} . Thus there is considerable scatter in the toughness of these steels based on a limited sample analysis.

Charpy V-notch (CVN) test results of these same two plates and results of other plates presented in Table I show that the toughness of about 2.4 mils is at the lower range of values for this particular steel.

Therefore, as a representative value, the toughness level of about 100 ksi \sqrt{in} is selected as a reasonable lower bound value to use for subsequent critical crack size calculations. It should be noted that at the time of construction of this particular class of vessels, there were no CVN specifications for AH-36 steel in the ABS Rules for Steel Vessels (5). The specifications in the ABS Rules for Steel Vessels now is 25 ft-lbs. Of the five typical 3/4-inch thick bottom plating samples tested, three had CVN values below this 25 ft-lb minimum. As noted later, the fatigue life of these tankers is not that dependent on notch toughness as long as the critical crack size is reasonably large, as it appears to be for these tankers.

C) Stress Intensity Factors and Critical Crack Size for Critical Details

To predict critical crack lengths, estimates of the material toughness, K_C and the maximum likely stress level, σ_{max} , that occurs during maximum sea states are required. The toughness and maximum stress level are used in an expression for K_I , the stress intensity factor that best represents the actual structural geometry in the bottom shell plates to calculate critical crack lengths. Different geometries require different K_I relations, as described in ref. (6).

For an unstiffened bottom shell plate, the relatively simple expression for a through-thickness crack in a semi-infinite wide plate would be appropriate (6,11). This expression is:

$$K_I = \sigma_{max} \sqrt{a}$$

Values of critical toughness ($K_I = K_C$) and maximum stress ($\sigma = \sigma_{max}$) are used to calculate the critical crack size, a_{CR} . Actually the critical crack length is twice this value or $2a_{CR}$ because of the nature of the stress intensity equation (6,11). Because the bottom shell plate actually is stiffened, the above expression should be modified to account for the effect of the presence of a single stiffener perpendicular to the crack (6). A review of the effect of stiffeners on K_I values leads to the conclusion that the K_I value in a stiffened plate is about 0.7 of the K_I value for an unstiffened plate. This value of 0.7 will be used to correct the value of stress range in the analysis of fatigue crack growth and is referred to as the single stiffener reduction factor (RF_{SS}) in the section on "Fatigue Crack Propagation in Bottom Shell plates". It would be desirable to verify this assumption experimentally.

For very long cracks that have crossed several stiffeners, the effect of these stiffeners on the stress intensity factor is greater. This observation may help to explain why cracks of several feet in length crossing one or more stiffeners may not lead to a rapid fracture. Thus, in addition to preventing plate buckling during compressive loading, longitudinal stiffeners may act as crack growth retarders (possibly even arrestors) for severe stresses during tensile loading. The fact that stiffeners have this effect emphasizes the need to repair all cracks in the webs (and flanges) of longitudinal stiffeners near drainage and weld cut outs at each inspection.

The K_I expression for an unstiffened plate is modified by reducing the maximum stress by a reduction factor of about 0.6 (RF_{MS}) to account for the beneficial effect of several stiffeners. As noted in Reference 6, the actual effect of several stiffeners may be to reduce the K_I by a factor greater than 0.6. This observation also should be verified experimentally. However, using a RF_{MS} factor of 0.6, the relation for critical crack size, $2a_{CR}$ therefore becomes:

$$K_C = (RF_{MS}) \sigma_{max} \sqrt{a_{CR}}$$

$$2a_{CR} = \frac{2}{(0.6)^2} \left(\frac{K_C}{\sigma_{max}} \right)^2$$

Previously, it was shown that a reasonable lower bound toughness, K_C , is about 100 ksi \sqrt{in} . Members of the industry working group estimated the maximum stress to be about 30 ksi, although discussions with ABS personnel have indicated that the actual maximum stress might be slightly higher. This observation is based on the fact that the predicted wave environment for the actual TAPS route used to calculate these stresses was found to be less harsh than the traditional North Atlantic wave environment

ABS would normally use to calculate stresses. Therefore, assuming that the maximum stress, σ_{max} , can be as high as about $\frac{2}{3} \sigma_{ys}$, or about 34 ksi, $2a_{CR}$ is estimated to be:

$$2a_{CR} \cong \frac{2}{\left(\frac{100}{(.6)(34)} \right)^2}$$

$$2a_{CR} = 15 \text{ inches}$$

It is important to note that the stress RF for a single stiffener, RF_{SS} , is to be applied only when a crack is small as it is during the early stages of fatigue crack propagation. The stress reduction factor for multiple stiffeners, RF_{MS} , is to be used to estimate critical crack length, when the crack may be fairly large.

It should be noted that 15 inches is a fairly conservative value for the critical crack length because the lowest measured toughness level and a fairly high probable stress value were used to estimate the critical crack length. Also the effect of several stiffeners may result in a reduction factor less than 0.6 and thus increase the critical crack size even further. However, even if the critical crack size were larger, the calculated fatigue crack growth rate is fairly high (because of the large crack length) resulting in only a slight increase in fatigue life. In other words, even if the critical crack length were larger than 15 inches, the fatigue life would not be significantly longer. This is why it was stated earlier that the fatigue life is not that dependent on notch toughness as long as there is some reasonable level of notch toughness. Even if the material had a higher K_{IC} , the crack growth rate is fairly large at this point, and a tougher material would not increase the fatigue crack propagation life significantly. Thus a critical crack size of about 15 inches is assumed for the bottom shell plates in this example, realizing that in most cases it probably is higher.

D) Inspection capability for Initial Crack Size, a_0

Determining a realistic value of the size crack that can be detected reliably is likely the most difficult aspect of a fracture control methodology. The probability of detection (POD) of a fracture varies from inspection to inspection and is dependent on a variety of factors. These include degree of surface cleanliness, lighting, inspection techniques used, inspector experience level and familiarity with the vessel class, vessel loading condition, condition of the coating system, and the location of the critical structural detail in the ship. No POD curves were currently available for ship structures. However, work has been done on how to develop a POD curve for vessel inspection, Holzman (7). This procedure may be used to evaluate the POD of various lengths of fractures for the particular structure being evaluated.

Lacking such POD information, a conservative estimate for each critical area, taking into account the factors listed above, should be made about what size cracks can reasonably be found. This value should be used in fatigue crack propagation studies as the initial flaw size, a_0 , assumed to exist in the structure after an inspection has been completed. In an article about their new fatigue guide for tankers, the American Bureau of Shipping recently noted that ship operators constantly detect and repair cracks of three to four inches (8). It is interesting to note that these values are similar to what was estimated in the example to be presented below. For the particular class of TAPS tankers evaluated for this study, U. S. Coast Guard inspectors estimated that surface cracks could be detected in the areas identified as critical with a high degree of confidence. These detectable cracks were estimated by the inspectors to be 3 inches in length using visual means, and 2 inches in length using either ultrasonic or magnetic particle inspection techniques.

E) Determination of Histogram for Fatigue Loading

In developing the stress histogram, the most accurate estimate of actual stresses experienced by the critical area member (both fatigue stress ranges and extreme stress values) should be made. The calculations would include using seasonal based wave scatter data to account for the effect of loading history. A hydrodynamic model can be used to develop global wave-induced hull girder vertical and horizontal bending moments, external and internal hydrodynamic pressures, and internal and inertial induced pressures, and then finite element analysis may be used to develop local critical area stresses. Consideration should be made for the effects of vessel speed, loading conditions, wave directionality, and wave spreading, or termed differently, “short” and “longcrestedness”, as it varies during each voyage. Statistical analyses of the wave scatter data and the subsequent lifetime fatigue and the extreme stresses may be based on the formulation by Ochi (9,10). The fatigue stress range histogram is then used to calculate the root mean square stress range value for each season, Δ_{RMS}

Using these procedures, a dynamic stress range histogram was developed for the subject tankers by American Bureau of Shipping representatives. National Oceanic and Atmospheric Administration buoy wave data measured at 5 points along the actual vessel's route was used to specify the characteristic seasonal wave environments. Statistical information was developed on the premise of seasonal fatigue loading and 20 year lifetime extreme values. The extreme values were obtained by adding the maximum dynamic stresses to the still water bending and hydrostatic pressure (internal and external, where applicable). The extreme stress calculated in the bottom shell was in the laden condition and was 207 N/mm² (30 ksi). It would be desirable to verify this value experimentally, also. Table II shows the dynamic stress range histogram developed using this approach for the bottom shell on the subject vessels operating in the TAPS service as part of this study. Use of the stress ranges is described in the next section on fatigue crack propagation.

F) Fatigue Crack Propagation in Bottom Shell Plates

As discussed in the section on inspection capability, there is a strong likelihood of either 2- or 3-in. long surface cracks being present after any given structural inspection. That is, because there are fatigue sensitive details that have been subjected to fairly severe fatigue loading throughout the life of these vessels, cracks continue to initiate from these details. These cracks are difficult to detect when they are small, but as they grow they can be found and repaired. However, cracks smaller than either 2- or 3-in. in length, depending on type of inspection, may not be detected. Thus it is prudent, on the basis of information provided by Coast Guard inspectors, to assume that either 2-in. or 3-in. long surface cracks (depending on type of inspection) may be present after a structural inspection.

An unknown factor is the relative shape of cracks with a surface length of either two or three inches. Although the bottom shell is loaded primarily in tension, there are pressure stresses as well as differences in weld contours that may affect the shape of an unknown crack. Analysis of actual cracks found in the plating samples shows that the relative crack depth (*a*) to surface length (*2c*) ratio, *a/2c*, the crack aspect ratio, can vary from about 0.15 to about 0.35. Figure 1 shows the two initial surface crack lengths of 2- and 3-in. for an assumed *a/2c* ratio of 0.25, which was chosen to model typical crack growth behavior. This assumption appears to be reasonable on the basis of observations of actual fracture surfaces. Studies of ratios ranging from 0.15 to 0.35 indicate that the shape of a 2- or 3-inch long surface crack does not have a significant effect on the fatigue propagation life for the 3/4 in. thick bottom shell plates in these tankers. After the crack grows through the 0.75-in. thick wall, it becomes a through-thickness crack and grows to the critical crack size, $2a_{CR}$, as shown in Fig. 2. Note that for surface cracks, Fig. 1, “*a*” is the dimension through the plate. For through-thickness cracks, Fig. 2, “*a*” is one-half the total crack length. This is common fracture mechanics terminology (6,11).

To estimate the time that it would take either a 2-in. or 3-in. surface crack to grow to critical size, the crack shown in Fig. 1 was subjected to the Δ_{RMS} values presented in Table II and reduced by the reduction factor (RF_{SS}) as described earlier. The stress range histograms shown in Table II were computed using the formulation by Ochi (9,10) and the buoy measured wave data available from NOAA. These histograms show representative stress ranges and numbers of cycles for four seasons in both the fully loaded and normal ballast condition. Δ_{RMS} values for each condition were calculated as follows:

$$\Delta_{RMS} = \sqrt{\frac{\sum \Delta_i^2}{n}}$$

These Δ_{RMS} values were used to represent the variable loading as described by Barsom and Rolfe (11). Individual Δ_{RMS} values are shown at the bottom of each of the eight conditions in Table II. Because the differences in fully loaded and normal ballast conditions were so small, these two conditions were averaged and thus only the four seasonal loading conditions were used in the fatigue analysis.

Based on the information presented in Table II, it was assumed that a representative oil tanker experiences the following four fatigue loading conditions during a typical year:

Winter: $\Delta_{RMS} = \frac{42.01 + 40.54}{2} = 41.28 \text{ MPa} \text{ --} 5.98 \text{ ksi}$
for $N = 251,616 + 258,808 + 510,424$ cycles Reduced Loading $0.7(5.98) = 4.19 \text{ ksi}$

Spring: $\Delta_{RMS} = \frac{37.11 + 36.51}{2} = 36.81 \text{ MPa} \text{ --} 5.34 \text{ ksi}$
for $N = 265,476 + 271,916 = 537,392$ cycles Reduced Loading $0.7(5.34) = 3.74 \text{ ksi}$

Summer: $\Delta_{RMS} = \frac{26.00 + 25.92}{2} = 26.00 + 25.92 = 25.96 \text{ MPa} \text{ --} 3.76 \text{ ksi}$
for $N = 286,221 + 292,672 = 578,893$ cycles Reduced Loading $0.7(3.76) = 2.64 \text{ ksi}$

Fall: $\Delta_{RMS} = \frac{42.20 + 41.62}{2} = 41.91 \text{ MPa} \text{ --} 6.08 \text{ ksi}$
for $N = 267,440 + 273,927 = 541,367$ cycles Reduced Loading $0.7(6.08) = 4.25 \text{ ksi}$

The crack growth behavior of ship steels can be represented by the following expression (11):

$$\frac{da}{dn} = 3.6 \times 10^{-10} (\Delta K_{RMS})^{3.0}$$

Accordingly, the number of cycles, ΔN , that it takes to grow a crack an amount, Δa , is (11):

$$\Delta N = \frac{\Delta a}{3.6 \times 10^{-10} (\Delta K_{RMS})^{3.0}}$$

For a surface crack of length $2c$ and depth a :

$$\Delta K_{RMS} = 1.12 \Delta_{RMS} \sqrt{a/Q} \times M_K$$

where $Q = f(a/2c)$

M_K = back-surface magnification factor

For the through-thickness crack:

$$\Delta K_{RMS} = \Delta_{RMS} \sqrt{a}$$

Fig. 3 shows the calculated size of either a 2-inch long or 3-inch long surface crack versus loading time in months. As a crack grows, it changes from a surface crack (Fig. 1) to a through-thickness crack (Fig. 2). Fig. 3 shows that for the assumptions made earlier (stress ranges, toughness levels, maximum stress levels), the critical crack size, $2a_{CR}$ is about 15-in. and it takes about 60 months to grow a surface crack of 2-inch length to a through-thickness crack of 15 in., depending on $a/2c$ ratio.

Fig. 3 also shows the calculated size of the 3-in. long surface crack as a function of loading time. The behavior is similar to that of the 2-in. surface crack but that, as expected, the time to reach a crack size of 15-in. is less, namely about 48 months. Also, for a surface crack length of 3-in., any $a/2c$ ratio greater than 0.25 is already through the 0.75 in. bottom shell plate and thus any effect of $a/2c$ ratio is smaller than for the 2-in. surface crack. Details of the fatigue crack growth procedure are presented in Reference 11.

The calculated lives shown in Fig. 3 are fairly short and indicate the need for periodic inspection. These results also demonstrate that improved quality of inspection, i.e., an inspection procedure that will find 2-in. surface cracks reliably rather than 3-in long surface cracks, can lead to increased fatigue lives.

G) Recommendations Specific to the Class of Tankers Studied

Because the ships studied as part of this study already are in service, very little if anything can be done to change the materials, design, or actual sea states, although the vessels could be restricted to limited service throughout the year. However, inspection and repair procedures can be changed and clearly could have a significant impact on the safe life of these tankers. For these particular vessels, it is recommended that thorough inspection procedures be followed during ship yard inspections so that the maximum unrepaired bottom shell surface crack sizes are limited to either 2-inches. or 3-inches in length, depending upon type of inspection. If the quality of inspection is such that the maximum surface crack length is less than 2-inches, then an inspection period of two years appears to be reasonable. If the quality of inspection is such that the maximum surface length which can be detected is less than 3-inches, than an inspection period of one year appears to be reasonable.

Both of the above recommendations for the subject tankers depend on the beneficial effects of the longitudinal stiffener details that reduce the stress intensity factor, K_I . Accordingly, any cracking in the longitudinal stiffeners should be repaired during every inspection.

FUTURE RESEARCH

Several assumptions have been made as a part of this study and should be evaluated. Research studies should include the following:

- 1) Experimental verification of calculated fatigue stress ranges and maximum stress levels for tankers subjected to TAPS trade.
- 2) Analytical and experimental studies of reduction factors for cracks beneath single and multiple stiffeners.
- 3) Experimental and analytical studies of fatigue crack growth behavior of cracks beneath single and multiple stiffeners.
- 4) Studies of actual inspection procedures to verify probability of detection (POD) curves for various ship details.
- 5) Experimental studies of large structural details with cracks to verify predictions of critical crack length.

Some of these areas already are being studied as part of the Fleet of the Future Program (FFP). Expansion of that program to include the above studies would seem to be very desirable research areas.

SUMMARY AND RECOMMENDATIONS

The objective of this study was to present a general fracture mechanics methodology that can be used to assess the structural reliability of critical area details in oil tankers experiencing cracking. A methodology that is primarily deterministic has been developed and used to estimate the behavior of cracks in bottom shell plates. Inspection recommendations are based on conservative but reasonable assumptions. For the example presented, the predicted fatigue lives as well as a reasonable minimum critical crack length are consistent with service experience to date. That is, relatively large bottom-shell fatigue cracks have been observed in service but no complete failures have occurred. Using this methodology, similar analysis would be made on other classes of tankers, or other types of vessels.

Estimation of critical crack lengths and fatigue propagation lives of cracks in ships depends on many factors. Thus each class of ships as well as each type of detail must be evaluated individually. This paper describes a fracture mechanics methodology that can be used to estimate the critical crack length and fatigue life of bottom shell cracks in tankers. The example deals specifically with the case of one structural detail in one class of tankers subjected to TAPS service and the results cannot be generalized to other details, ships or loadings. However, the methodology can be used in other cases provided that the specific loadings, material toughness levels, inspection capabilities, and initial crack sizes are established for these other cases.

REFERENCES

1. Report on the Trans-Alaska Pipeline Service (TAPS) Tanker Structural Failure Study, Office of Marine Safety, Security and Environmental Protection, United States Coast Guard, June 25, 1990.
2. Guide for the Fatigue Strength Assessment of Tankers₁ American Bureau of Shipping & Affiliated Companies, June 1992.
3. Sielski, R. A., "Fracture Mechanics of Ship Structures," Naval Engineers Journal, May 1992, pp 36-45.
4. Trans-Alaska Pipeline Service (TAPS) Tanker Structural Failure Study Follow-up Report, Office of Marine Safety, Security and Environmental Protection, U. S. Coast Guard, May 1991.
5. American Bureau of Shipping, Rules for Building and Classing Steel Vessels, annual publication.
6. Rook, D. P. and Cartwright, D. J., Compendium at Stress Intensity Factors, Crown, Copyright 1976, Printed in England for her Majesty's Stationary Office by the Hillingdon Press, Uxbridge, Midde.
7. Holzman, R. S. and Demsetz, L., "Advancements in Tankship Internal Structural Inspection Techniques," Structural Maintenance for New and -Existing Ships, Joint Industry Research Report, Report No. SMP-5-2, August 1992.
8. "A Guide for Combatting Fatigue," Surveyor, A Quarterly Publication of the American Bureau of Shipping, December 1992, pp 24-31.
9. Ochi, M. K., "On Prediction of Extreme Values," Journal at Ship Research, March 1973, pp 29-37.
10. Ochi, M. K., "Wave Statistics for the Design of Ships and Ocean Structures," Transactions SNAME, Vol. 86, 1978, pp 47-76.
11. Barsom, J. M. and Rolfe, S. T., Fracture and Fatigue Control in Structures: Applications off Fracture Mechanics, Second Edition, Copyright 1987, Prentice-Hall, Inc., Englewood Cliff, New Jersey.
12. S. T. Rolfe, W. A. Sorem, and R. H. Dodds, "An Analytical Comparison of Short Crack and Deep Crack CTOD Fracture Specimens of an A-36 Steel,"; "The Effects of Crack Depth on Elastic-Plastic CTOD Fracture Toughness," and "A Comparison of the J-Integral and CTOD Parameters for Short Crack Specimen Testing," Welding Research Council Bulletin No. 351, February 1990. "Effects of Crack Depth . . .," also published by International Journal at Fracture, No.47, 1991, pp 105- 126. "A Comparison of the J-Integral. .," also published by American Society for Testing and Materials, ASTM STP 1114, pp 19-41, 1991.

Table I -- CTOD Test Results from Bottom Shell Plates

CTOD Test Results				
mils (0.001 in.)				
<u>Temp., °F</u>	<u>Plate PC7</u>	<u>Plate PC8-A</u>	<u>PC8-HAZ</u>	<u>PC8-Weld</u>
-76		6.8		
-40		20.4		
-4		31.9		
14	2.4			
32	1.9	29.7	7.0	5.4
32	2.8	28.4	29.3	9.9
32	<u>2.4</u>	<u>28.9</u>	<u>9.5</u>	<u>10.4</u>
Avg	2.4	29.0	15.3	8.6
78	8.2	30.2		
78	8.7	33.6		
78	<u>6.3</u>	<u>27.6</u>		
Avg	7.7	30.5		
104	12.8			
140	35.1			

Range of (N/mm ²)	Range of (N/mm ²)	Average Δσ (N/mm ²)	FULL LOAD				NORMAL BALLAST				ANNUAL TOTAL
			Spring (M,A,M)	Summer (J,J,A)	Fall (S,O,N)	Winter (D,J,F)	Spring (M,A,M)	Summer (J,J,A)	Fall (S,O,N)	Winter (D,J,F)	
0	10	5	28886	84717	29781	24563	31225	87494	32243	27171	346080
10	20	15	51032	78971	41011	39814	53548	81520	43165	43309	432370
20	30	25	57664	51971	49465	48155	59495	53013	51162	51100	422025
30	40	35	49488	35064	46511	45123	50117	34751	47424	46539	355017
40	50	45	34963	20102	36928	35396	34933	19971	37079	35491	254863
50	60	55	21342	9579	26038	24452	21170	9738	25807	23910	162036
60	70	65	11654	3892	16769	15373	11496	4084	16497	14676	94441
70	80	75	5824	1367	10002	8974	5681	1479	9823	8332	51482
80	90	85	2699	417	5560	4922	2570	462	5468	4401	26499
90	100	95	1169	111	2887	2553	1066	125	2842	2169	12922
100	100	105	475	25	1403	1257	407	29	1377	999	5972
110	120	115	182	5	639	589	143	5	1377	432	2617
120	130	125	66		273	263	46	1	261	176	1086
130	140	135	23		110	112	14		102	67	428
140	150	145	7		42	45	4		37	24	159
150	160	155	2		15	17	1		13	8	56
160	170	165			5	6			4	3	18
170	180	175			1	2			1	1	5
180	190	185									0
		SUM	265476	286221	267440	251616	271916	292672	273927	258808	2168076
		Δσ _{RMS}	37.11	26.00	42.20	42.01	36.51	25.92	41.62	40.54	36.81

Table II -- Wave Loadings and Numbers of Cycles and Values of Δσ_{RMS} for Center of Center Tank, Bottom Shell Plating

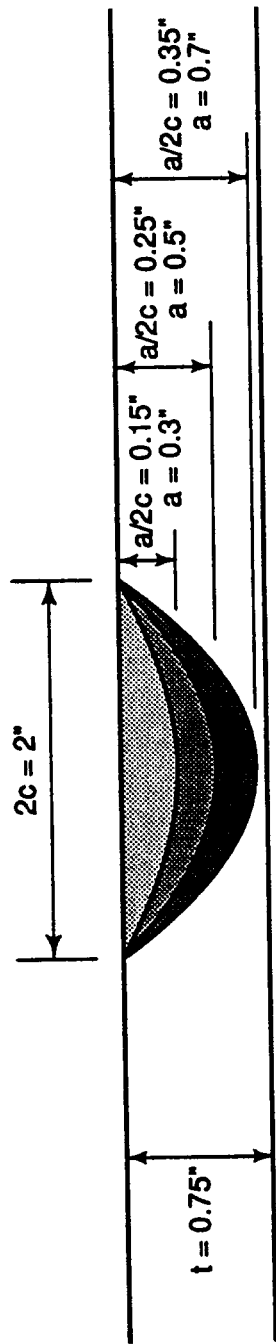

a) 2-Inch Long Surface Crack.

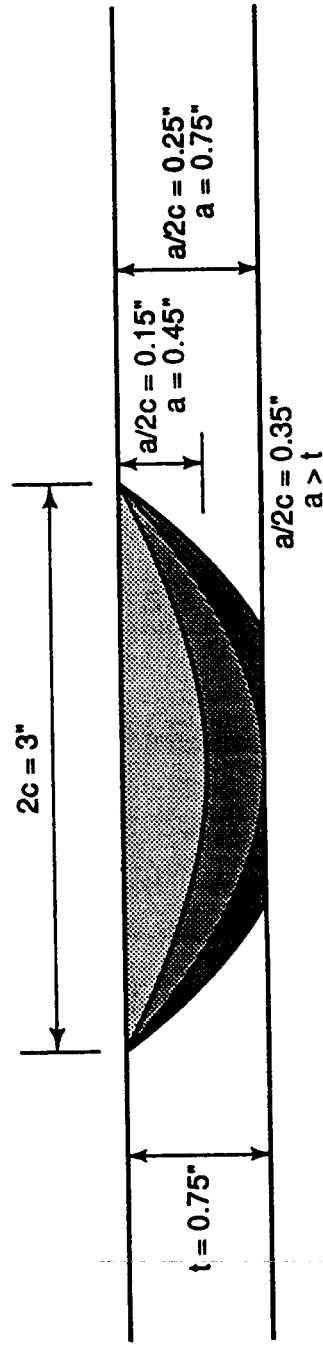

b) 3-Inch Long Surface Crack

Figure 1. Surface Crack Model for $a/2c = 0.15$, 0.25 , or 0.35 and $2c = 2$ -Inch or 3-Inch.

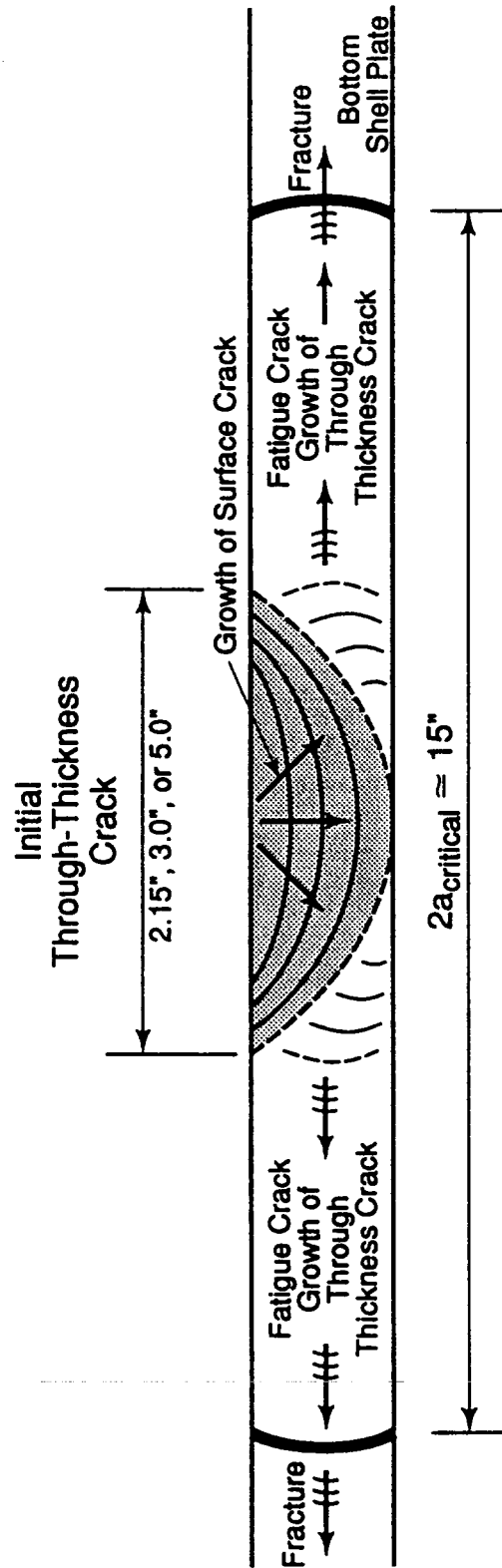

Figure 2. Through Thickness Crack Growth Model. Crack Grows from \sim to $2a_{cr} = 15"$ at $2a_{cr}$ – Rapid Fracture Occurs.

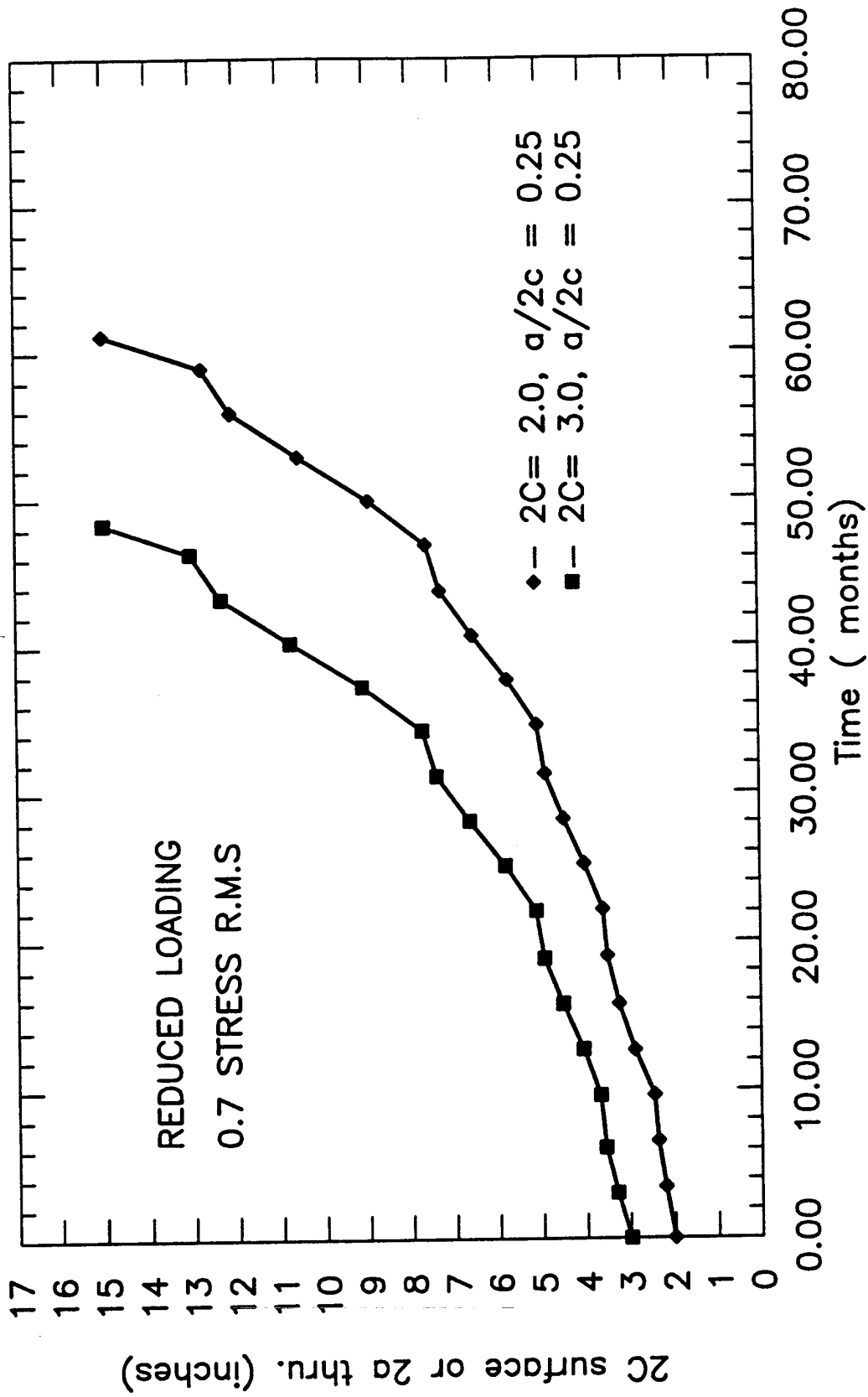

FIG (3)– The effect of 2C value on the crack growth time
Using the reduced stress (0.7 stress R.M.S)